

# CS 120

This compressor model....., s/n..... was shipped with the following factory installed features:

- |  |      |  |
|--|------|--|
| <input type="checkbox"/> .....             | Volt | <input type="checkbox"/> Cabinet heaters           |
| <input type="checkbox"/> Wye-Delta Start   |      | <input type="checkbox"/> 115 V receptacle          |
| <input type="checkbox"/> D.O.L. Start      |      | <input type="checkbox"/> Outdoor modification      |
| <input type="checkbox"/> .....             | psig | <input type="checkbox"/> Rainhoods                 |
| <input type="checkbox"/> .....             |      | <input type="checkbox"/> Nema 4 door               |
| <input type="checkbox"/> .....             |      | <input type="checkbox"/> Switchable Modulation     |
| <input type="checkbox"/> Wiring Schematic: |      | <input type="checkbox"/> Synthetic lubricant ..... |
| <input type="checkbox"/> .....             |      | <input type="checkbox"/> Food Grade lubricant..... |

## KAESER COMPRESSORS, Inc.

4950 Quality Drive • P.O. Box 946 • Fredericksburg, Virginia 22 404  
Tel. (703) 898-5500 • Fax. (703) 898-5520

## I M P O R T A N T

Read entire service manual before operating unit or performing any maintenance.

Always shut off power to unit at main disconnect switch before attempting any maintenance. All system pressure should be discharged unless manual instructs otherwise.

Use only "Kaeser Compressors" approved replacement parts.

Compressed air from any oil lubricated compressor is not suitable for use in any breathing apparatus or food related process.

## A T T E N T I O N

Kaeser Compressors declines responsibility for any modifications made to any Kaeser compressor other than those made at the Kaeser factory or those made with prior written permission from Kaeser Compressors.

**SAFETY PRECAUTIONS**

Every Screw Compressor is operated and thoroughly tested at the factory before shipment to make sure the compressors delivers its rated capacity and is in good working order. However, all the care given at the factory will not prevent possible damage during transit. We recommend the unit be carefully inspected for evidence of possible damage in shipment. During the first few hours of operation, the machine should be watched for any possible malfunction.

**Comply with the following before start-up**

- Remove all packing, tools and debris from in and around unit before operating.
- Do not operate in the presence of toxic or flammable vapor.
- Work on current-carrying parts may only be carried out by an appropriate personnel.
- Do not operate the compressor at a voltage other than the one specified on the compressor nameplate.
- Do not operate the compressor at pressures exceeding the maximum pressures indicated on nameplate.
- Install the compressor in an area where the air inlet temperature is at least 40° F but no higher than 100° F.
- If an air outlet duct is provided, it should be at least the size of the cooler surface and its length should not exceed 13 ft.
- Install the compressor to maintain a distance of 3 ft. between the cooling air inlet of the unit and the wall.
- Do not shut off the compressor operating with load at the main disconnect switch. Push stop button (7, Figure 4).
- Check for proper direction of rotation.  
DO NOT OPERATE UNIT IF ROTATION IS INCORRECT.
- Make sure the shutoff valve (4, Figure 22) is closed.
- Make sure the shutoff valve (3, Figure 23) at the discharge line is open.
- Shut off the unit, tighten up all the screws in the control box (repeat this after 50 operations hours).

**Attention:** This work man only be done while the unit is disconnected from the electrical supply.

- To guarantee the cooling air circulation in the compressor unit, be sure the maintenance doors tightly closed during operation.

**Attention:** Operating the compressot with open maintenance doors is prohibited because the belt drive and electrical components may cause personal injury.

**FAILURE TO HEED THIS OR ANY OTHER WARNING MAY RESULT IN AN ACCIDENT CAUSING PERSONAL INJURY OR PROPERTY DAMAGE.**

**Attention:**

This units (not available for BS 44) have been fitted with a run-in oil filter cartridge. Replace the cartridge after approx. 200 operation hours. See section 6.3

## Table of Contents

	Page
1. Dimensions and specifications	4
2. Description of the Sigma screw compressor	4
3. Design and function of the unit	5/6
4. Installation	7
4.1 Ventilation of the air-cooled units	7
4.2 Air discharge connection	8
4.3 Electrical connection	8
4.4 Overload relay adjustment	9
5. Preparation for initial start-up	10
5.1 Start-up after oil change and/or long standstill	10
5.2 Checking the direction of rotation	11
5.3 Instrument panel	11
5.4 Safety system KAESER CONTROL	12
5.5 Idle time adjustment	13
5.6 Pressure switch adjustment	13
5.7 Control system	14
5.7.1 DUAL-Control (standard)	14
5.7.2 Quadro-Control (optional)	15
6. Maintenance schedule	16
6.1 Air inlet filter	16
6.2 Filter mat	17
6.3 Oil filter	17
6.4 Oil separator	18
6.4.1 Filter replacement	18
6.4.2 Mounting of elastic pipe connection	19
6.5 Compressor oil specification	20
6.5.1 Mineral oils	20
6.5.2 Synthetic oils	21
6.6 Adding oil	22
6.7 Oil change	23
6.8 Temperature gauge with high temperature switch	24
6.9 Motor lubrication	24
6.10 V-belt tension	25
6.10.1 V-belt changing	25
6.11 Cleaning the cooler	26
6.12 Checking the safety valve in the oil separator tank	27
6.13 Maintenance parts list	28
6.14 Recommended maintenance schedule	29
6.15 Maintenance check list	30
7. Wiring diagram	31/1-4
8. Dimensional drawing	32
9. Transport instructions	33
10. Trouble shooting	34
10.1 Airend temperature is too high (greater than 155-180°F)	34/35
10.2 Motor overload relay switches the unit off	36/37
10.3 Compressor is running but produces no pressure	38
10.4 Oil flows out of air filter	39
10.5 Full-load/Idle sequence occurs too frequently	39
10.6 Safety-valve blows off	40
10.7 Oil in the unit enclosure	41
10.8 Excessive oil consumption	42
11. Valve Service Supplement	43
11.1 Check valve	43
11.2 Combination (thermostatic) valve	44/45
11.3 Control valve	46
11.4 Inlet valve	47
11.5 Minimum pressure check valve	48
11.6 Oil stop valve	49
11.7 Vent valve (Discharge valve)	50

**1. DIMENSIONS AND SPECIFICATIONS**

Model	Maximum pressure psig	Free air delivery unit cfm	Motor		
			kW	hp	rpm
BS 44	110	170	30	40	3600
	145	155			
	190	135			
BS 50	110	195	30	40	1800
	145	165			
	190	145			
BS 60	110	240	37	50	1800
	145	205			
	190	178			
CS 75	110	282	45	60	1800
	145	252			
	190	215			
CS 90	110	360	55	75	1800
	145	309			
	190	253			
CS 120	110	458	75	100	1800
	145	390			
	190	340			

**2. DESCRIPTION OF THE SIGMA SCREW COMPRESSOR**

The main components of the Sigma Screw Compressor are a housing and two rotors. The compressor operates according to the rotary piston principle and is driven by an electro-motor through V-belts.

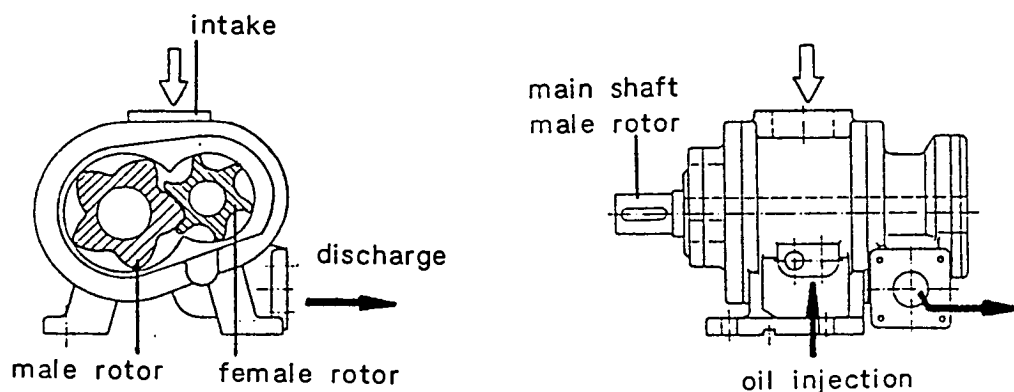

Figure 1

There are two rotors with antifriction bearings in the housing: a male rotor with 5 lobes driven by the motor and a female rotor with 6 voids. While the rotors are turning, air is drawn in through the inlet port at the upper side of the housing and the trapped air is compressed at the lower side.

The oil injected into the housing at the lower side picks up the heat resulting from the compression process, prevents the rotors from contacting each other and lubricates the antifriction bearings at the same time.

As there are no unbalanced forces, inlet or outlet valves, smooth running of the unit is ensured.

3. CONSTRUCTION AND FUNCTION OF SCREW COMPRESSOR MODEL BS/CS

T 7439

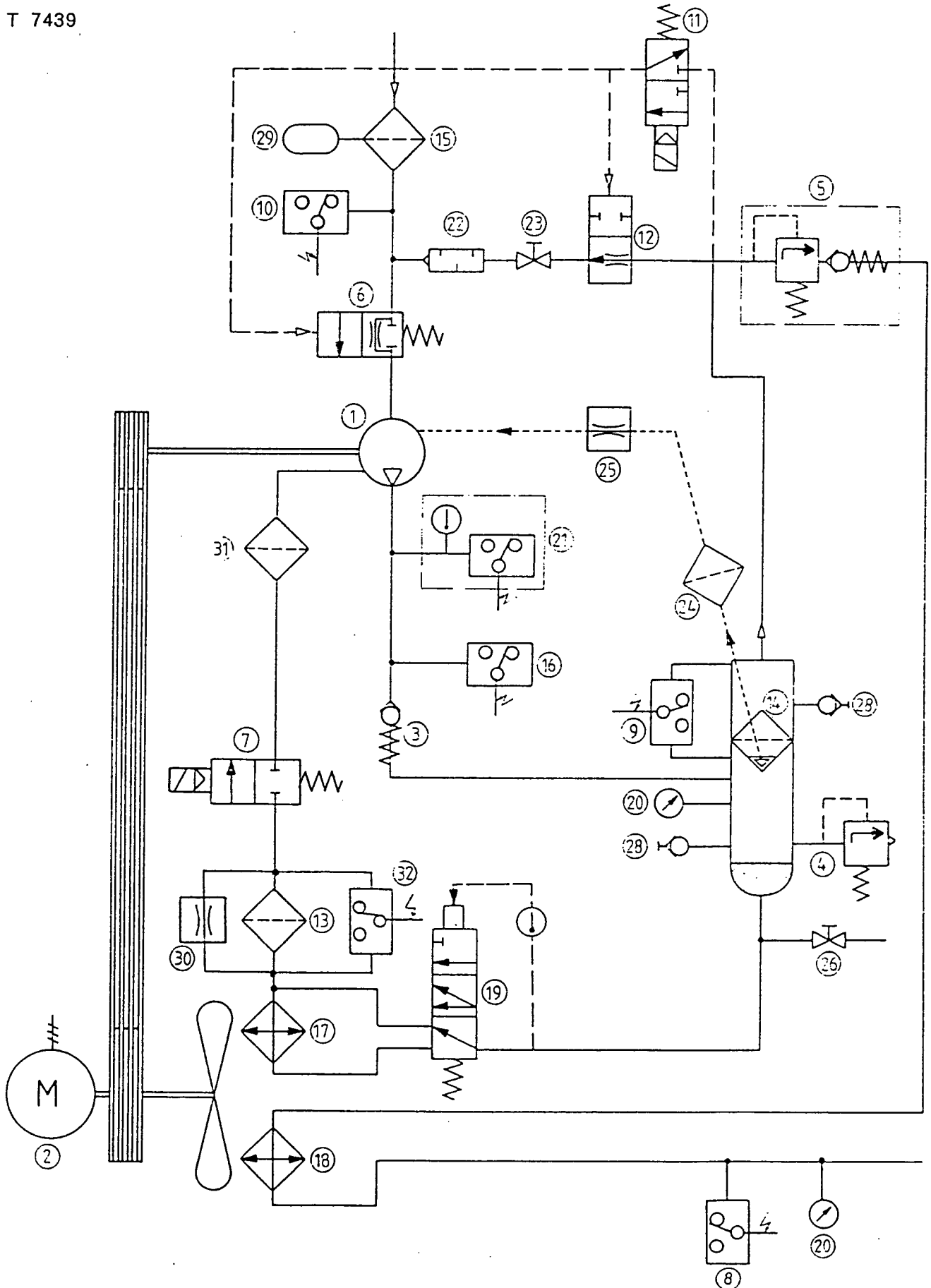

BS/CS 4/03.86

**Construction and function of screw compressor Model BS/CS**

T 7439

- 1 Compressor
- 2 Driving motor
- 3 Check valve
- 4 Safety valve
- 5 Minimum pressure check valve (min. pressure approx. 65 psig)
- 6 Inlet valve
- 7 Oil stop valve
- 8 Pressure switch / Full load - idling ( $\Delta p$  min 10 psi)
- 9 Differential pressure switch / Oil separator cartridge  
 $\Delta p = 14,5$  psi (indicative)
- 10 Differential pressure switch / Air filter  
 $\Delta p = 0,8$  psi (indicative)
- 11 Control valve
- 12 Vent valve
- 13 Oil filter (by-flow filter\*) 10  $\mu$ m
- 14 Oil separating cartridge
- 15 Air filter 4  $\mu$ m  
(not required, if bag-type filter is used)
- 16 Pressure switch (faulty direction of rotation; switching point 5/15 psig)
- 17 Oil cooler (air-cooled)
- 18 Air after cooler (air-cooled)
- 19 Oil temperature controller (opening temp. approx 160° F)
- 20 Pressure gauge
- 21 Contact thermometer + indication (switching point 230° F)
- 22 Silencer
- 23 Ball cock
- 24 Dirt-trap
- 25 Nozzel (dia. 3/64")
- 26 Oil drain cock
- 28 Hose coupling
- 29 Dust sump
- 30\* Main flow nozzle
- 31\* Strainer 350  $\mu$ m
- 32 Differential pressure switch / Oil filter  $\Delta p = 18$  psi (indicative)

\*not available for BS 44

**4. INSTALLATION**

**4.1 Ventilation for air-cooled units**

Installation of the screw compressor should take place according to the following schedule. For easy access and service, respect the minimum distances indicated below.

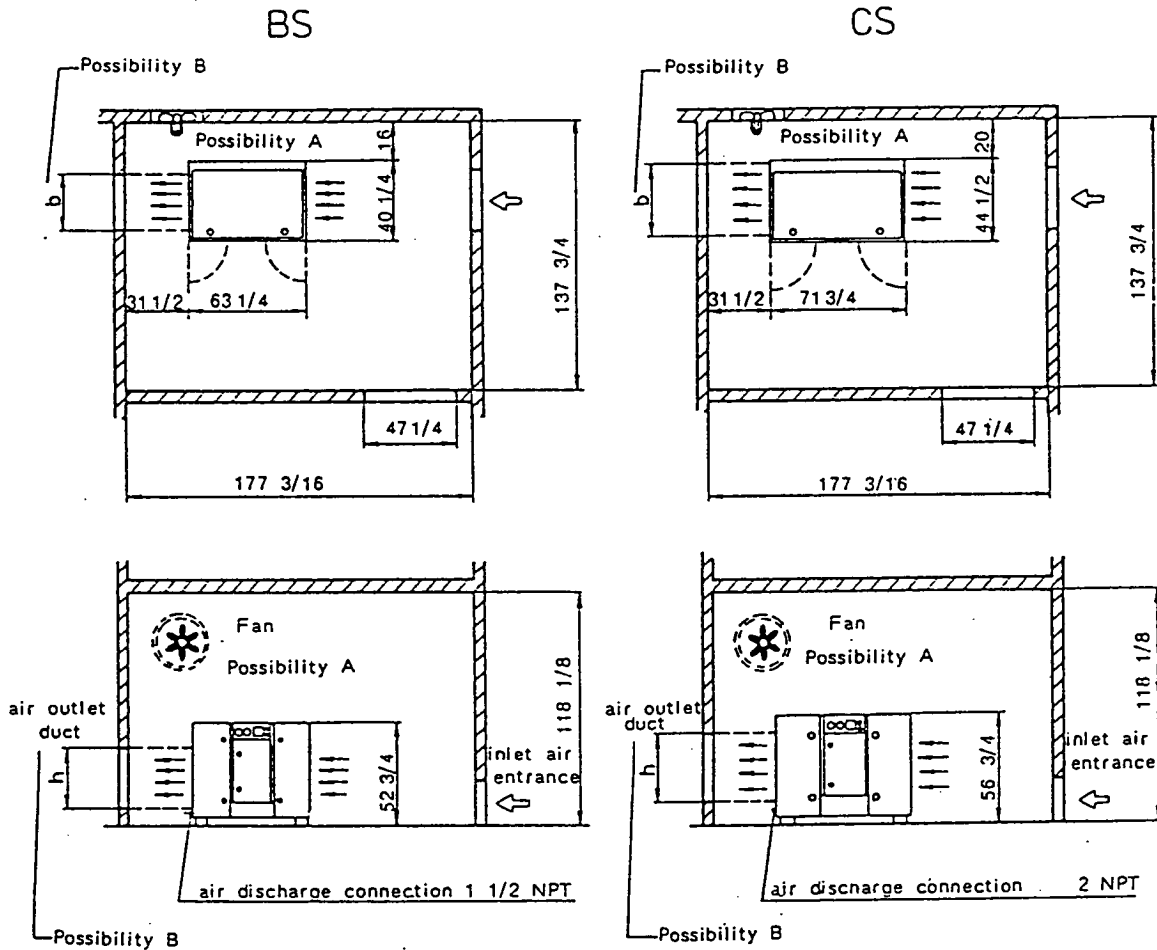

Figure 3

The compressor room should provide adequate ventilation.

Model	Possibility A Ventilation: fan cfm at a static pressure of 0.4 inches WC	Possibility B Exhaust air is used for heating  w x h inches	Required size at air inlet entrance for A and B  sq.ft.
BS 44	5000	27 x 30	6.5
BS 50	5000	27 x 30	6.5
BS 60	6200	27 x 30	8
CS 75	7700	36 x 34	10
CS 90	9500	36 x 34	13
CS 120	14000	38 x 40	17.5

BS/CS 4/02.87

On water cooled units values indicated on the above chart for inlet air duct and forced ventilation are reduced approx. 25 %. Possibility B does not apply.



**Possibility A:**

Air delivery of the exhaust fan must be adequate for the size of the unit (see chart on page 7).

**Possibility B:**

Warm exhaust air is forced through a duct into the room to be heated. Consult KAESER COMPRESSORS for maximum allowable pressure drop in exhaust ducts.

To ensure trouble-free operation of the unit, cooling air temperature should not drop below 40°F and not exceed 100°F.

**4.2 Air discharge connection**

The unit is piped ready for operation. It must be connected to the air line with a flexible connecting hose. A check valve is not required in the discharge line as one is built into the unit.

**4.3 Electrical connection**

The unit is wired ready for operation and it needs only be connected to the supply line. Pull the cable with conductors L1, L2, L3 and earth E through the openings of the base frame into the controller and connect them to the terminals marked L1, L2, L3 and earth E. The main disconnect switch and main fuses must be supplied by the purchaser. This main disconnect switch must have a minimum switching capacity which is 1.1 times the indicated rated power of motor.

The required fuses and cross sections of cables are shown in the following chart.

Model	Motor		WYE-Delta start 230 V, 3-phase, 60 cycles		WYE-Delta start 460 V, 3-phase, 60 cycles	
	kW	hp	Fuse dual element Amps	Conductor wire size AWG	Fuse dual element Amps	Conductor wire size AWG
BS 44	30	40	100	1	60	6
BS 50	30	40	100	1	60	6
BS 60	37	50	150	1/0	80	4
CS 75	45	60	200	3/0	100	3
CS 90	55	75	225	4/0	125	2
CS 120	75	100	300	350 MCM	150	2/0

BS/CS 4/03.86

#### 4.4 Overload relay adjustment

WYE-Delta start 460 V, windings WYE-Delta switching

Only the phase current of a winding is led through the overload relay. This phase current is only 0.58 time the motor rated current  $I_N$ , accordingly the relay has to be adjusted for  $I_N \times 0.58$ .

Adjustment:

The overload relay should be adjusted approx. 10 % higher than phase current of a winding. This will prevent it from acting at voltage fluctuations.

SHUT OFF POWER TO UNIT AT MAIN  
DISCONNECT SWITCH BEFORE ATTEMPTING  
ANY ADJUSTMENTS TO COMPRESSOR.

**5. PREPARATION FOR INITIAL START-UP**

see 'SAFETY PRECAUTIONS' on Page 2

**5.1 Start-up after oil change and/or long standstill**

The following procedure must be observed when starting the unit after an oil change and/or a standstill period of three (3) months and over.

**To add oil in the airend intake port:**

Before starting the unit, pour oil in the airend intake port, in quantities below recommended and rotate the airend by hand.

Model	Quantity
BS 44	1 pint
BS 50/60	1 quart
CS	1 quart

**Important:**

Use the same brand and quality of oil as the one being used to operate the compressor unit only (refer to the specs label on the oil separator tank), or drain oil from the oil separator tank and use for that purpose.

**Caution:**

Discharge pressure in unit before draining any oil.

To add oil, unscrew the air inlet connection at the inlet port, open the butterfly valve by hand and pour recommended amount oil into the airend. Screw air inlet connection back on.

**To increase wye time respectively time of released start, at start-up:**

For start-up, increase wye time relay respectively released start time relay to 20 seconds to prevent compression of inlet air during start-up. Stop unit by pushing stop button JUST BEFORE REACHING THE 20 SECOND LIMIT.

Once this is done, the wye time relay respectively released start time relay must be set back to its normal operating point according to the following chart.

Model	WYE time
BS	9 sec.
CS 75/90	9 sec.
CS 120	12 sec.

These two preventive measures will ensure that the airend is getting sufficient oil when starting up the unit and will provide sufficient time for filling the oil cooler and all oil lines.

**Attention:**

After a standstill of more than 12 months further special procedures are required before the initial start-up. For that consult KAESER COMPRESSORS, INC.

BS/CS 4/02.87

**5.2 Checking the direction of rotation:**

- Push momentarily start and then stop button (parts 6 and 7, Figure 4) and check for proper direction of rotation.
- Arrows on motor and airend housing indicate direction of rotation.
- Should direction of rotation be incorrect, conductors L1 and L2 must be interchanged.

**WARNING**

If the compressor rotation is wrong do not operate the unit.

**5.3 Instrument Panel**

**Compressor start-up**

- Cut in main disconnect switch
- Push start button (6)

**Compressor stop**

- Push stop button (7)
- Shut off main disconnect switch

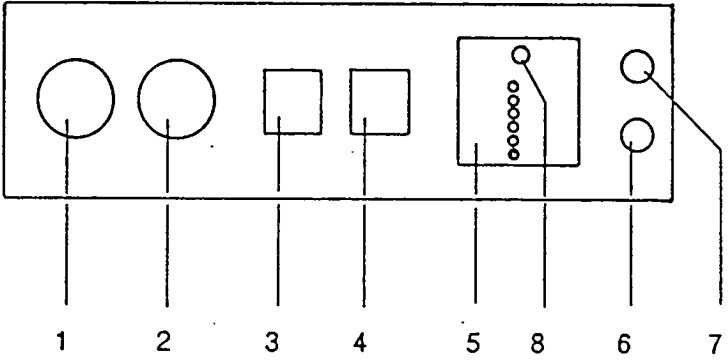

Figure 4

- 1 Outlet pressure of unit
- 2 Temperature gauge
- 3 Hourmeter (service hours)
- 4 Hourmeter (full load hours)
- 5 KAESER CONTROL
- 6 Start button
- 7 Stop button
- 8 Reset button

**Important:**

Do not shut off the compressor operating with load at the main disconnect switch. Use the stop button on the unit first.

**5.4 Safety system: KAESER CONTROL**

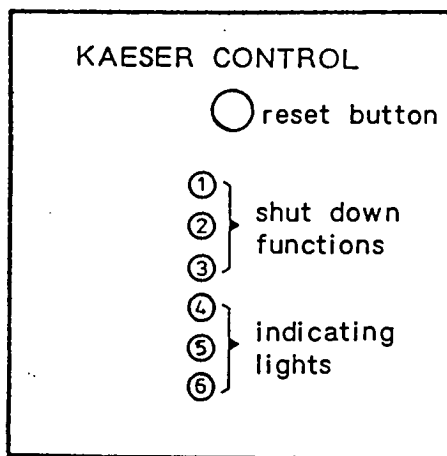

- 1 Overload of compressor motor
- 2 Excessive temperature
- 3 Airend - low pressure
- 4 Oil filter contamination
- 5 Oil separator contamination
- 6 Air inlet filter contamination

Figure 5

In case of malfunction (lights 1, 2 or 3) the compressor is **shut down** by:

- 1 Overload rely of the compressor motor.  
After having eliminated the trouble, push first the contact pin at the overload relay, then the reset button (Figure 5). Now the compressor is ready for operation.
- 2 Thermostatic switch for final compression temperature will shut unit off when temperature reaches 230°F.
- 3 Pressure switch (16, Figure 2) at the air inlet port of the airend will shut down the unit if the V-belts are broken or have slipped.

Maintenance requirements are monitored by indicating lights 4, 5 and 6 with **warning functions only**.

- 4 Differential pressure switch (32, Figure 2) indicates oil filter contamination.
- 5 Differential pressure switch (9, Figure 2) indicates oil separator contamination.
- 6 Vacuum switch (10, Figure 2) indicates air inlet filter contamination.

Watch and check indicating lights 4 and 5 only after unit has been running for a minimum of 5 to 10 minutes from start-up. Warning light 6 will stay on until cartridge is cleaned.

To restart unit, press reset and "ON" buttons.

**Checking the indicating lights:**

For checking the function of the indicating lights, press the reset button. All lights should come on.

**Checking the safety system of the indicating lights with shut-down function:**

To guarantee maximum safety, check the shut-down function of the lights at least every 2000 operating hours:

Switch on the main switch, press the stop button and pull out the pins of the 3 disconnection terminals No. 8, 9 and 18 one after the other.

While doing so, the stop button should go out and the corresponding indicating light come on.

## 5.5 Idle time adjustment

The time delay relay for idling time is located in the control box (time 3-30 minutes). The idling phase should be set in such a way that the maximum permissible cutting in frequency of the motor is not exceeded.

Model	Cutting in frequency (per h)	
	ODP	TEFC
BS 44	15	8
BS 50	30	15
BS 60	15	15

Model	Cutting in frequency (per h)	
	ODP	TEFC
CS 75	15	15
CS 90	15	8
CS 120	8	8

## 5.6 Pressure switch adjustment

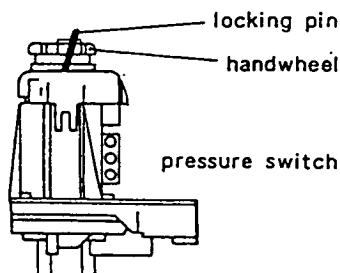
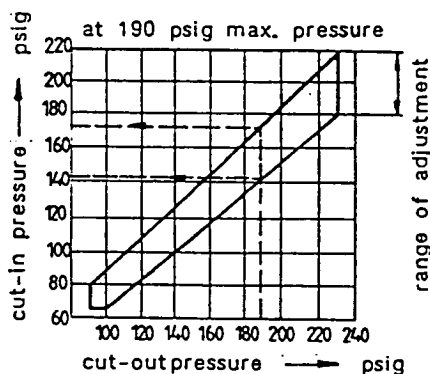
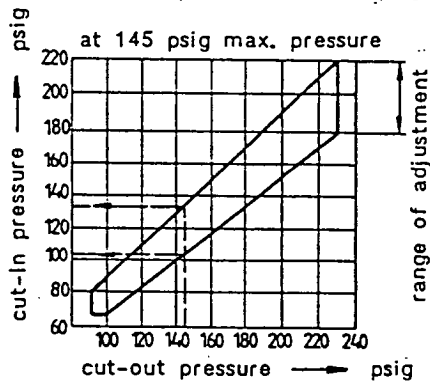
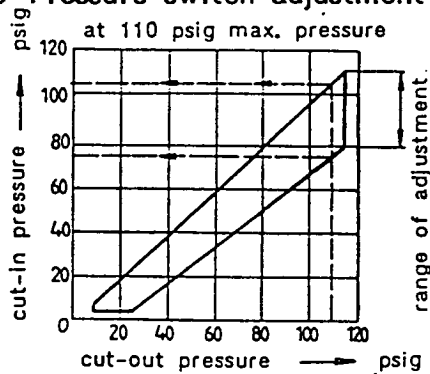

Adjustment of the switch differential at the pressure switch for limiting the switching frequency.

**Maximum frequency of idling operation:  
twice a minute**

By increasing the switch differential between cut-out and cut-in the switching frequency can be reduced to a limited extent. If this is not sufficient a larger air tank is required.

The pressure switch has been pre-set at the factory as follows:

- 110 psig units: 100 to 110 psig ( $\Delta p = 10$  psi)
- 145 psig units: 135 to 145 psig ( $\Delta p = 10$  psi)
- 190 psig units: 180 to 190 psig ( $\Delta p = 10$  psi)

Pressure adjustment can only be carried out at the mounted pressure switch when the compressed air line is under pressure.

**Cut-out pressure:**

For higher pressure: turn handwheel to the right  
for lower pressure: turn handwheel to the left

**Cut-in pressure/switch differential:**

To increase the difference between cut-in and cut-out pressure:

- remove locking pin
- press handwheel so that the cross pin at the top of the handwheel comes out, then turn handwheel to the left
- place in locking pin.

To decrease the difference between cut-in and cut-out pressure:

- remove locking pin
- proceed as indicated above but turn handwheel to the right
- place in locking pin

### Caution

Before removing the pressure switch cover, shut off the compressor (stop button and main disconnect switch). After each read adjustment at pressure switch, place cover on pressure switch before switching on the compressor.

5.7 Control systems

5.7.1 DUAL-Control (standard)

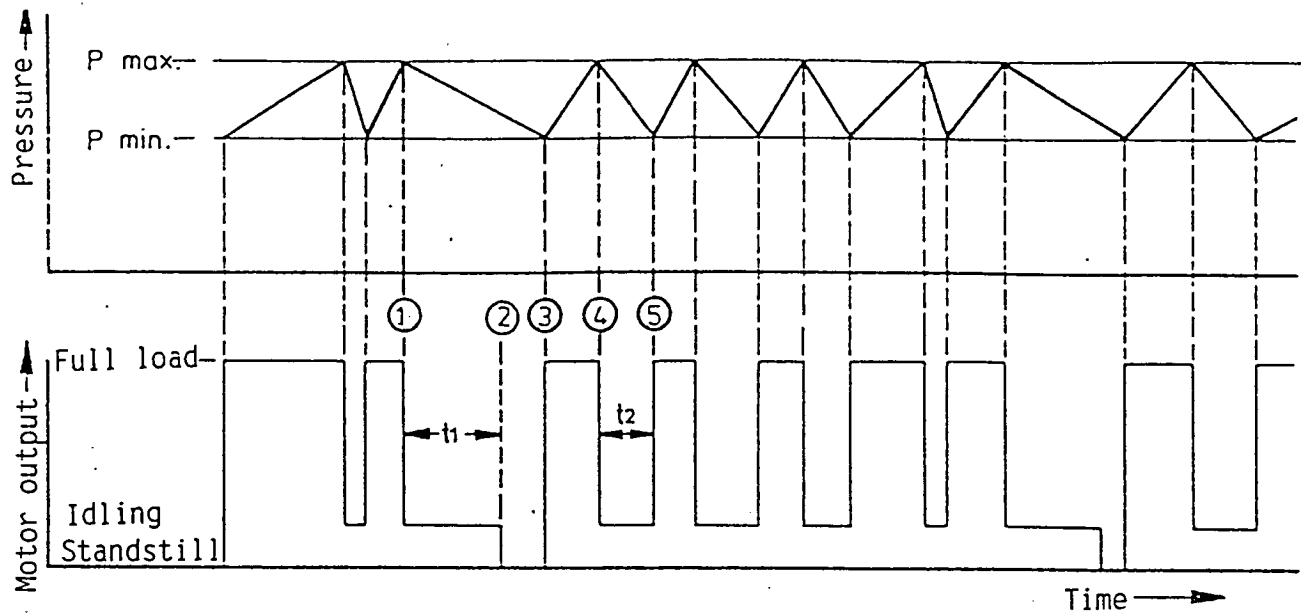

Figure 10

With the DUAL-Control (combined idling/ intermittent operation control system) the compressor operates only at the following two points:

**full load and idling**

The compressor pressure is regulated by a pressure switch within the pressure limits, e.g. between 100 - 110 psig. This results in an extremely low switching differential of only 10 psig between full load and idling.

If the compressor continues to idle longer than for a pre-set adjustable period (1) to (2) e.g.  $t_1 = 6$  min, then the electric motor will be switched off completely at (2).

Upon reaching the lower switching point at  $p_{min}$  (3) e.g. 100 psig, the unit is switched on again automatically. If, however, the pressure drops again to  $p_{min}$  (5) within a shorter period (4) to (5) e.g.  $t_2 = 3$  min, then, automatic switching over to full load will take place.

**5.7.2 QUADRO-Control (optional)**

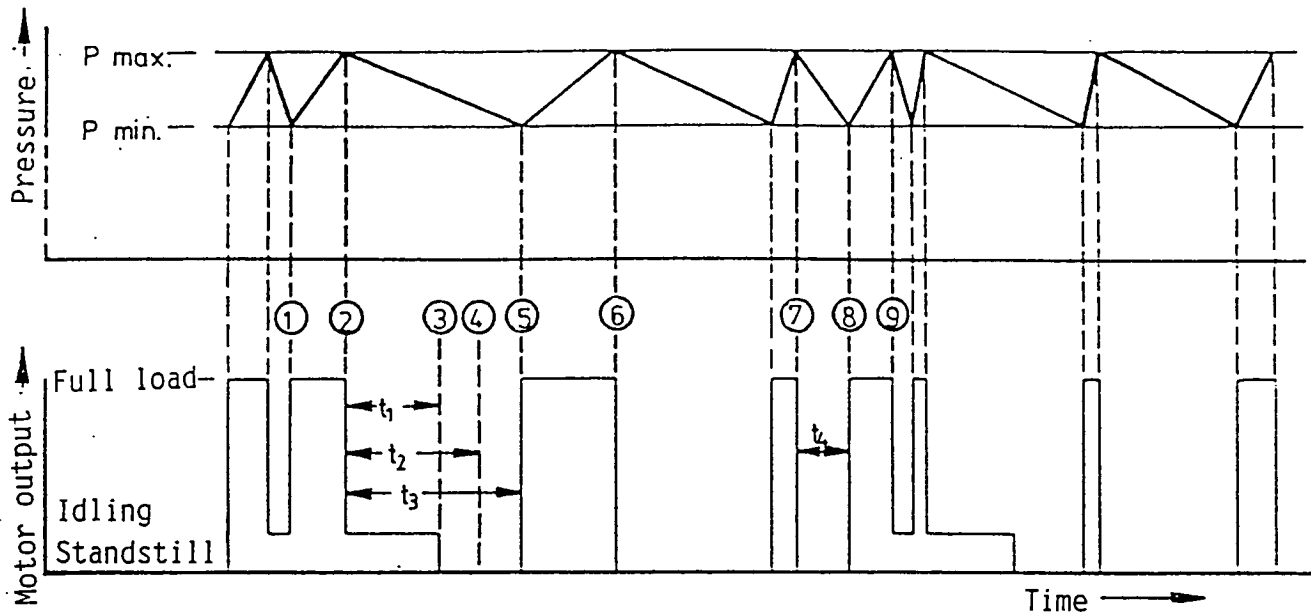

Figure 11

The Quadro-Control provides even greater savings in the case of widely varying air demand.

The following controls and operating modes are possible:

- Upon reaching the lower pressure limit of the pressure switch  $p_{min}$  (1), the control automatically selects **full load**.
- When the upper pressure limit  $p_{max}$  (2) is reached, the control automatically selects **idling**.
- At the end of the pre-set idling period (2) to (3) e.g.  $t_1 = 4$  min, the compressor is switched to **standstill**.
- If the time is dropping from  $p_{max}$  (2) to  $p_{min}$  (5) e.g.  $t_3 = 6$  min is longer than the comparison period (2) to (4) e.g.  $t_2 = 5$  min, the **intermittent operation** mode is selected automatically and the compressor drops to standstill rather than to idle for the subsequent cycle (6). If the time from (7) to (8) is shorter e.g.  $t_4 = 2$  min, the idling mode is selected again for the following cycle (9). This comparison with the fixed time " $t_2$ " is repeated for each pressure drop.

The QUADRO-Control also replaces the commonly used selector switch for idling/intermittent operation in selecting the optimum operating mode automatically.



## 6. MAINTENANCE SCHEDULE

### Always follow maintenance instructions:

- Before performing any maintenance on the unit, push stop button (7, Figure 4) and cut off main disconnect switch to make sure the power is off.
- Before restarting, make sure no one is working on the unit and covering plates are back on, as well all doors are closed
- After switching on main disconnect switch, start unit by pushing start button (6, Figure 4).
- In case of power failure or cutoff at main disconnect switch, restart unit manually by pushing the start button.
- The socket to vent the tank is attached to the hose coupling (4, Figure 22). It is used for maintenance work, such as oil refill, oil and filter change.
- Work on current-carrying parts may only be carried out by an appropriate personnel.

### 6.1 Air inlet filter

Clean the air inlet filter, when the warning light 6 of KAESER CONTROL (Figure 5) comes on.

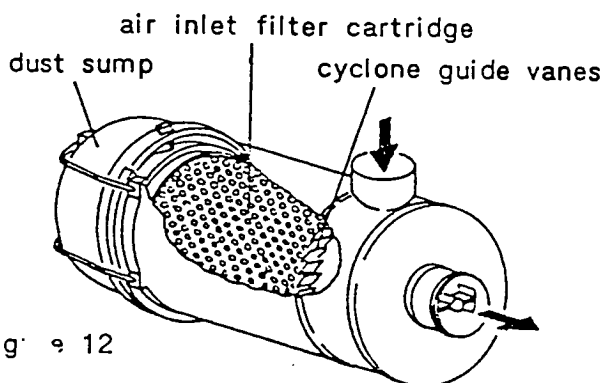

Figure 12

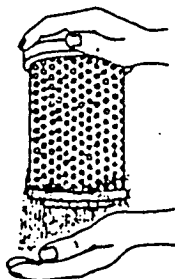

Figure 13

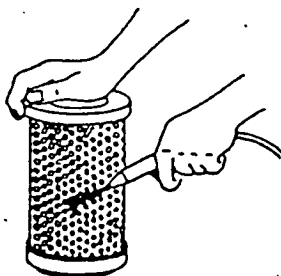

Figure 14

- Shut off the compressor (stop button and main disconnect switch).
  - Opening of the filter housing (Figure 12):
  - Remove and empty dust sump.
- Important:**  
Make sure dust sump is reassembled correctly.
- Cleaning by tapping off the dust (Figure 13):  
Tap the front side of the cartridge against your palm until all the dust has fallen out. Avoid damaging the cartridge. Clean the contact surfaces of the gaskets.
  - Blow clean with compressed air (Figure 14):  
Blow dry compressed air (no higher than 70 psig) slanted against the paper pleats. Then blow clean the inside of the cartridge thoroughly.

**Caution:**

Do not use fluids to clean air filter. Replace cartridge after several cleanings (Max. 5 cleanings) or if cartridge is overly contaminated.

## 6.2 Filter mat

Clean filter mat every 100 to 300 operating hours depending on amount of dust.

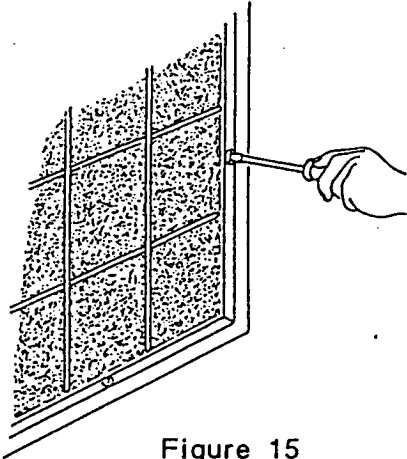

Figure 15

- Shut off the compressor (stop button and main disconnect switch).
- Remove cover frame with a screwdriver. To mount, turn screws 90° (Figure 15).
- Cleaning:  
Rinse the mat in water of approx. 100° with some mild detergent. Cleaning can also be done by tapping, vacuuming, or blowing the dust off with compressed air. With oily dust, rinse the mat in mild solvent or warm water.
- If mat is excessively soiled, replace.

## 6.3 Oil filter

For cleaning the oil system, the compressor units Series BS/CS (not available for BS 44) have been fitted with a run-in oil filter cartridge and a locking screw. After approx. 200 operation hours replace the run-in oil filter cartridge by the standard oil filter cartridge supplied with the unit and make sure to remove the locking screw (1, Figure 17).

Afterwards replace the oil filter cartridge every 2000 to 3000 operation hour or when the indicating light 4 of KAESER CONTROL (Figure 5) comes on.

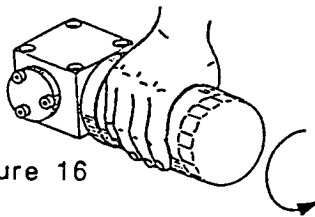

Figure 16

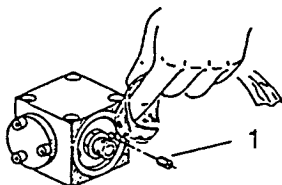

Figure 17

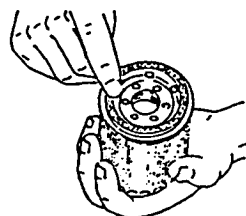

Figure 18

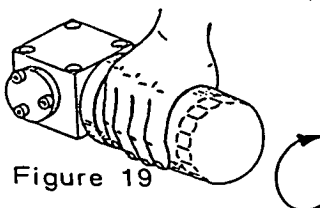

Figure 19

- Shut off the compressor (stop button and main disconnect switch).
- Place vent socket (1, Figure 22) into hose coupling (2, Figure 22) at the tank (the tank loses its pressure). Then wait about 1 minute until the oil settles.
- Unscrew clogged filter by turning the filter counterclockwise and discard. (Figure 16)
- Clean sealing surface at the filter head thoroughly with lint-free cloth. (Figure 17)
- Lubricate the new oil filter at gasket lightly with oil. (Figure 18)
- Screw in the new filter manually until the cartridge gasket fits tightly. (Figure 19) Hand-tighten only!
- Pour oil into the tank to normal level. See section 6.6.

### Important:

Remove vent socket from hose coupling. Start up the compressor and check for leakage.

### Caution:

Oil may be very hot. Allow unit to cool before working with oil system.

## 6.4 Oil separator

If the cartridge is contaminated (indicated by warning light 5 of KAESER CONTROL) replace. Start by pressing start button. The unit is ready for operation.

### 6.4.1 Filter replacement

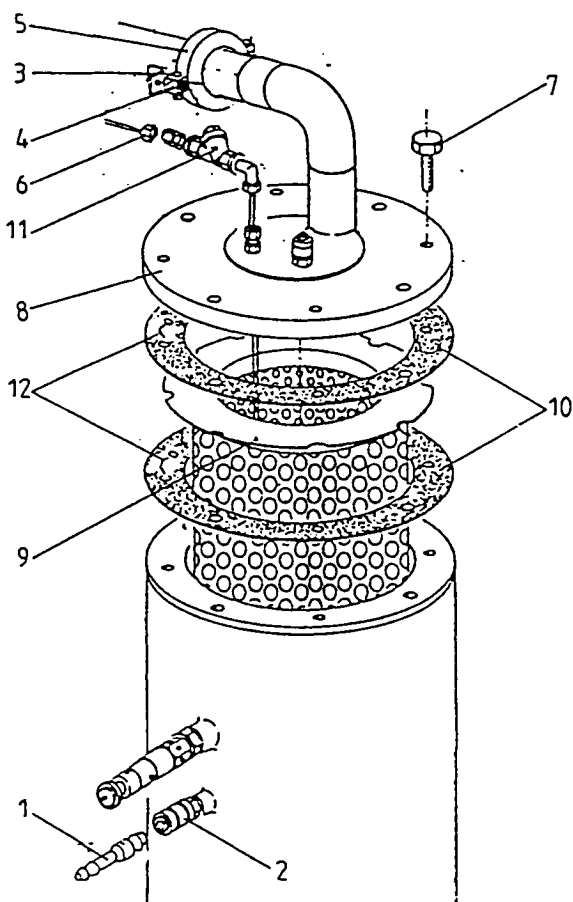

- Shut off the compressor (stop button and main disconnect switch).
- Open maintenance doors.
- Place vent socket (1) into hose coupling (2) at the tank (the tank loses its pressure).
- Loosen self-locking nuts (3) and (4) of the elastic pipe connection and remove bracket halves (5).
- Loosen pipe fitting (6), remove screws (7) and tank head (8).
- Remove the old oil separator cartridge (9) with gaskets (10) and clean gasket surfaces.
- Place in a new cartridge (9) with new gaskets (10) and fasten tank head (8) with screws (7).
- When changing the cartridge (9), unscrew and replace screen filter and o-ring from the dirt trap (11). Also replace the diaphragm, part no. 5.0999.0 on the vent valve. See section 11.7.
- Assemble parts in reverse order.
- To install elastic pipe connection. See section 6.4.2.
- Remove the vent socket (1).

**Attention**

In order that static electricity can flow through the electrically conductive oil separator cartridge to the separator tank and grounded compressor frame, the gaskets (10) of the oil separator tank cover have been provided with a metal clip (12).

Do not remove the clip!

Figure 20

**6.4.2 Mounting of the elastic pipe connection**

- Cutting edge "a" of pipe (1) has to be burr-free and surface "b" clean.
- Place cone ring holder (3) and cone ring (2) on pipe (1).
- Place pipe (1) into sleeve (7) without preliminary stress; push cone ring (2) with cone ring holder up to the cone end of sleeve (7) (realign the pipe, if necessary).
- Place the bracket halves (4) on the cone ring holder and sleeve and tighten nuts (5) according to measurement "s". Measurement "s" is a recommended value and can fluctuate by approx. 2 %.
- Tighten locking screws (8) and nuts (6) so as to allow adjusting by hand when the unit is off. When the unit is operating at full load, all screws must be under equal load.

After the self-locking nuts (5) and (6) have been tightened and loosened several times they have to be replaced.

Model	d	s	Order No.
BS 44	1 3/8 (1.38)	2 21/32 (2.66)	5.1390.0
BS	1 29/32 (1.9)	3 7/32 (3.22)	5.1391.0
CS	2 3/8 (2.38)	3 23/32 (3.72)	5.1392.0

Dimensions in inches

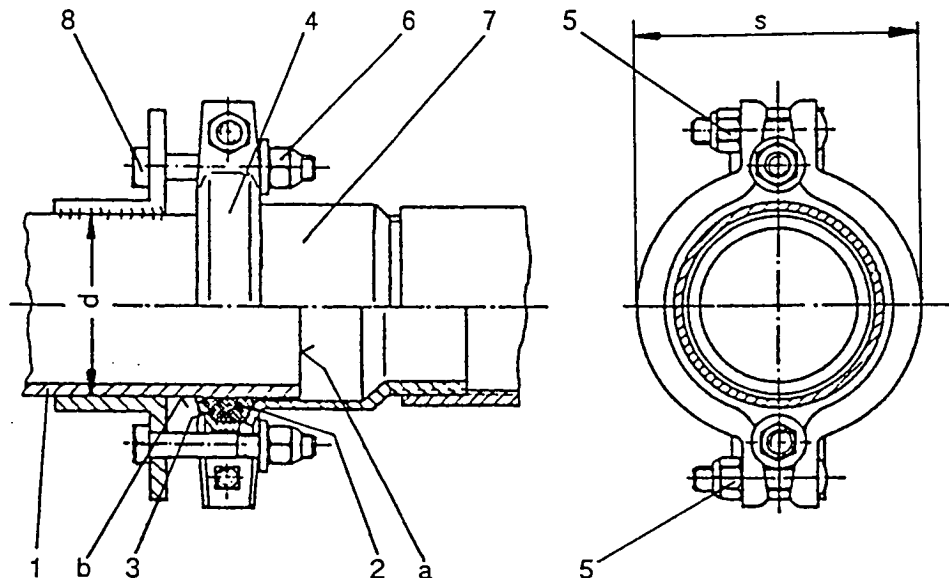







BS/CS 4/02.87

Figure 21

6.5 Compressor Oil Specifications

6.5.1 Mineral oils

	ENERGOL THB 46
	ENERGOL HLP 46
	HYSPIN AWS 46
	GST 46
	CALTEX REGAL OIL R+O
	NUTO H 46
	D.T.E OIL MEDIUM
	ROTELLA 10 W*
	X 100 Motoroil 10 W
	RANDO OIL HD 46

02.25.85

The oil used for cooling the screw compressor during operation must have the following properties:

- high ageing resistance
- high dispersive power
- low emulsifiability
- minimum capacity for forming foam

Basic oil:	solvent raffinate
Hydraulic or turbine oil:	viscosity class VG 46
Viscosity at 104°F:	approx. 42-50 cSt (200-230 SU sec)
Flash point, surface temperature:	above 392°F
Pour point:	at least 18°F below lowest ambient temperature

To ensure trouble-free operation, use only one of the oil types listed on the left. These oil types are of comparable quality and can be purchased from the listed oil companies or service stations.

The order in which the oils are listed is not indicative of or related to the quality of the oils.

The oil companies reserve the right to change the names of the oil designations!

\*Oil type "ROTELLA 10 W" is mixable with oil type "SHELL COMPTELLA OIL 46" (old name "Shell Oil S.9159") which is already in the unit.

**6.5.2 Synthetic Oils**

The following synthetic oils are recommended for use in KAESER screw compressors:

	Ambient Temperature
Kaeser Synthetic 466R	40° F to 100° F
Kaeser Synthetic 687R	Consistently above 70° F

Consult KAESER COMPRESSORS, INC. for other brands.

Extra care must be taken when changing from mineral oil use to synthetic oil or when changing oil brands. Make sure that all oil in the separator tank, oil lines, oil cooler and airend has been drained.

Kaeser Compressors recommends that the initial fill of synthetic oil be changed no later than 6000 service hours. Thereafter, the oil must be changed no later than 8000 service hours. The first oil filter must be replaced after 100 - 200 service hours and every 2000 - 3000 hours thereafter. The oil and oil filter change intervals may vary dependin on ambient conditions.

Also, when switching from mineral oil to a synthetic oil, the plant system materials must be re-evaluated. Certain plastics are not compatible with synthetic oils. The following is a partial list of acceptable and not recommended materials:

**Acceptable**

Viton  
High Nitrile Buna N  
Teflon  
Epoxy Paint  
Oil-resistant Alkyd  
Nylon  
Delrin  
Celcon

**Not Recommended**

Neoprene  
SBR Rubber  
Low Nitrile Buna N  
Acrylic Paint  
Lacquer  
Polystyrene  
PVC  
ABS

Consult KAESER COMPRESSORS, INC. for details or materials not listed.

**Caution:**  
Synthetic oils are not compatible with polycarbonate bowls. Any such bowls in the compressed air system should be covered with metal bowl guards or replaced with metal bowls.

## 6.6 Adding oil

Check oil level daily at the oil sight glass. Always shut off the compressor when checking the oil level. Oil must be added when the minimum oil level, which is the middle of the lower oil sight glass, has been reached. Fill to the middle of the upper oil sight glass, no higher.

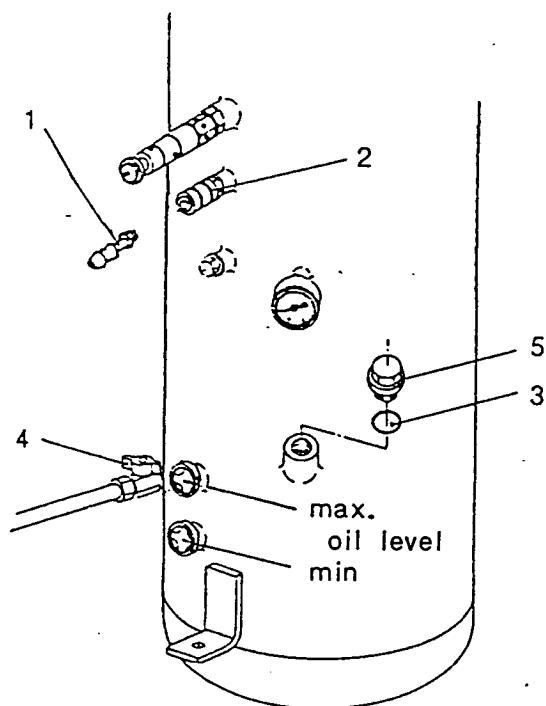

Figure 22

- Shut off the compressor (stop button and main disconnect switch).
- Open maintenance doors.
- Place vent socket (1) into coupling (2) at the tank (the tank loses its pressure).
- Loosen locking screw (5) at the filling vent.
- Pour oil in to the max. level.
- Check gasket (3) and tighten locking screw (5).
- Remove vent socket (1) from coupling.

### Important:

Always use the same make and type of oil (indicated on the oil-separator tank).

Different oil than that already in the unit may be used if it meets the oil specifications. See section 6.5. Whenever changing oil types, always drain all of old oil completely and change oil filter before adding new oil type.

**Never mix oil types, other than approved by KAESER COMPRESSORS, INC.**

**6.7 Oil change**

The oil must be changed approx. every 2000 to 3000 service hours depending on contamination of inlet air.

If the unit operates at or close to ambient temperature of 100°F (for example in boiler rooms etc.) the oil must be changed more frequently, i.e. every 1000 - 1500 hours.

**Important:**  
 Drain all oil from, the oil separator tank, cooler and lines.  
 For restart procedure see section 5.1

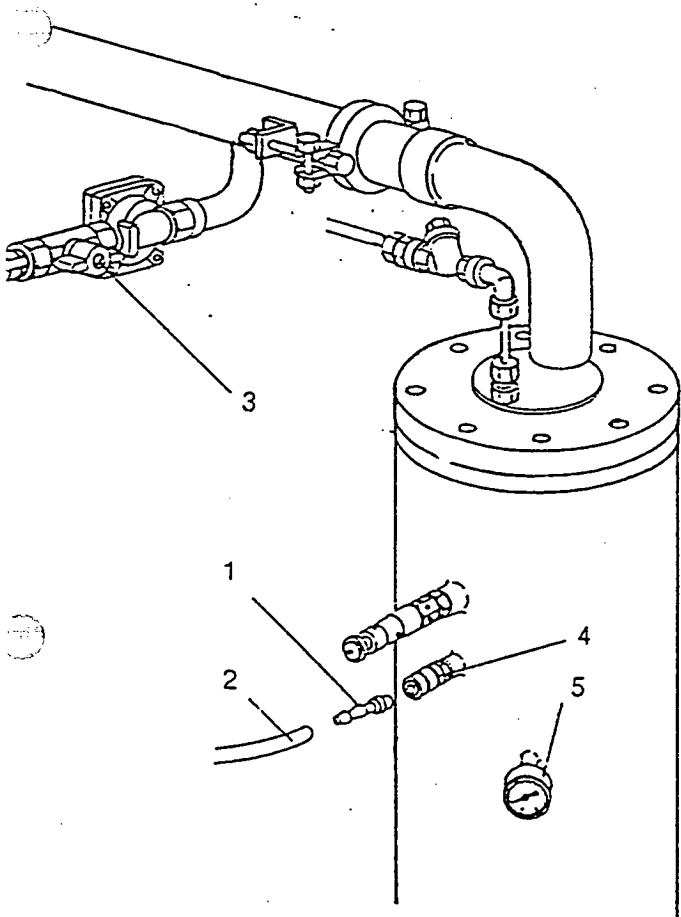

**Oil change with pressure produced by another source.**

- Shut off the compressor (stop button and main disconnect switch).
- Close shutoff valve (3).
- Hook hose (2) of other pressure source to socket (1) onto tank and pressure feed (the tank should have a pressure of approx. 30 psig).
- Remove hose with socket.
- Slowly open drain valve (4, Figure 22) (the pressure remaining in the tank will cause the oil to flow).
- After discharging the tank, slowly open the cooler drain plug (13, Figure 27) (the oil will drain without pressure).
- Close drain valve (4, Figure 22) and cooler drain plug (13, Figure 27).
- Open shutoff valve (3).
- Oil adding see section 6.6.

**Oil change with pressure produced by the compressor:**

- Shut off the compressor (stop button and main disconnect switch).
- Close shutoff valve (3).
- Let compressor run for about half a minute (the tank should have a pressure of approx. 30 psig).
- Shut off the compressor (stop button and main disconnect switch).
- Slowly open drain valve (4, Figure 22) (the pressure remaining in the tank will cause the oil to flow).
- After discharging the tank, slowly open the cooler drain plug (13, Figure 27) (the oil will drain without pressure).
- Close drain valve (4, Figure 22) and cooler drain plug (13, Figure 27).
- Open shutoff valve (3) at the tank cover.
- Oil adding see section 6.6.

Figure 23

Model	Oil charge
BS	approx 9 1/4 US Gal
CS 75/90	approx 16 US Gal
CS 120	approx 18 1/2 US Gal

**Caution**  
 Oil may be very hot.  
 Allow unit to cool before draining oil.

BS/CS 4/02.87



### 6.8 Temperature gauge and high temperature switch

When final compression temperature reaches 230° F, the compressor shuts off and warning light 2 (excessive temperature) on the KAESER CONTROL (Figure 5) comes on.

Troubleshoot and repair.

Probable causes: malfunction in the cooling system, e.g.:  
 low oil level  
 extreme ambient temperature (too low or too high)  
 clogged oil filter  
 clogged oil cooler  
 clogged filter mat

To restart, press reset (8) and start (6) buttons (Figure 4).  
 The compressor is back in operation.

### 6.9 Motor lubrication

Models BS 44 up to CS 90:

The standard motors have life-time grease lubrication.  
 Under normal working conditions (ambient temperature 80°F), carry out maintenance of the motor bearings according to the following chart.  
 After the indicated working hours, demount motor bearings, rinse them and fill the void spaces with new grease.

Model CS 120:

The standard motors are equipped with relubrication system.  
 Under normal working conditions (ambient temperature 80°F), carry out relubrication of the motor bearings according to the following chart.  
 After the indicated working hours, relubricate motor bearings with the indicated amount of grease.

Model	Lubrication interval operating hours	Amount of grease ounce
BS 44	16 000	-
BS 50	32 000	-
BS 60	32 000	-
CS 75	32 000	-
CS 90	32 000	-
CS 120	8 000	3/4

We recommend the following brands of lithium base grease:

BP Energrease LS 3  
 Calypsol H 443  
 Exxon Beacon 3  
 Mobilux Grease 3  
 Shell Alvania 3  
 SKF Waelzerol FL

Under harder working conditions, i.e. strongly polluted intake air and ambient temperature of the unit, approx. 105° F, lubrication interval is half as long.

For special motors, other protective systems etc., follow manufacturer's instructions (on motor name plate).

**6.10 V-belt tension**

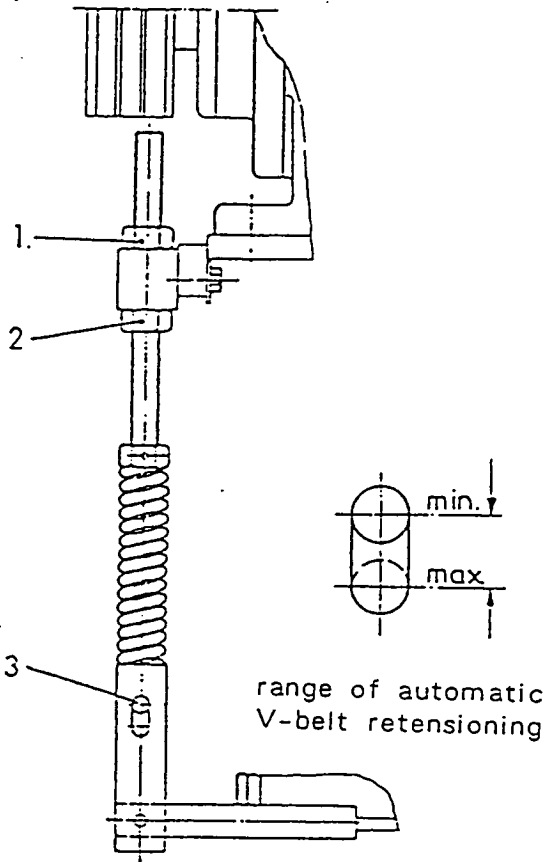

Figure 24

**6.10.1 V-belt changing**

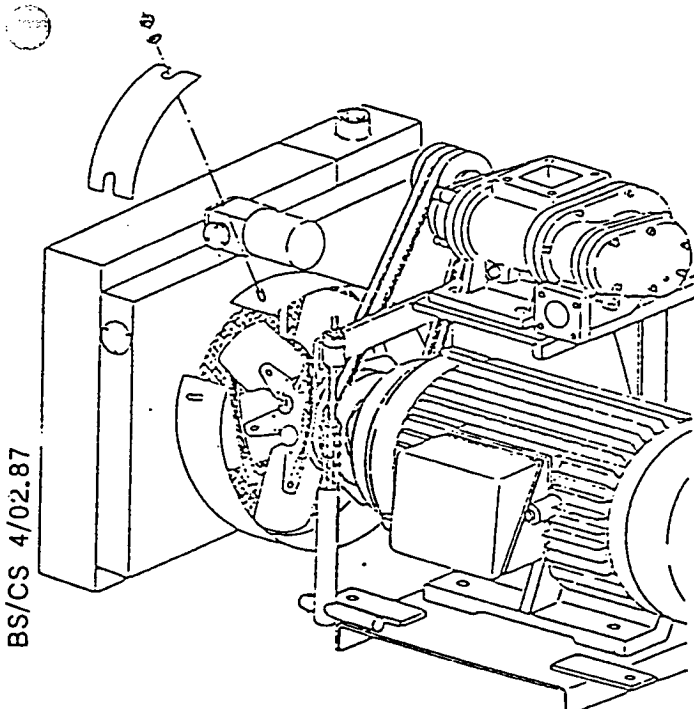

Figure 25

Belt tension must be checked every 500 operating hours.

The V-belt span is adjusted automatically within a limited range by the pressure spring. See figure at left.

An indicator pin (3) in the oblong hole indicates the V-belt span. When the pin (3) reaches the top of the hole, retensioning is required.

- Shut off the compressor (stop button and main disconnect switch).
- Loosen hex nut (1).
- Retension the V-belt by turning the hex nut (2) until the pin (3) is all the way down.
- Retighten hex nut (1).

- Shut off the compressor (stop button and main disconnect switch).
- Unscrew and remove covering plate from fan frame.
- Turn adjusting hex nut (2, Figure 22) downwards.
- Place V-belt first over the free-standing fan blade, then turn fan and move belt over the other blades.
- Slip V-belt over motor and compressor pulleys.
- Tension V-belt see section 6.10.
- Fasten covering plate on the frame.
- Check V-belt tension after approx. 2 and 24 operating hours. (See section 6.10).

**Important:**

Spare V-belts must absolutely have the same length and must be 100 % oil resistance. We, therefore, recommended the genuine Kaeser V-belts be used.

### 6.11 Cleaning the cooler

Check cooler at least every 1000 operating hours for contamination through an inspection hole (1). Strong contamination can result in excessive temperature in oil circulation.

Disassembling and cleaning the cooler:

- Shut off the compressor (stop button and main disconnect switch).
- Vent the unit (see section 6.4.1).
- Remove covering wall (2) and open maintenance doors (3).
- Discharge compressed air line.

**Attention:**

When the unit has been vented, pressure is provided from the air lines up to the minimum pressure check valve (4). Therefore, disconnect the unit from the air mains (shut-off valve). After that vent the air aftercooler by demounting the compressed air line (12) carefully. If no shut-off valve is provided, the complete air lines must be vented.

- Demounted elastic pipe connection (5) and control line (6).
- Screw off combination valve (7) from cooler (8), left it slightly and wipe off the oil flowing out with a piece of cloth. Remove o-rings and check them.
- Close the openings of the oil lines at the cooler (8).
- Undo attachment screws (9) and swivel the cooler (8) outwards.
- Blow cooling fins clean with compressed air or spray with water.
- Check foam kit (10) of fan housing (11).
- Assemble part in reverse order.
- While mounting combination valve (6), make sure o-rings are seated properly.
- For mounting elastic pipe connection see section 6.4.2.

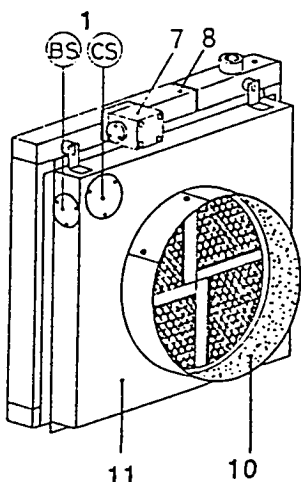

Figure 26

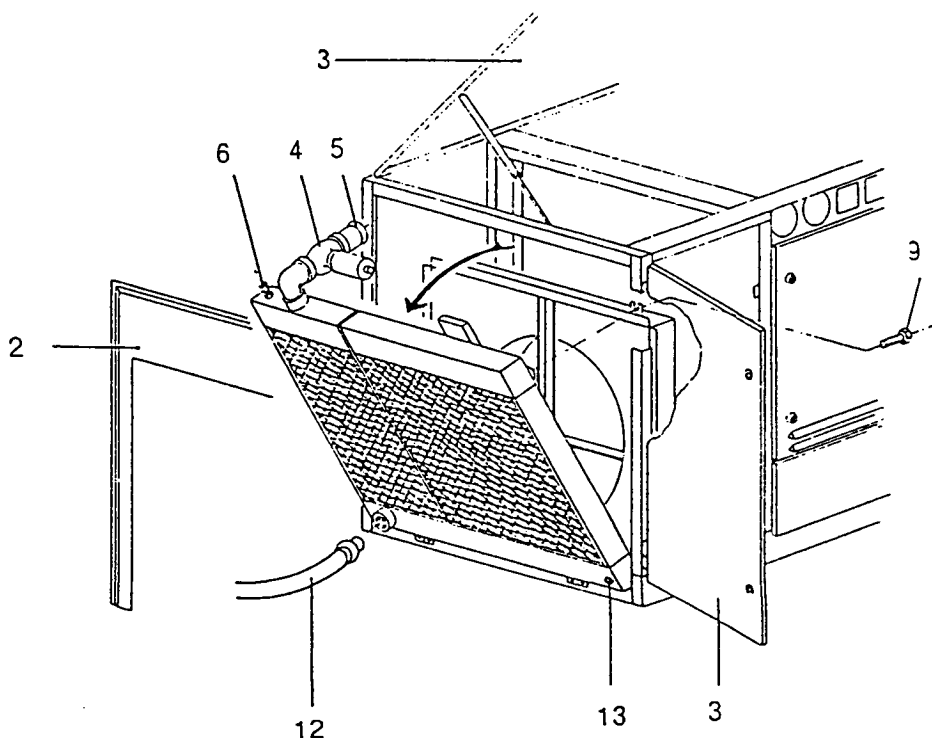

Figure 27

## 6.12 Checking the safety valve on the oil separator tank

To check the set maximum operating limit the unit must be operated at a final pressure higher than maximum setting of the pressure switch.

Maximum pressure of the unit	Set maximum operating pressure of the safety valve
110 psig	130 psig*
145 psig	175 psig
190 psig	210 psig

In order to avoid readjustment of the pressure switch, carry out checking in the following way:

- Shut off the compressor (stop button and main disconnect switch).
- Close the shutoff valve (3, Figure 23) at the discharge line.
- Close the shutoff valve downstream of the unit.
- Start the compressor and let it switch over from full load to idling.
- While the discharge line is being closed the pressure can easily be checked at the pressure gauge (5, Figure 23) on the separator tank as it is increased slowly up to the limit where the safety valve will react.
- Shut off the compressor.
- Open the shutoff valve downstream of the unit.
- Open the shutoff valve (3, Figure 23) at the discharge line.

**6.13 Maintenance parts list**

Model	Maximum pressure psig	V-belt		Oil filter cartridge	Oil separation cartridge compl.set	Air inlet filter cartridge	Filter mat
		pcs.	compl.set Order No.	Order No.	Order No.	Order No.	Order No.
BS 44	110	4	6.2540.0	6.1981.0	6.2012.0	6.1996.0	6.1938.0
	145	4	6.2540.0				
	190	4	6.2540.0				
BS 50	110	6	6.1434.0	6.1981.0	6.2012.0	6.1996.0	6.1938.0
	145	6	6.2533.0				
	190	6	6.2542.0				
BS 60	110	6	6.2532.0	6.1981.0	6.2012.0	6.1996.0	6.1938.0
	145	6	6.1434.0				
	190	6	6.2533.0				
CS 75	110	9	6.1432.0	6.1981.0	6.2013.0	6.1997.0	6.1945.0
	145	9	6.2521.0				
	190	9	6.2522.0				
CS 90	110	9	6.1432.0	6.1981.0	6.2013.0	6.1997.0	6.1945.0
	145	9	6.2521.0				
	190	9	6.2522.0				
CS 120	110	9	6.2529.0	6.1981.0	6.2013.0	6.1997.0	6.1945.0
	145	9	6.1432.0				
	190	9	6.1432.0				

The oil separating cartridge set (Order No. 6.2012.0) consists of:

pcs.	Order No.	Name
1	6.1960.0	Separating cartridge
2	5.0556.0	Gasket
1	8.0394.0	Dirt-trap strainer
1	5.1443.0	O-ring

The oil separating cartridge set (Order No. 6.2013.0) consists of:

pcs.	Order No.	Name
1	6.1965.0	Separating cartridge
2	5.0566.0	Gasket
1	8.0394.0	Dirt-trap strainer
1	5.1443.0	O-ring

When ordering spare parts always state compressor type, serial number and year of manufacture which are stamped on the name plate.

**Important:**

Order KAESER genuine factory-tested replacement parts only !!

**6.14 Recommended maintenance schedule for model BS/CS**

Interval	Maintenance	Refer to section
50 hrs after initial start up	Tighten all wiring connections in the control panel	
100 to 200 hrs after initial start up	Replace oil filter	6.3 Oil filter
Weekly	Check oil level	6.6 Adding oil
100 to 300 hrs	Clean filter mat	6.2 Filter mat
Every 500 hrs	Check V-belt tension	6.10 V-belt tension
Every 1000 hrs	Check cooler for surface dirt*	6.11 Checking the cooler
Every 2000 hrs	Check safety system	5.4 Safety system
Every 2000 hrs to 3000 hrs	Change oil (if mineral oil is used)*	6.7 Oil change
Indicated by KAESER CONTROL	Clean or replace air inlet filter*	6.1 Air inlet filter
	Change oil filter*	6.3 Oil filter
	Change separator cartridge*	6.4 Oil separator
Every 6000 to 8000 hrs	Change synthetic oil (if used in place of mineral oil)*	6.7 Oil change
Every 8000/16000 or 32000 hrs	Lubricate motor bearings*	6.9 Motor lubrication
Yearly	Clean cooler surfaces*	6.11 Checking the cooler
	Tighten all wiring connections in the control panel	
	Check safety valve	6.12 Checking the safety valve

\* Note:

Time interval may vary depending on type of unit, installation (e.g. boiler room), frequency of use, and ambient conditions (e.g. ambient temperature other than 32 - 105° F), please consult KAESER COMPRESSORS, INC.



7. Wiring Diagram for BS/CS, St 501.515.1 Page 1

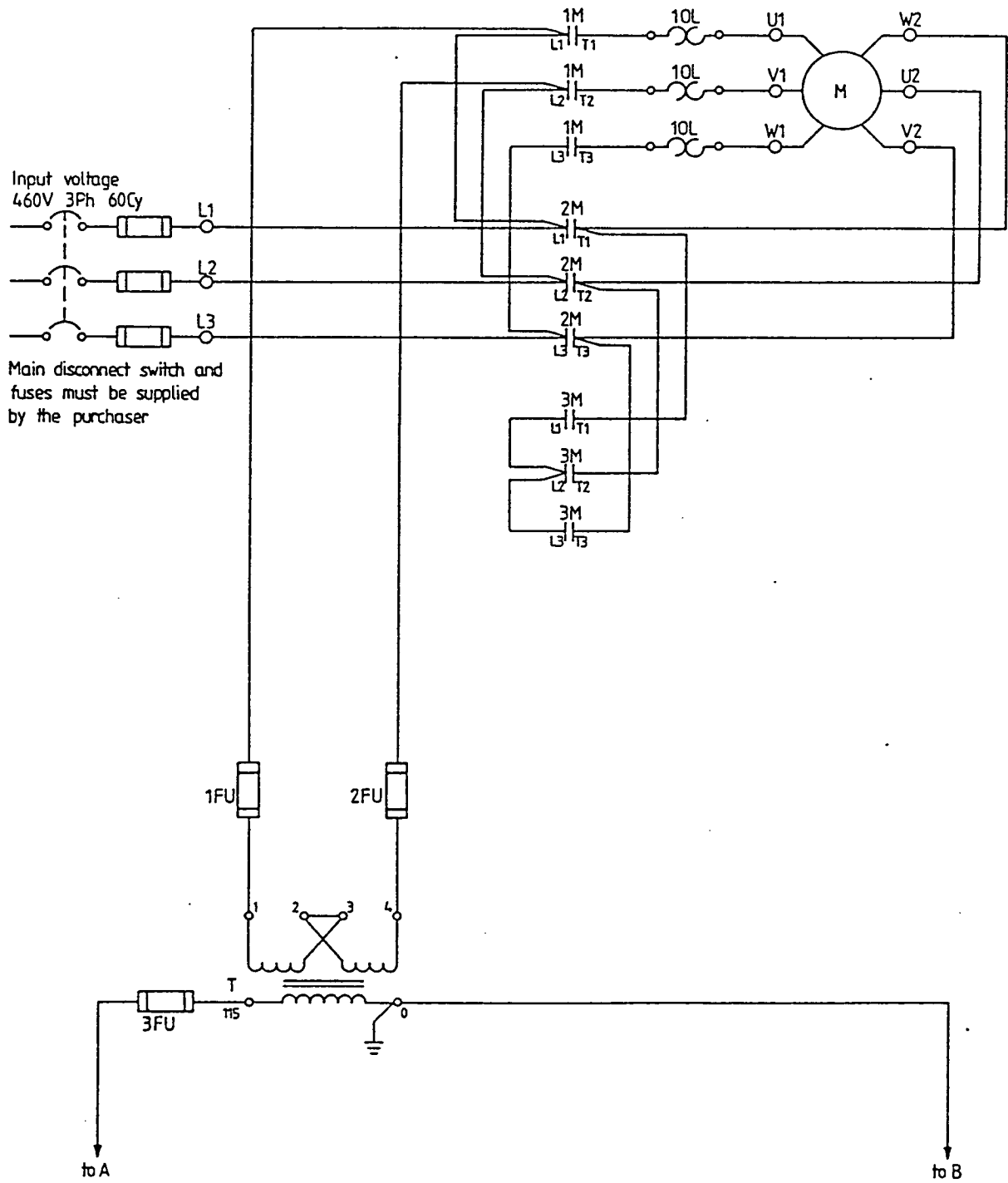



7. Wiring Diagram for BS/CS, St 501.515.1 Page 2

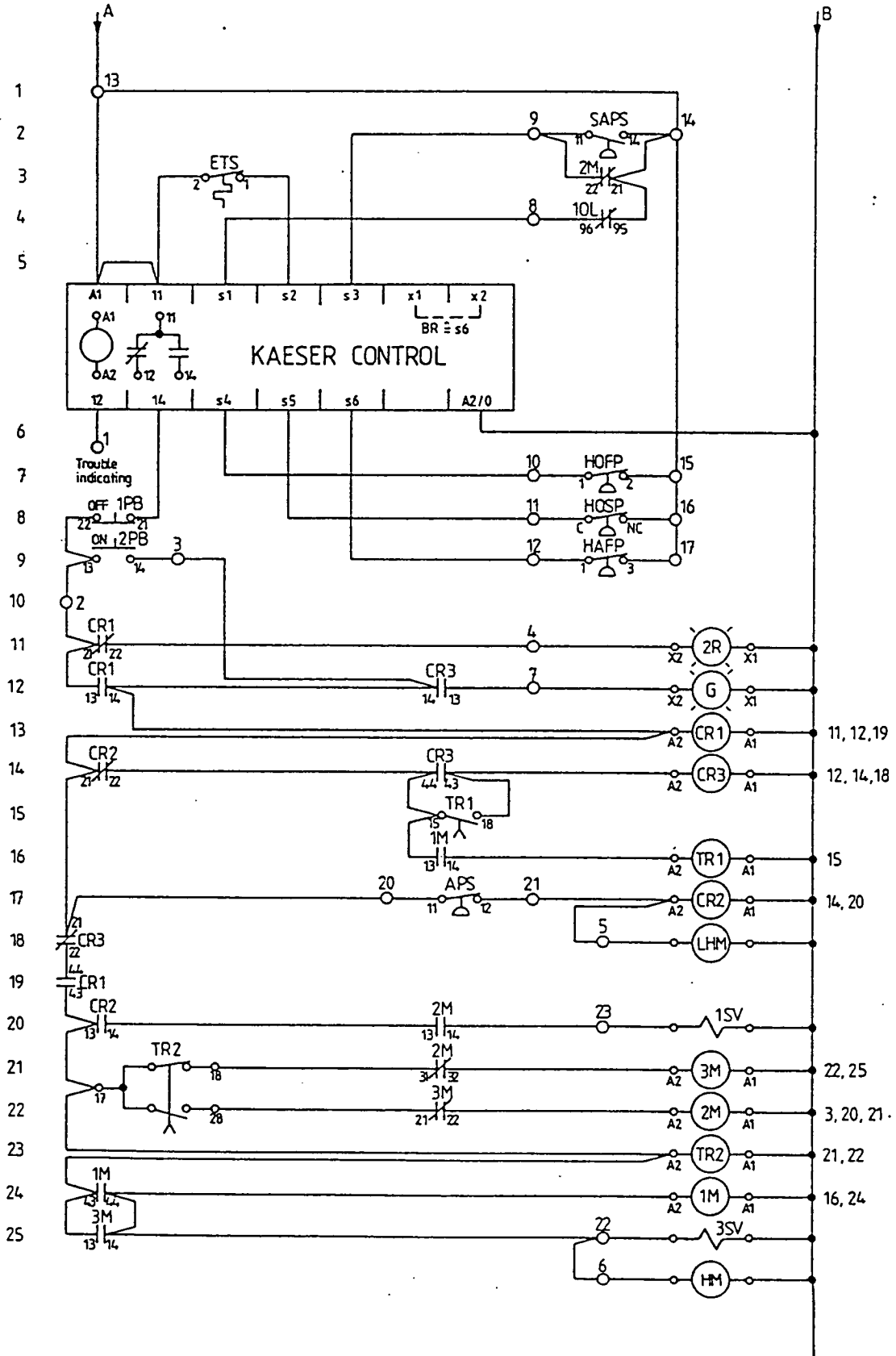

7. Wiring Diagram for BS/CS, St 501.515.1 Page 3

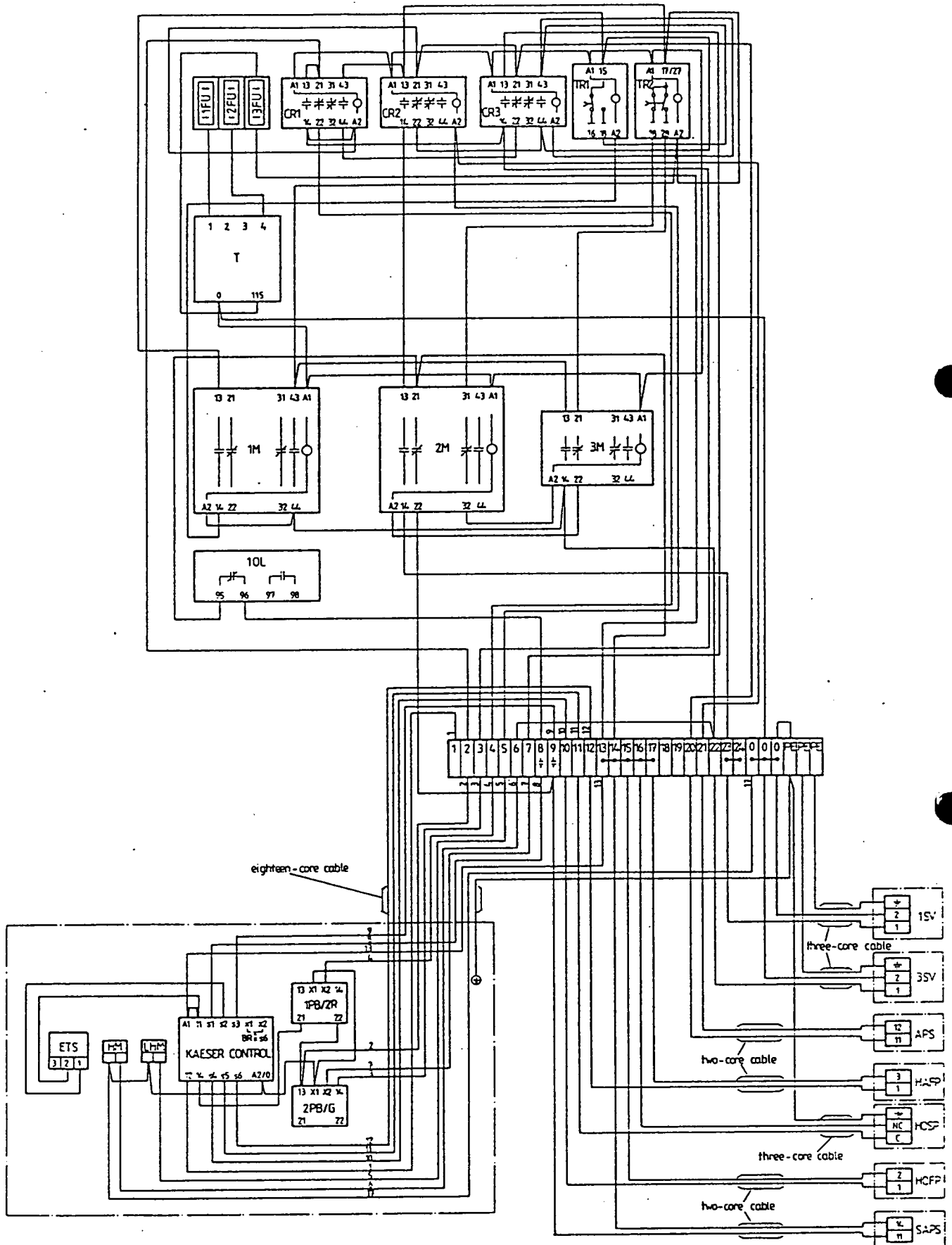

## 7. Wiring Diagram for BS/CS, St 501.515.1 Page 4

1M Motor starter (main contactor)  
 2M Motor starter (delta contactor)  
 3M Motor starter (weye contactor)  
 1,2,3FU Fuse (transformer)  
 T Transformer  
 M Motor  
 APS Air pressure switch  
 CR1/2/3 Control relay  
 1SV Solenoid valve (controls inlet valve /  
 discharge valve)  
 3SV Solenoid valve (oil stop)  
 TR1 Time delay relay (delay - off)  
 TR2 Time delay relay (weye time)  
 1PB Push button "off"  
 2PB Push button "on"  
 G Indicating light (green, ready for operation)  
 1R Indicating light (red, off)  
 HM Hour meter  
 LHM Load hour meter

### Malfunction Indicators:

10L Overload relay for motor	} shutdown functions
ETS Excessive temperature switch	
SAPS Safety air pressure switch	
HOFP High oil filter pressure	} indicating lights
HOSP High oil separator pressure	
HAFP High air filter pressure	

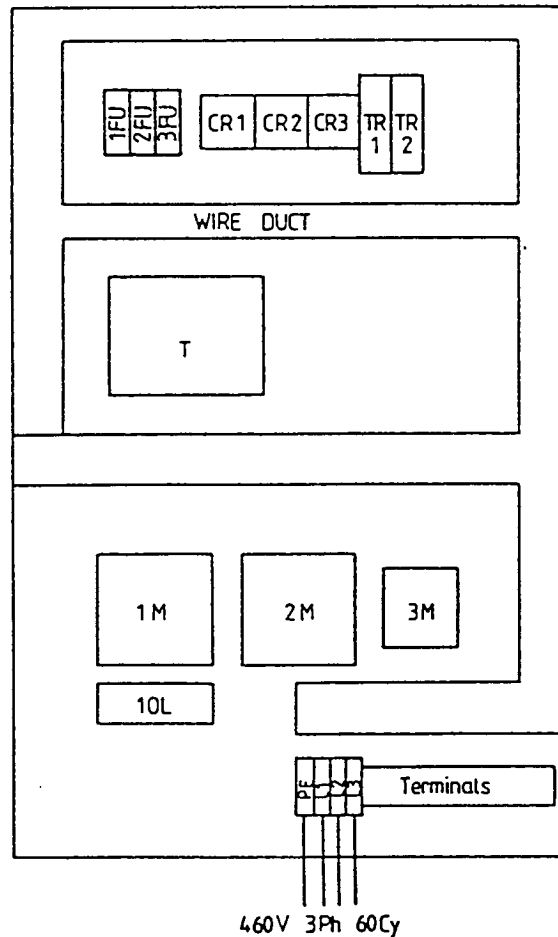

8. DIMENSIONAL DRAWING BS-- air cooled

with soundproofing casing

Dimension in inches

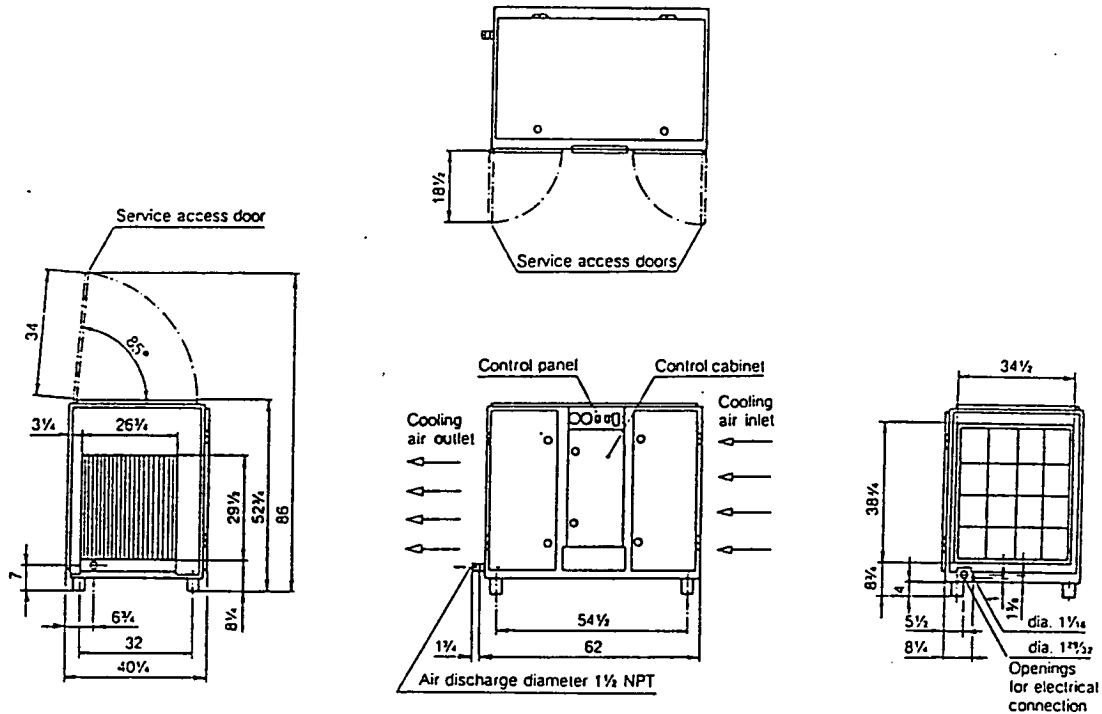

with super soundproofing casing

Dimension in inches

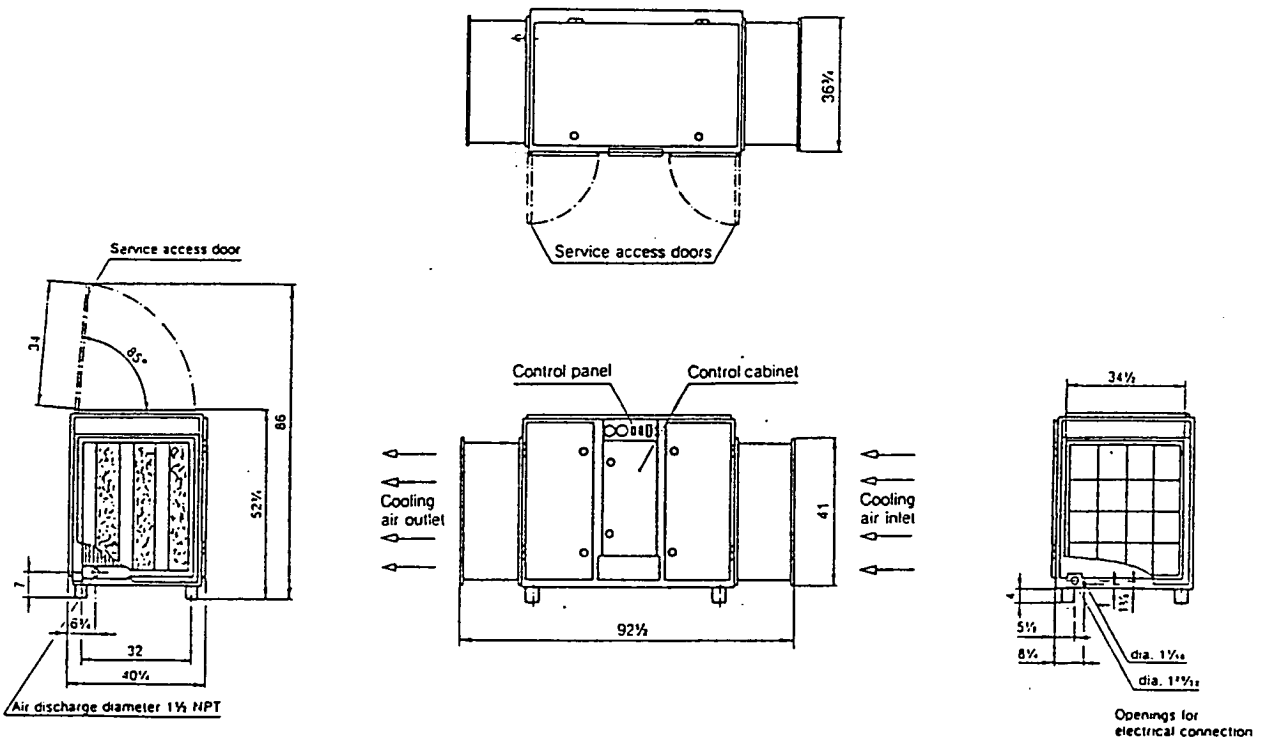

8. DIMENSIONAL DRAWING CS - air cooled

with soundproofing casing

Dimension in inches

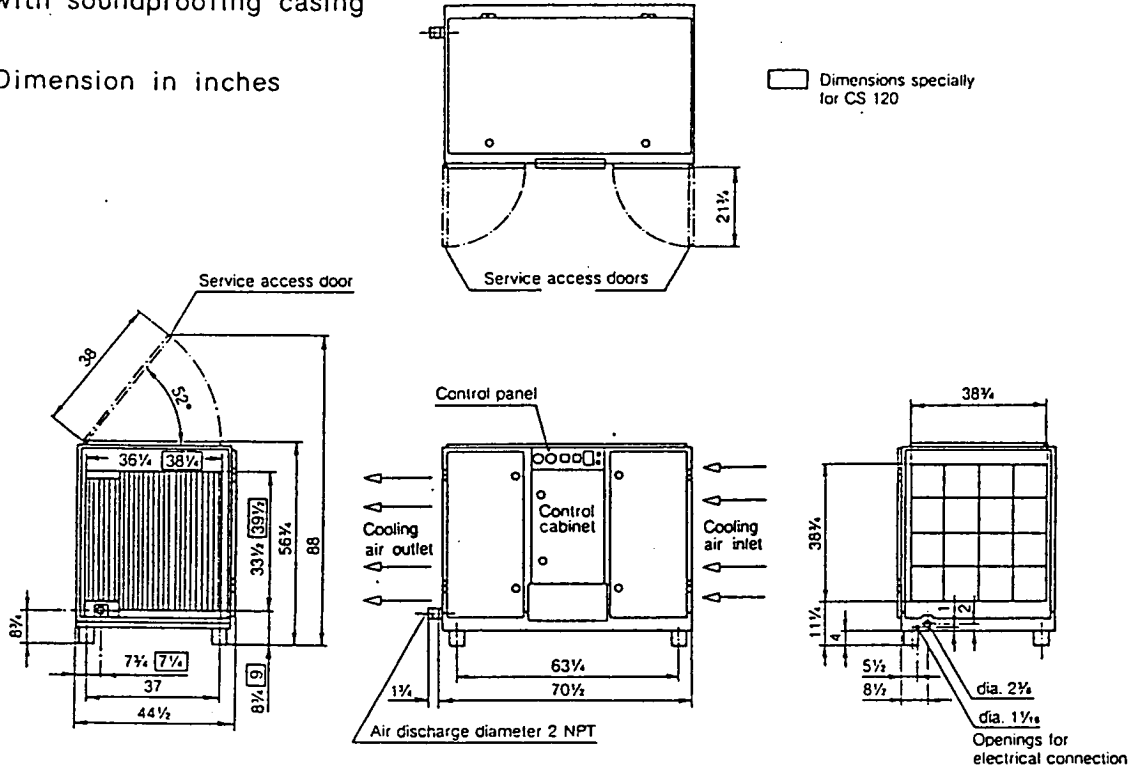

with super soundproofing casing

Dimension in inches

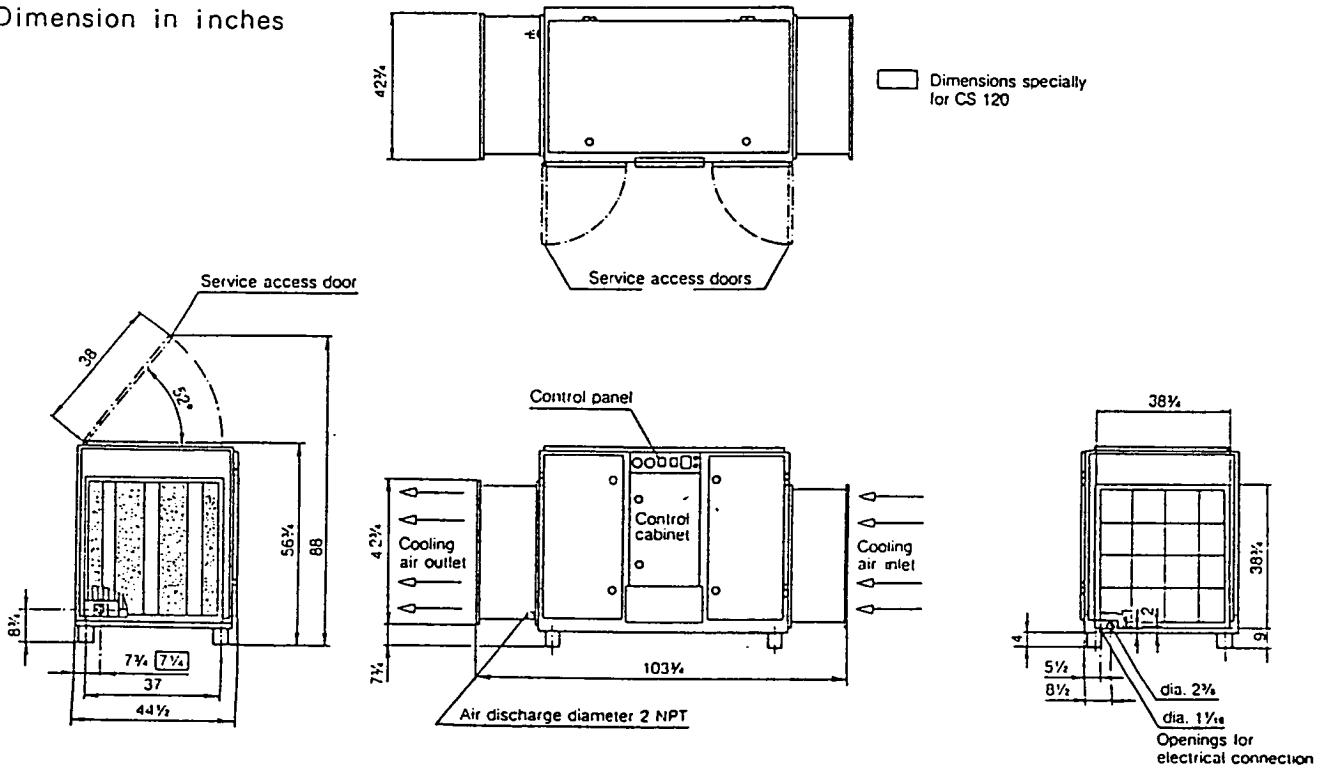

**9. TRANSPORT INSTRUCTIONS**

To avoid damage of the casing of the unit, it is recommended a fork lift or an adjustable spreader beam be used for transportation.

Model	Weight
BS 44	approx. 1520 lbs
BS 50	approx. 1850 lbs
BS 60	approx. 1940 lbs
CS 75	approx. 2490 lbs
CS 90	approx. 2600 lbs
CS 120	approx. 2930 lbs

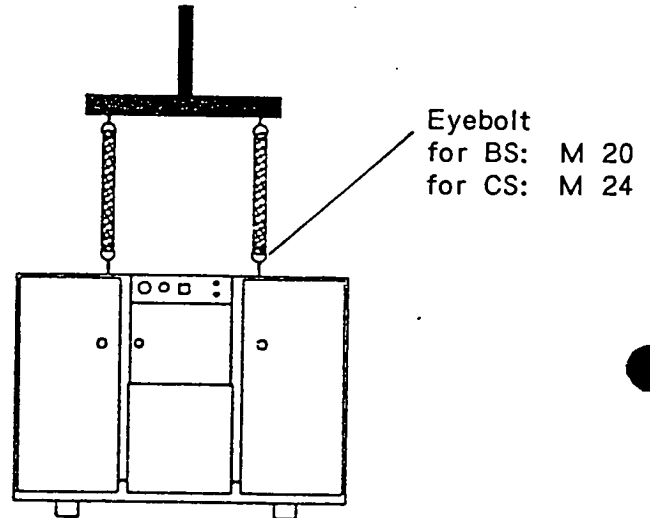

Dimension in inches

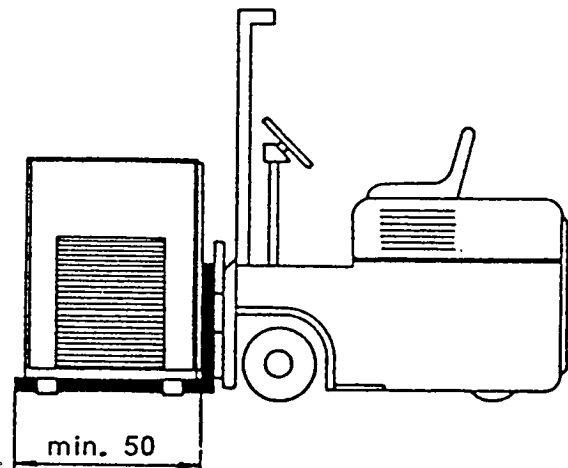
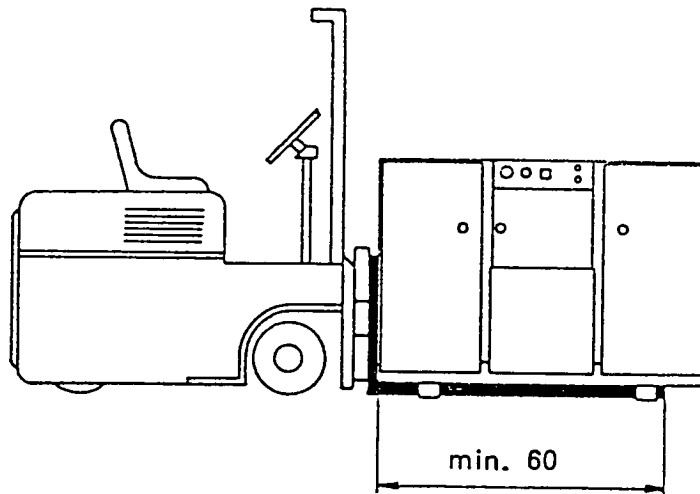

**10. TROUBLE SHOOTING**

**10.1 Aired temperature is too high (greater than 155 - 180°F)**

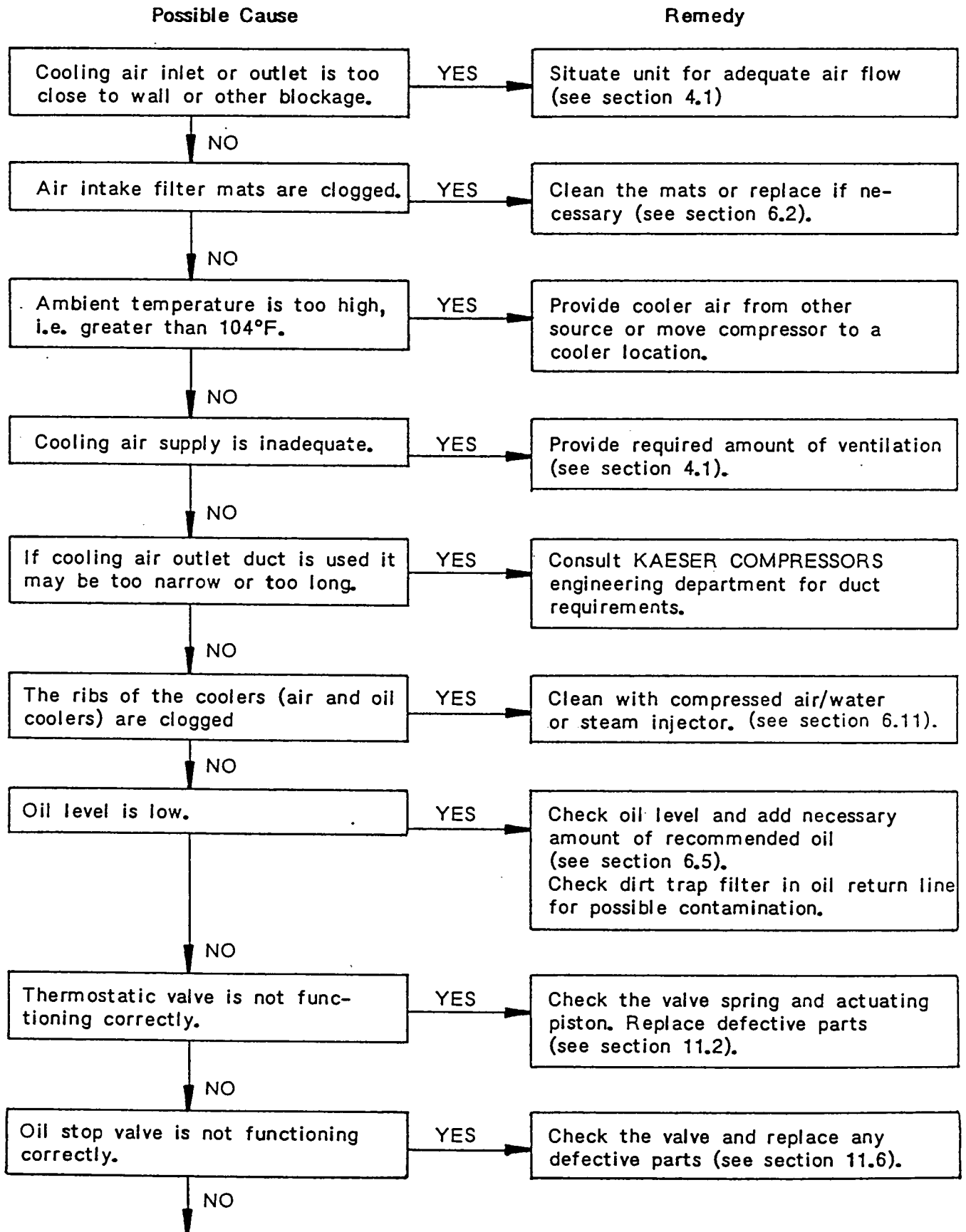

BS/CS 04/03.86

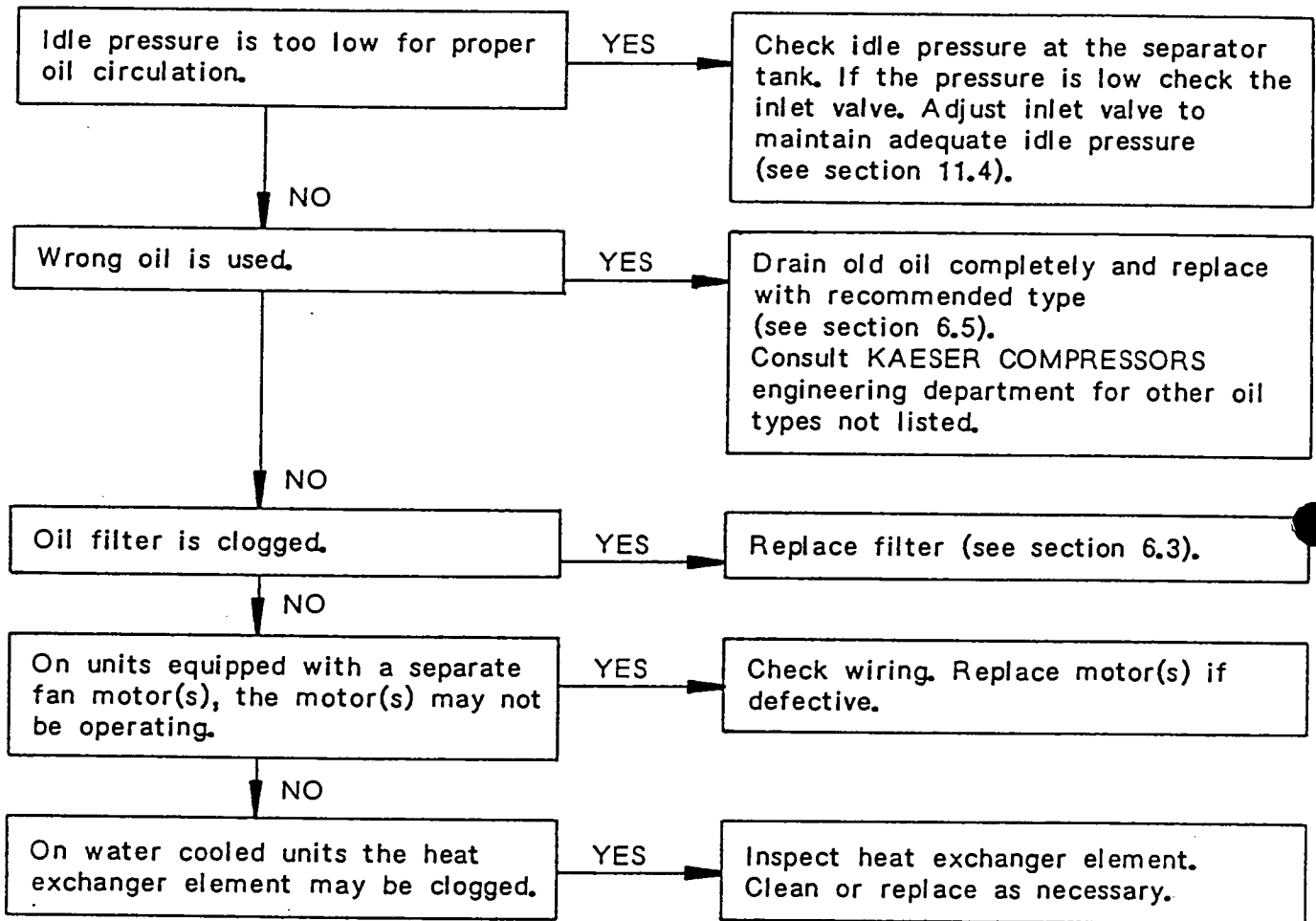



10.2 Motor overload relay switches the unit off

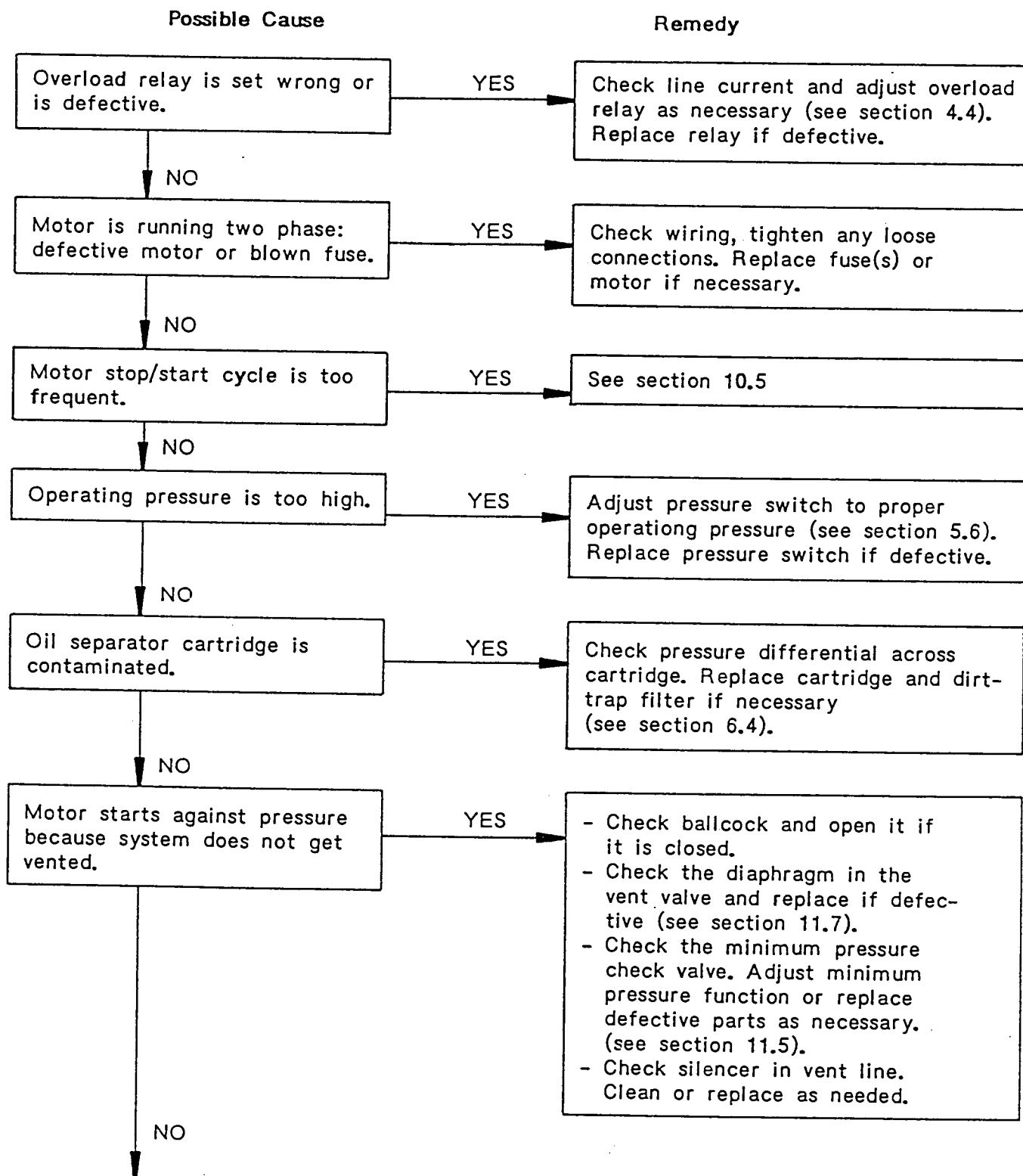

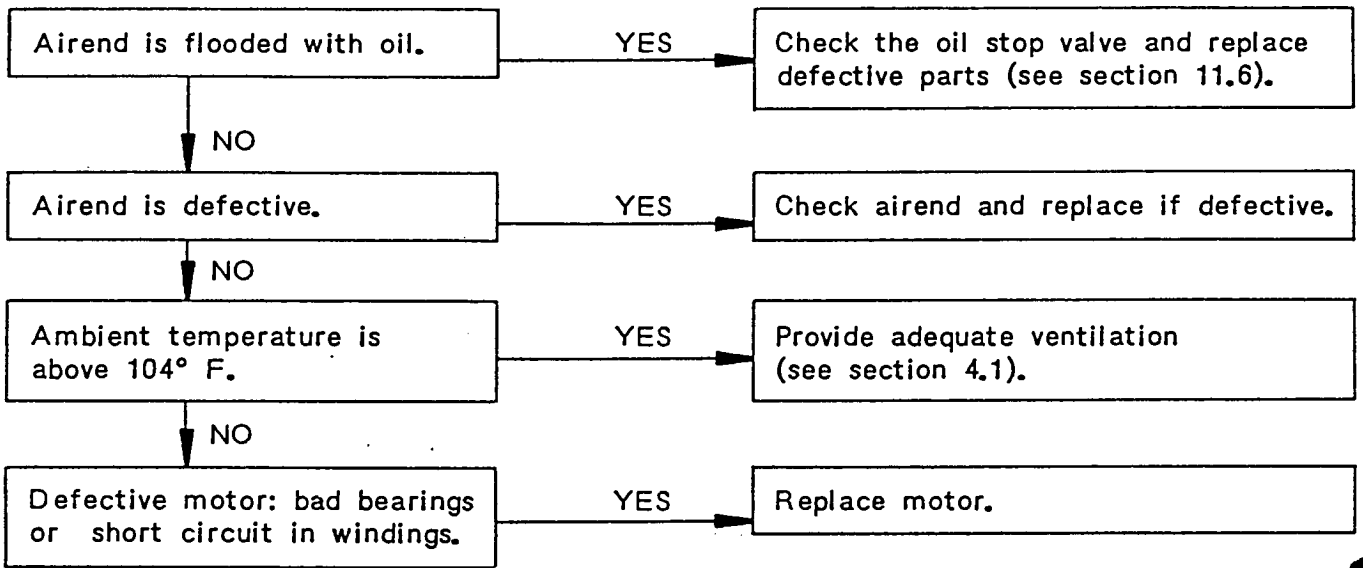

10.3 Compressor is running but produces no pressure

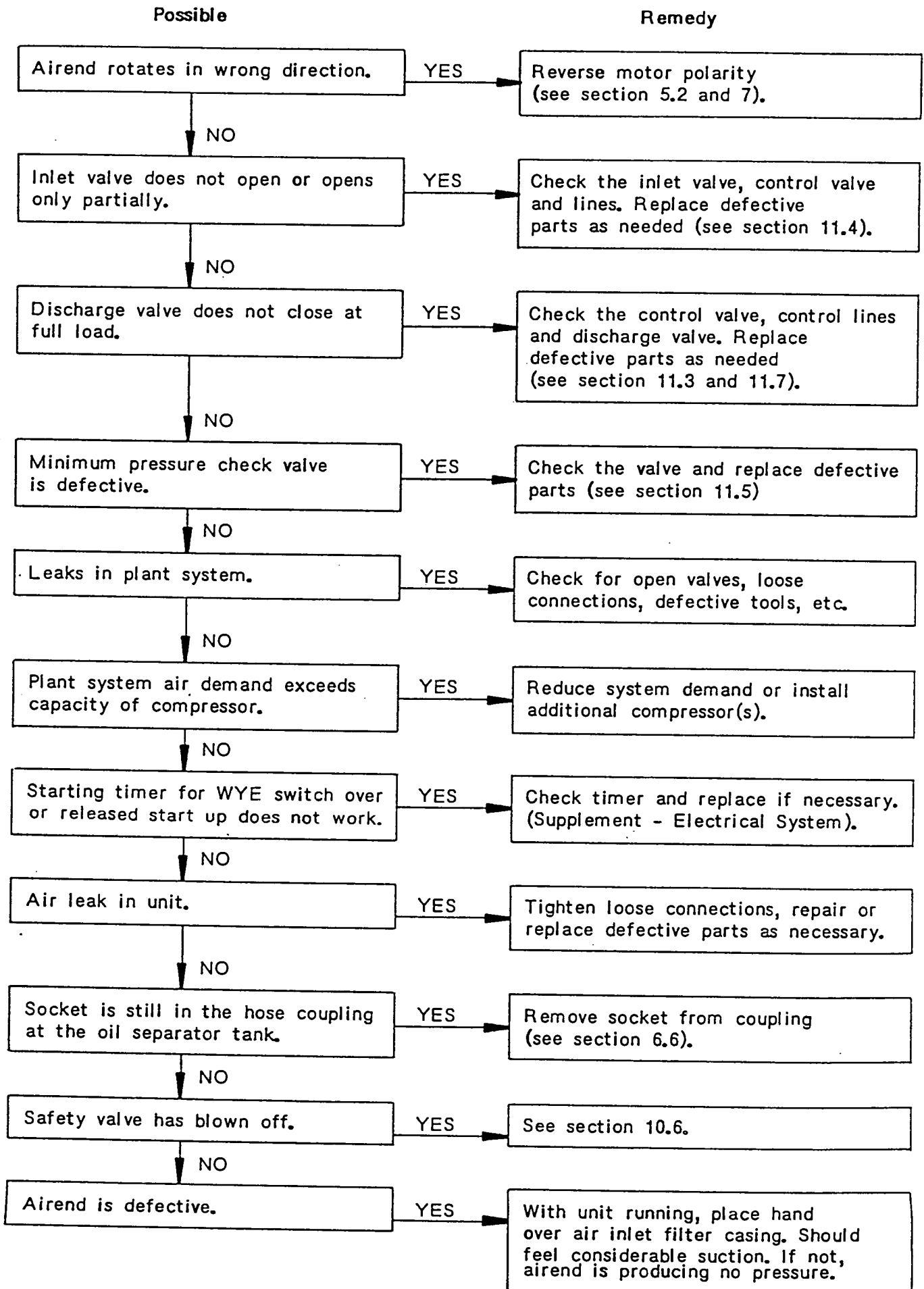

BS/CS 04/03.86

**10.4 Oil flows out of air filter**

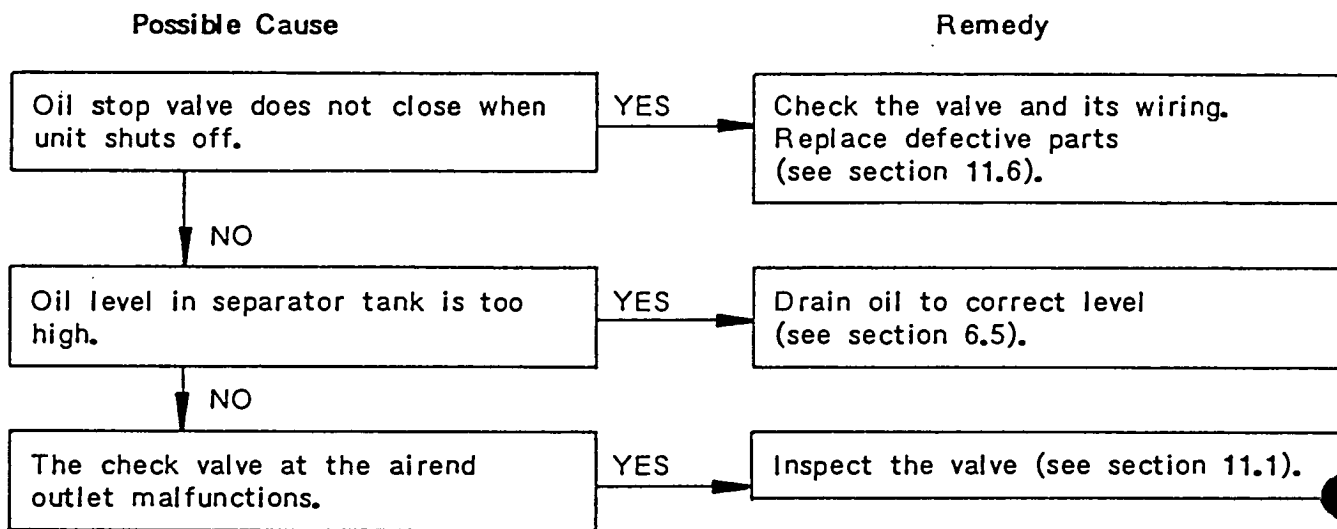

**10.5 Full-load/Idle sequence occurs too frequently**

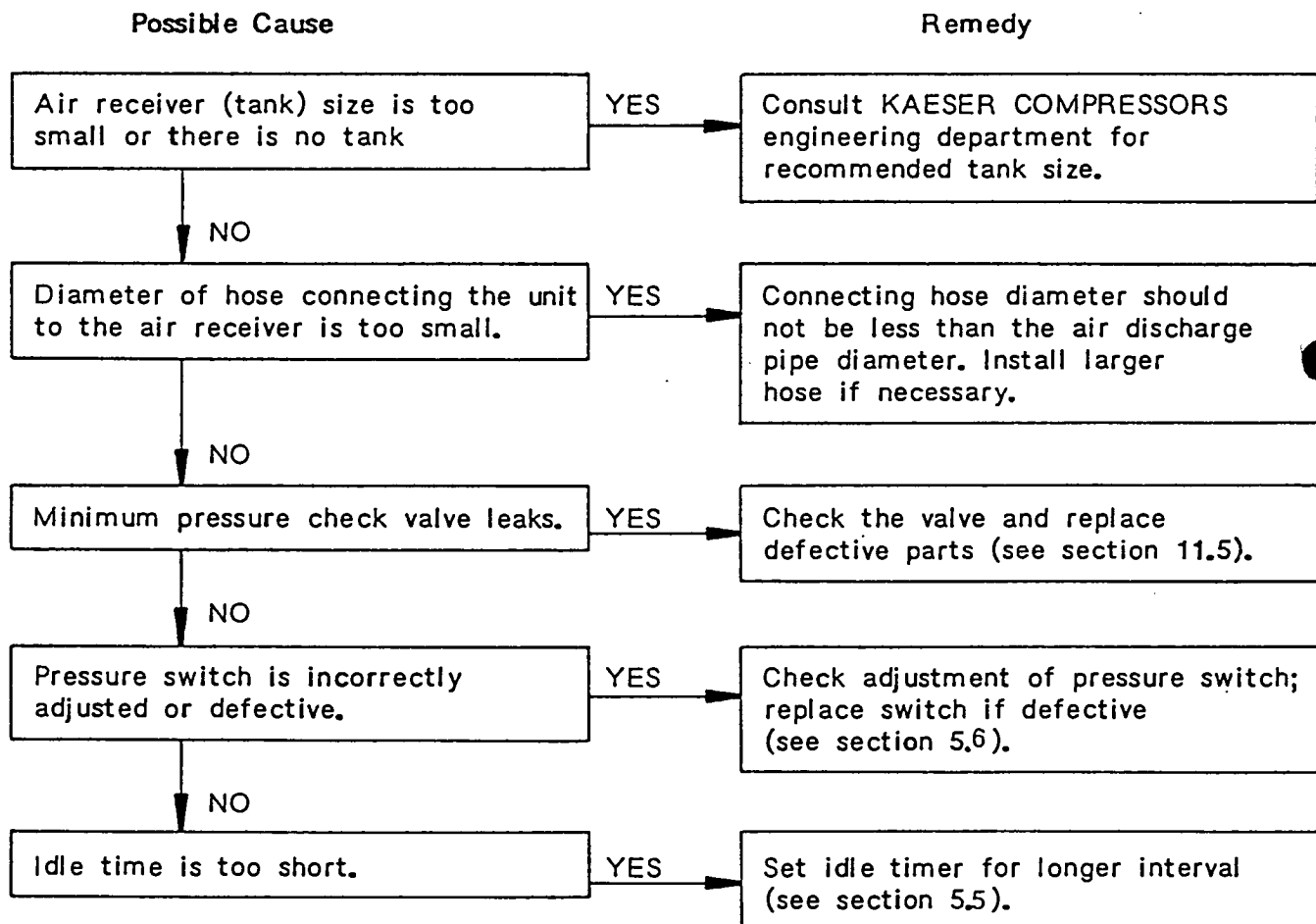

BS/CS 04/03.86

10.6 Safety-valve blows off

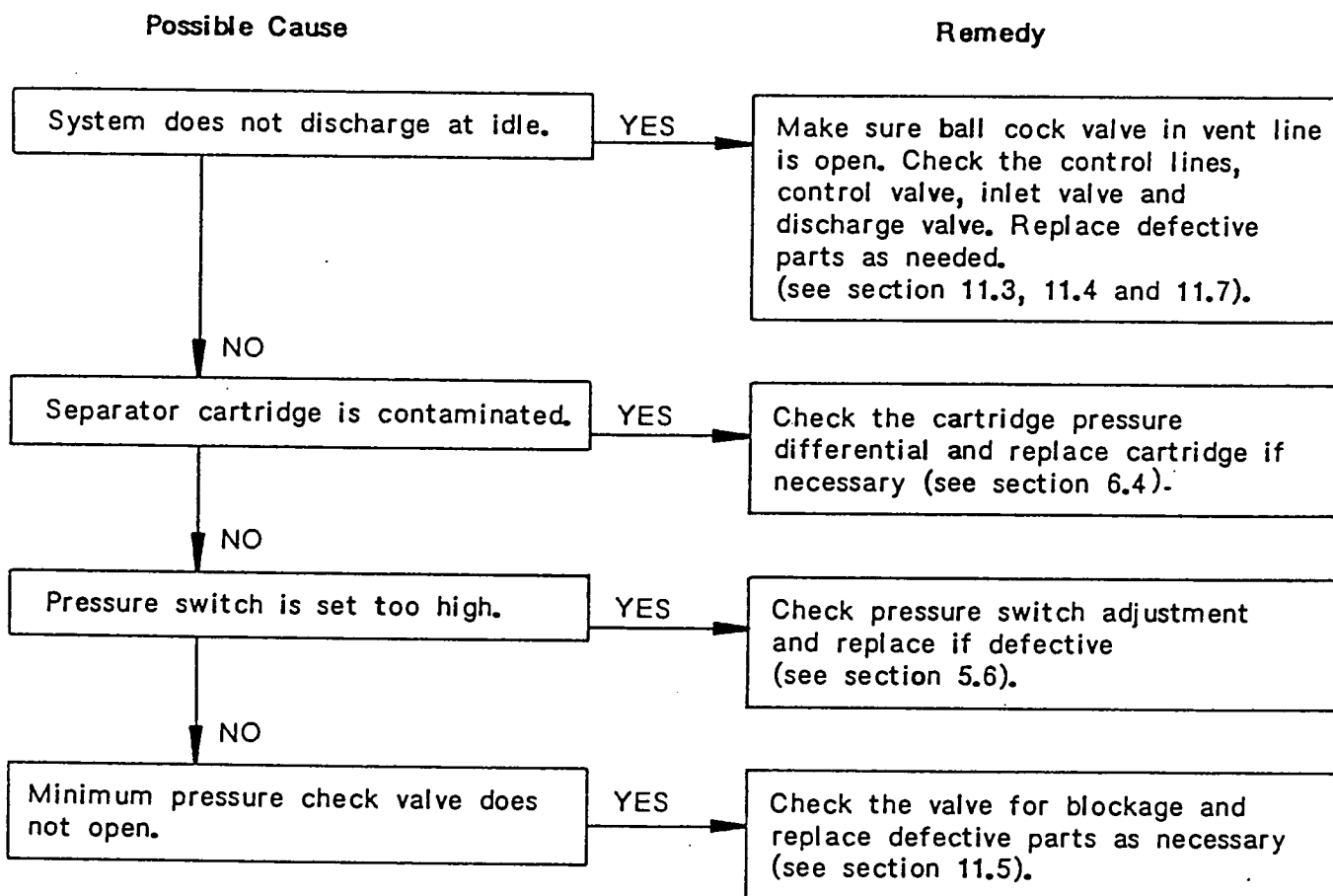

10.7 Oil in the unit enclosure

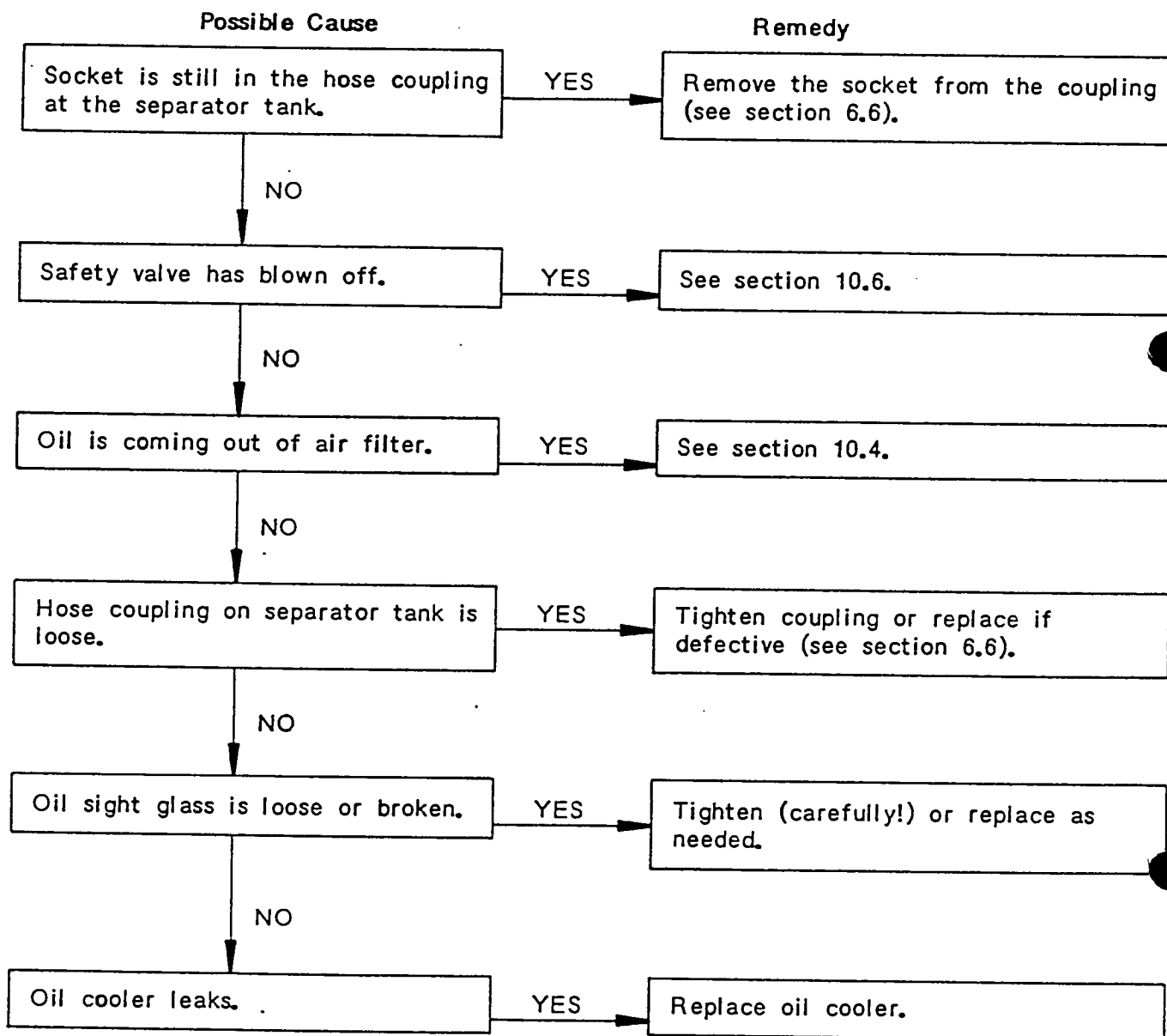

10.8 Excessive oil consumption

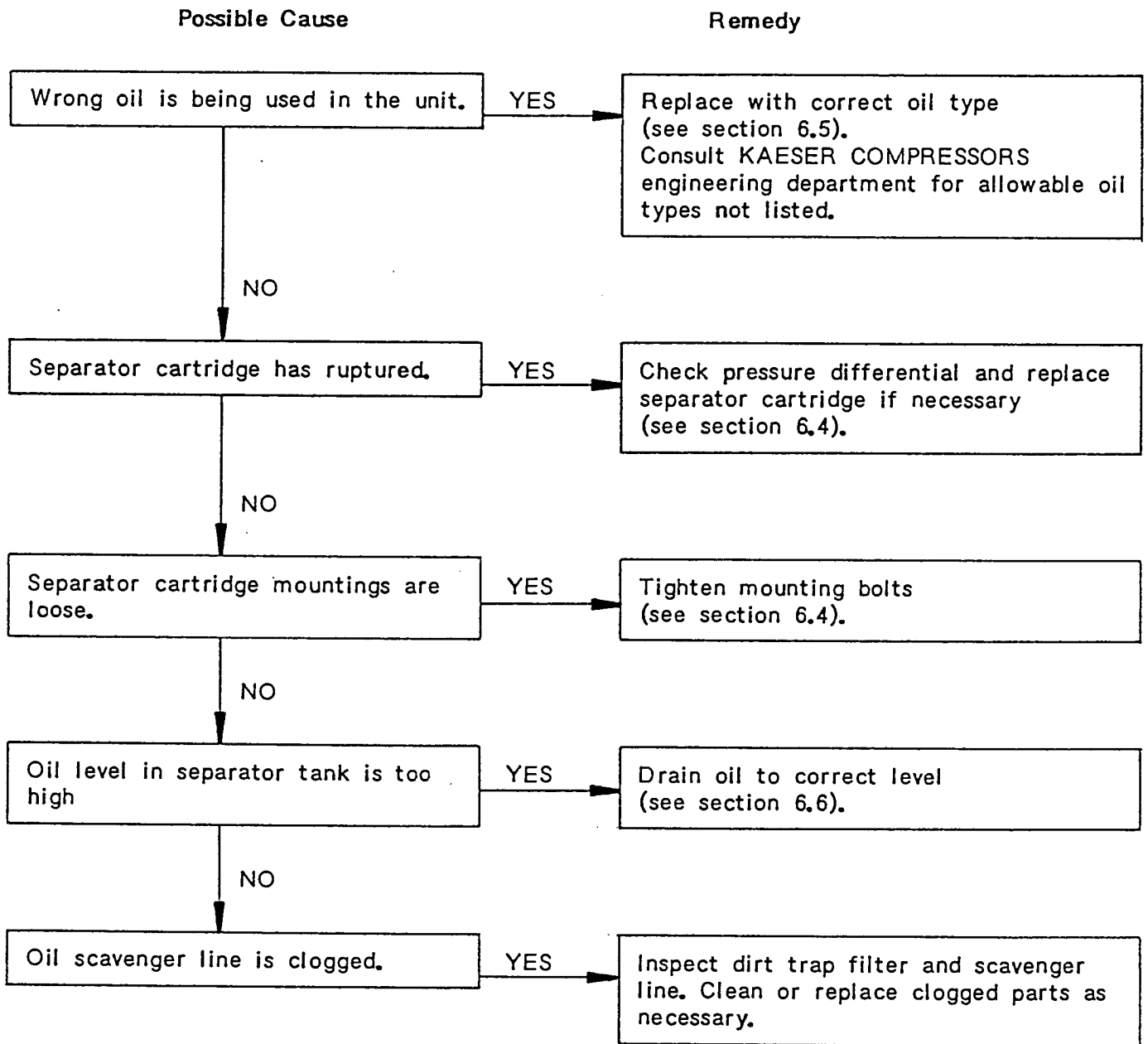

**11. VALVE SERVICE SUPPLEMENT**

**11.1 Check Valve**

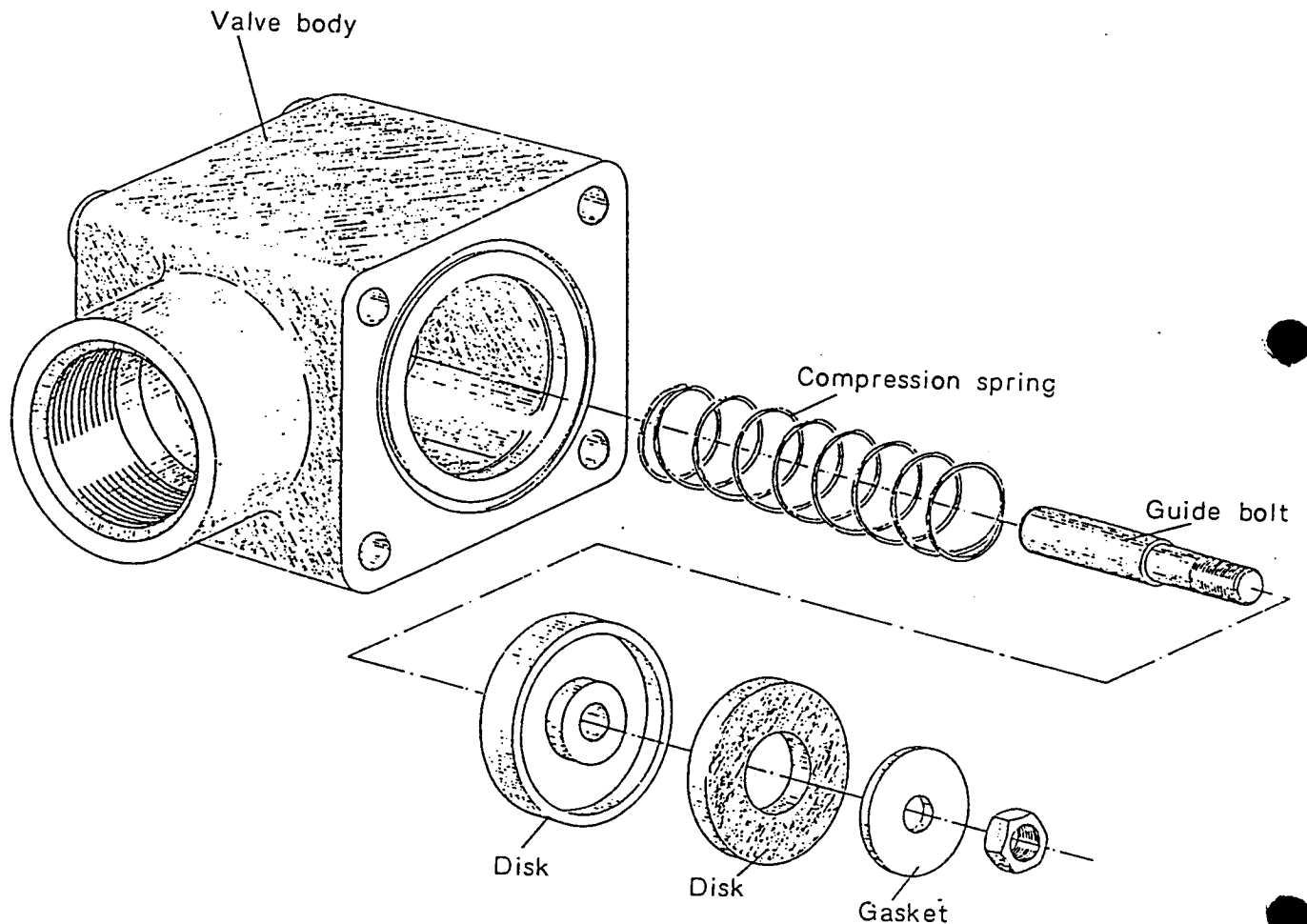

**Function**

To prevent the backflow of oil-air mixture into airend during cut-off.

**Compressor Mode**

Full-load  
Idle  
Cut-off

**Valve Condition**

Open  
Open  
Closed

**Checking**

Remove bolts and pull away from airend. Do not attempt to remove the air-oil pipe. Manually operate check plate. Condensation, a broken spring or oil deposits may cause it to stick open or shut.



## 11.2 Combination (Thermostatic) Valve

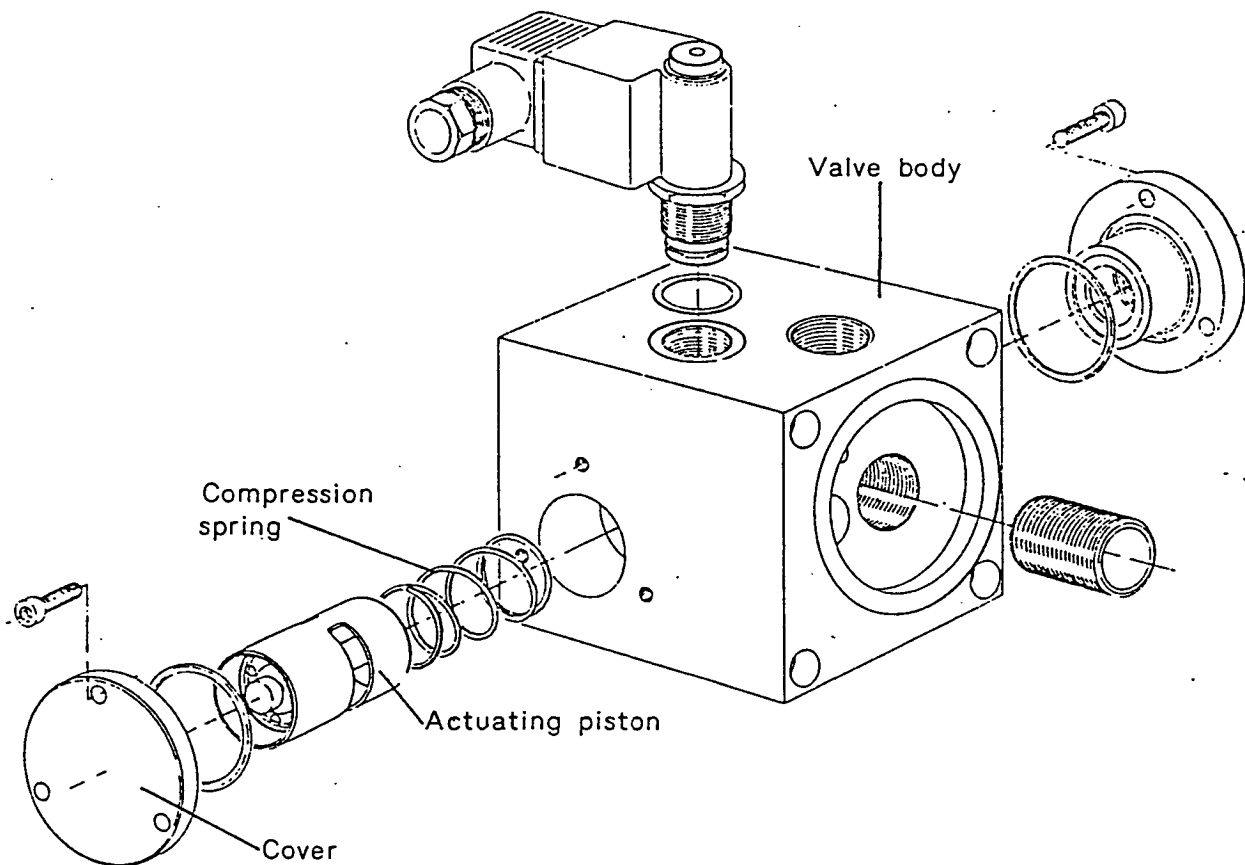

### Function

To regulate flow of oil into oil cooler, thus maintaining proper oil temperature. This valve directs oil into the cooler, or by-passes the cooler to send oil directly back to the airend, as necessary.

**Checking thermostatic operating features of the working element**

Start compressor after allowing it to cool. If thermostatic valve is operating correctly, there should be a sharp increase in the temperature of the cooling exhaust air when the unit reaches operating temperature as the valve directs warm oil through the cooler. If no such increase occurs, or machine runs hotter than normal (greater than 180° F), then remove the actuating piston from the valve assembly. Apply heat to the end of the working element as shown:

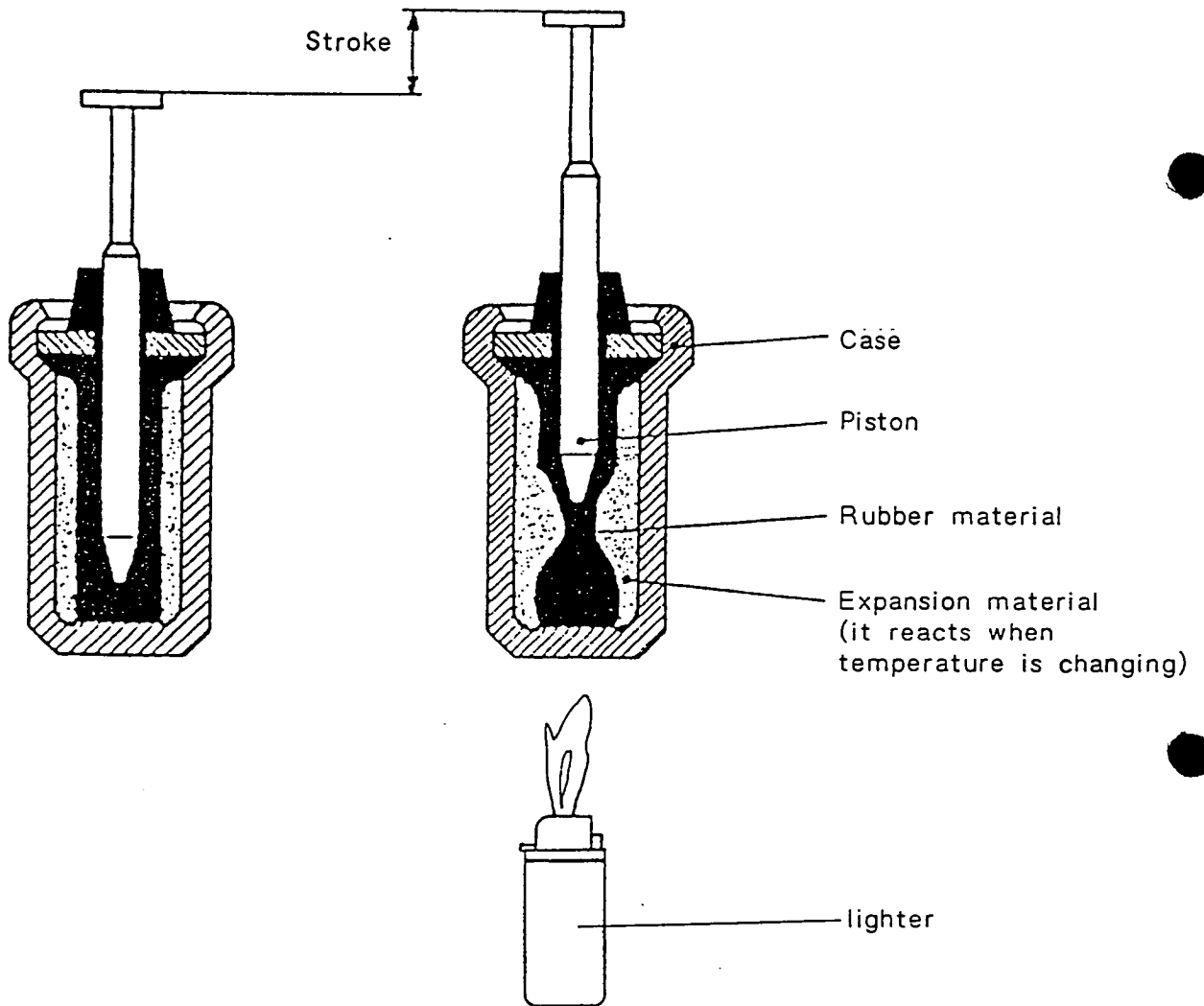

Position: oil is cold

Position: operating temperature is reached

The working element should move outward in the direction indicated. Replace the actuating piston if the element does not move.

**11.3 Control Valve**

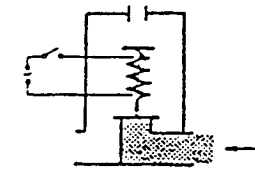

Deenergized closed:  
(currentless)  
when compressor is  
running off-load or is  
cut-off (WYE-time)

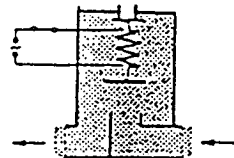
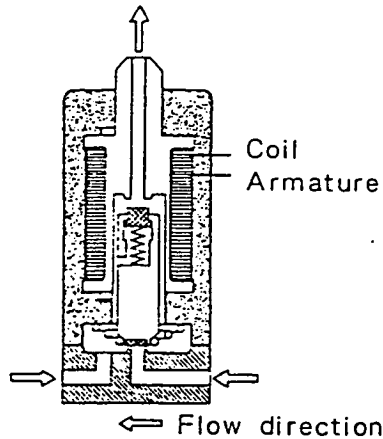

Energized opened:  
when compressor is  
running on-load  
(Delta-time)

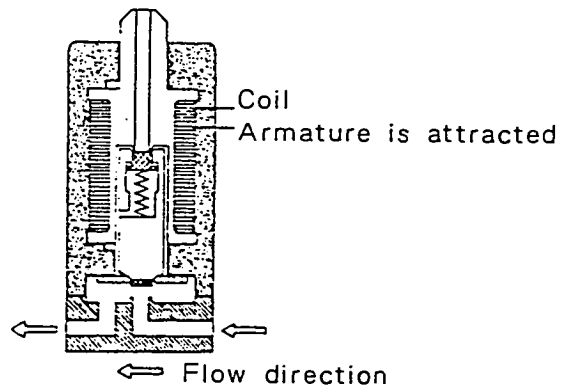

**Function**

This valve is activated by a solenoid coil. It controls the operation of the vent valve and the inlet valve. When the control valve is open, the vent valve is closed and the inlet valve is open. When the control valve is closed, the vent valve is open and the inlet valve is closed.

**Compressor Mode**

Full-load  
Idle (WYE-time,  
or released start up time)  
Cut-off

**Valve Condition**

Open  
Closed  
  
Closed

**Checking**

The coil operates on 110 V AC, so it may be checked with power from any standard outlet. Disconnect leads to the control box and connect outside power. Coil should energize and operate with an audible click. If coil operates with external power, but valve does not operate when machine runs, then check for power in leads from pressure switch. Make sure that the machine is running at full-load when checking for power from pressure switch. If coil operates, and is receiving power from the pressure switch at full-load, but valve still does not function properly, then check control lines for blockage.

BS/CS 04/03.86

**11.4 Inlet Valve**

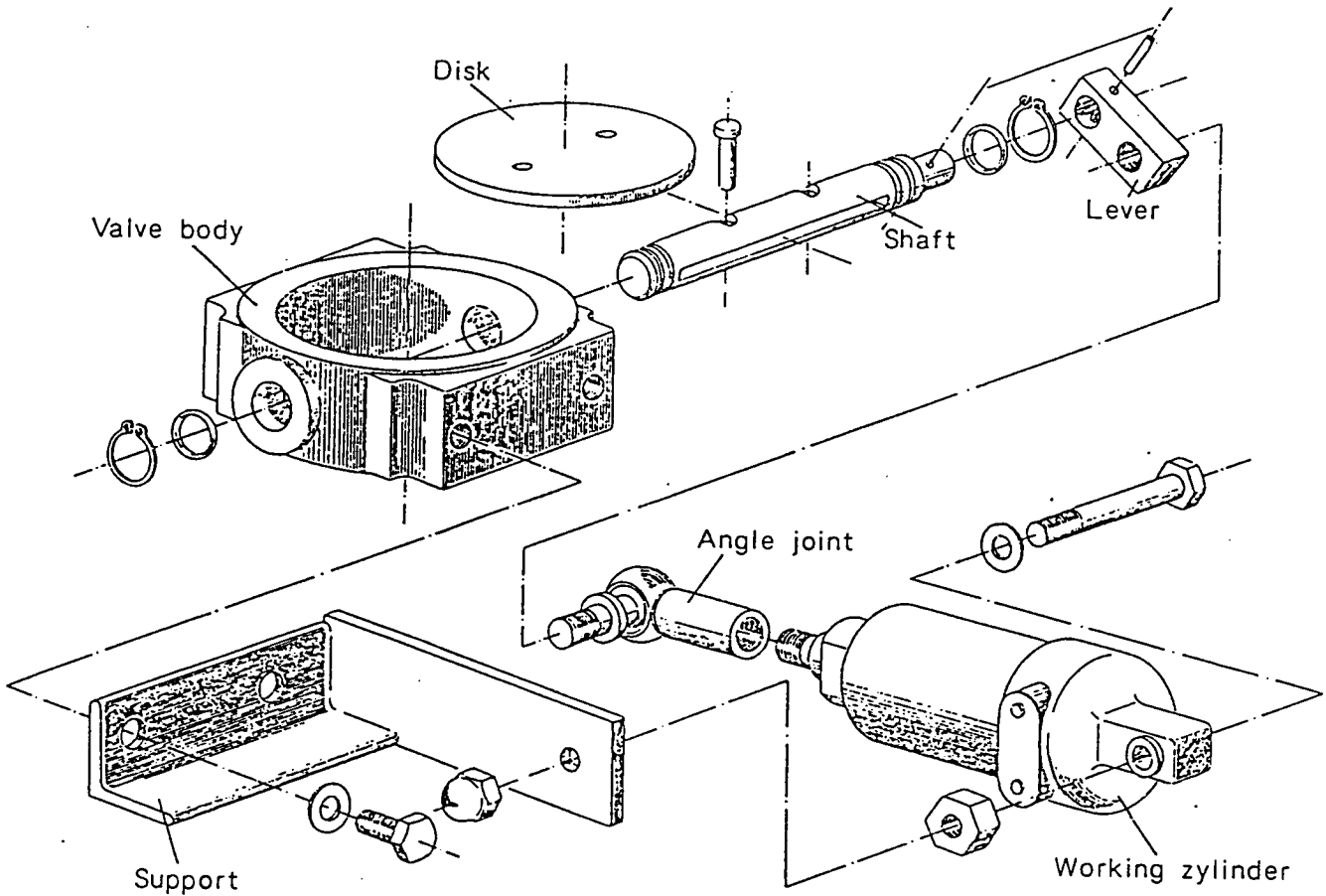

**Function**

To control the flow of air into the aircend. There is a hole in the valve plate to allow some air to enter the aircend when the inlet valve is closed. This hole is just big enough to allow adequate idle pressure for proper oil circulation.

**Compressor Mode**

Full-load  
Idle (WYE-time,  
or released start up time)  
Cut-off

**Valve Condition**

Open  
Closed (but idling hole open)  
Closed

**Checking**

- Pull on the lever that connects the working cylinder to the valve plate, i.e. manually open the inlet valve. It should close when released. If it does not close, or there is no resistance, then the working element spring is defective.
- Run the machine at full load to build up system pressure. Pour soapy water on working cylinder. Bubbles indicate an air leak. Replace entire working cylinder if any leakage is indicated.
- Disconnect valve plate linkage and manually rotate valve plate. It should rotate 360° freely. If it does not then the valve plate is defective.

BS/CS 04/03.86

**11.5 Minimum pressure check valve**

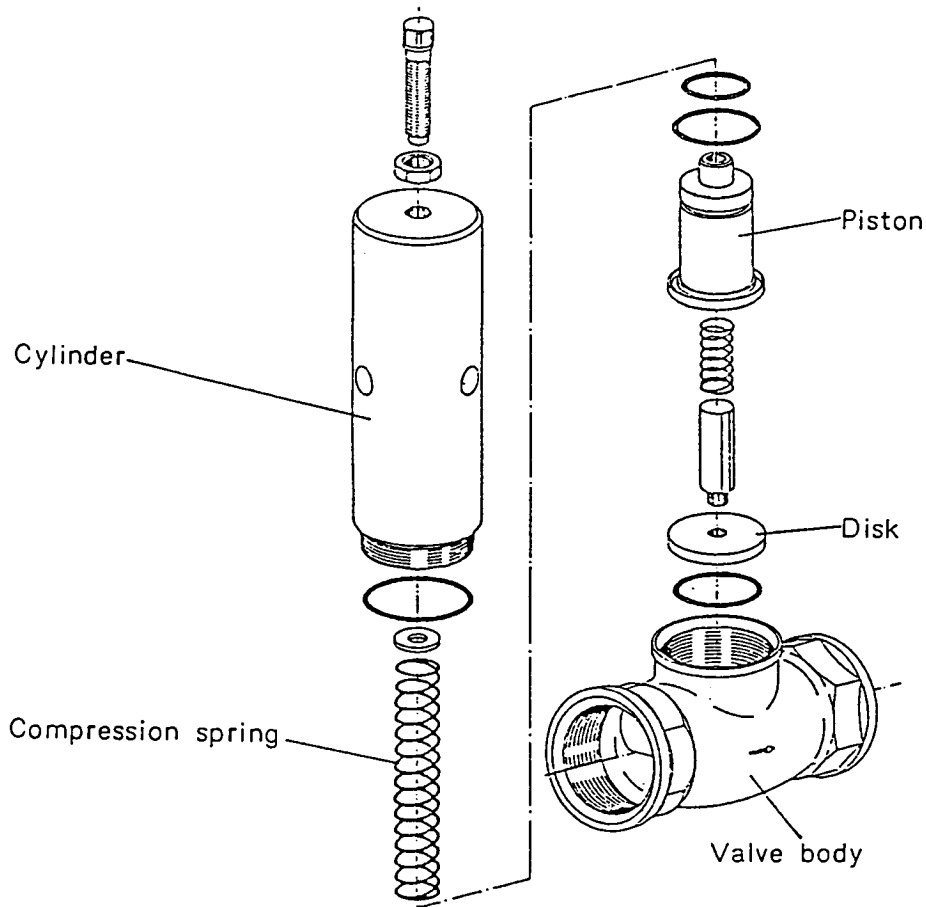

**Function**

- **Minimum Pressure:**  
Allows compressor to build up sufficient pressure for adequate oil circulation before releasing air to the receiver.
- **Check Funktion:**  
Prevents backflow of air through the unit.

**Compressor Mode**

Full-load  
Idle (WYE-time,  
or released start up time)  
Cut-off

**Valve Condition**

Open  
Closed  
  
Closed

**Checking**

- **Minimum Pressure:**  
Start the unit and watch the separator tank pressure and the instrument panel readings. The separator tank pressure should go to about 60 psi before any pressure is indicated on the instrument panel. Be sure that the panel gauge shows no pressure before attempting this test.
- **Check Funktion:**  
Isolate machine and shut it off at maximum pressure. If the valve is not operating then the instrument panel gauge will show a rapid loss of pressure.

BS/CS 04/03.86

**11.6 Oil stop valve**

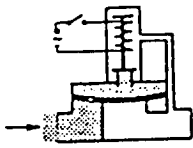

Deenergized closed:  
(currentless)  
when compressor is  
switched off.

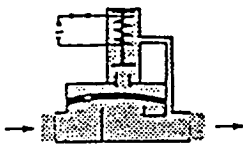
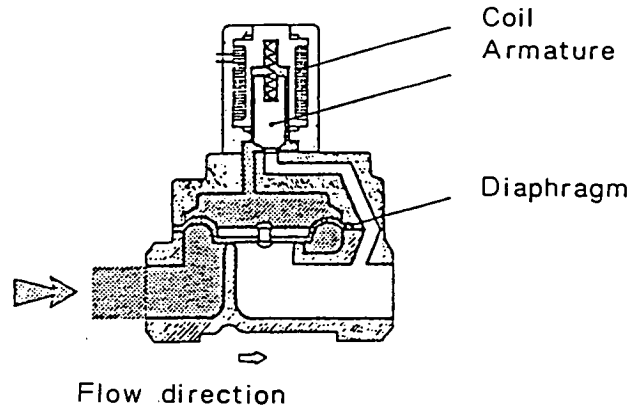

Energized opened:  
when compressor is  
running off load or on  
load.

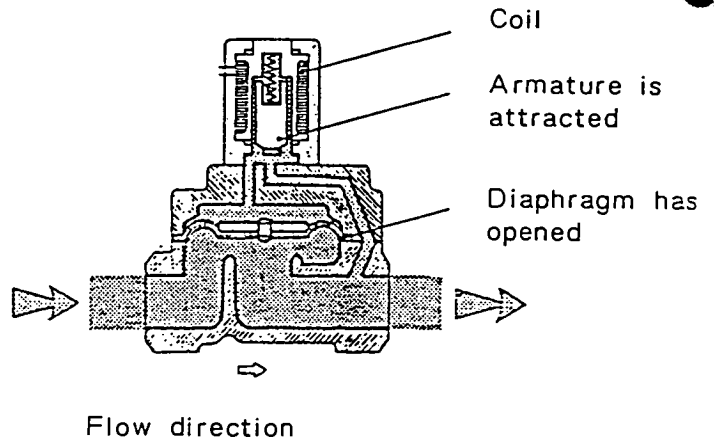

**Function**

Controls flow of oil to the aircend. This valve is activated by a solenoid coil and should always be open when the motor is running. It closes only when the unit shuts off to prevent oil from flooding the aircend.

Compressor Mode	Valve Condition
Full-load	Open
Idle (WYE-time, or released start up time)	Open
Cut-off	Closed

**Checking**

- Be sure to always allow unit to complete one full-load/idle sequence before shutting the machine off. Avoid shutting off unit under full load. Allow unit to idle first if possible.
- Coil activates on 110 V AC. It may be tested with power from any standard outlet. To test coil disconnect leads from the No. 1 Motor Starter and apply power from external source. Coil should activate with an audible click.
- Check for power from No. 1 Motor Starter leads with motor running. If there is no power when motor is running then the starter may be defective.
- If coil activates, and there is power in the leads from the motor starter with the motor running, but the valve still does not operate, then check the diaphragm for rupture or blockage.

**11.7 Vent valve (Discharge valve)**

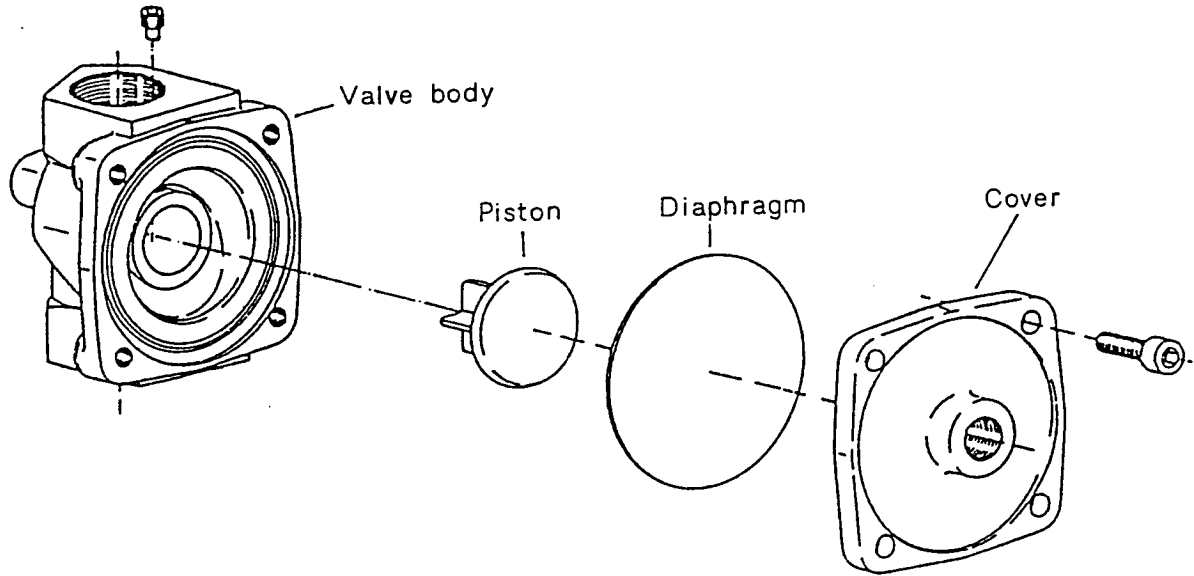

**Function**

To discharge the system pressure during idle and cut-off. It is necessary to discharge pressure during idle to reduce motor load, thus saving energy. The system must be discharged when shut off because starting the compressor against pressure will damage the motor.

**Compressor Mode**

Full-load  
Idle (WYE-time,  
or released start up time)  
Cut-off

**Valve Condition**

Closed  
Open  
Open

**Checking**

- Close ball cock valve in the discharge line.
- Start unit, allow to idle, and shut off immediately.
- If the vent valve diaphragm is defective the inlet valve will operate. Replace the diaphragm if it is defective.

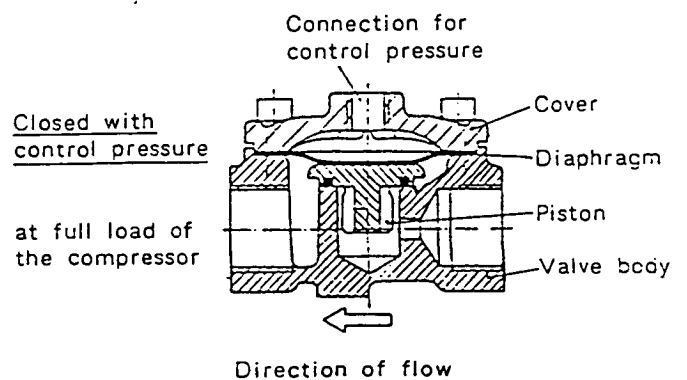
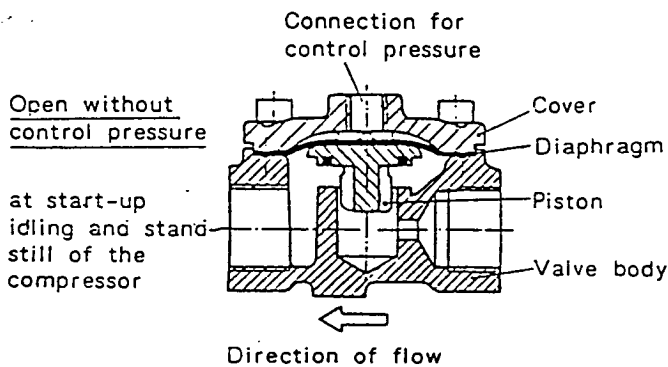

BS/CS 04/03.86