



Ingersoll-Rand

7/120, 9/110, 10/105, 14/85

7/170, 10/125, 14/115

OPERATION AND MAINTENANCE MANUAL

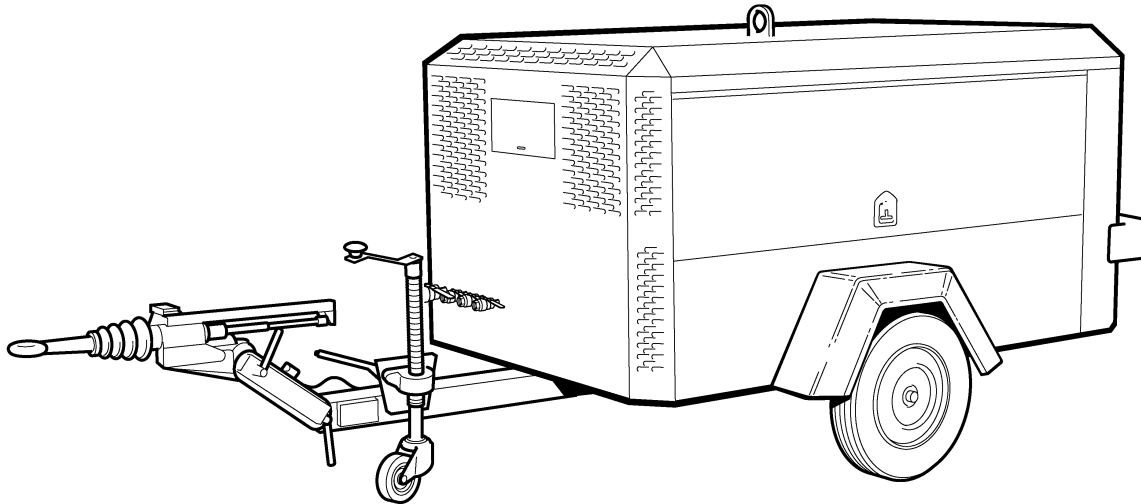
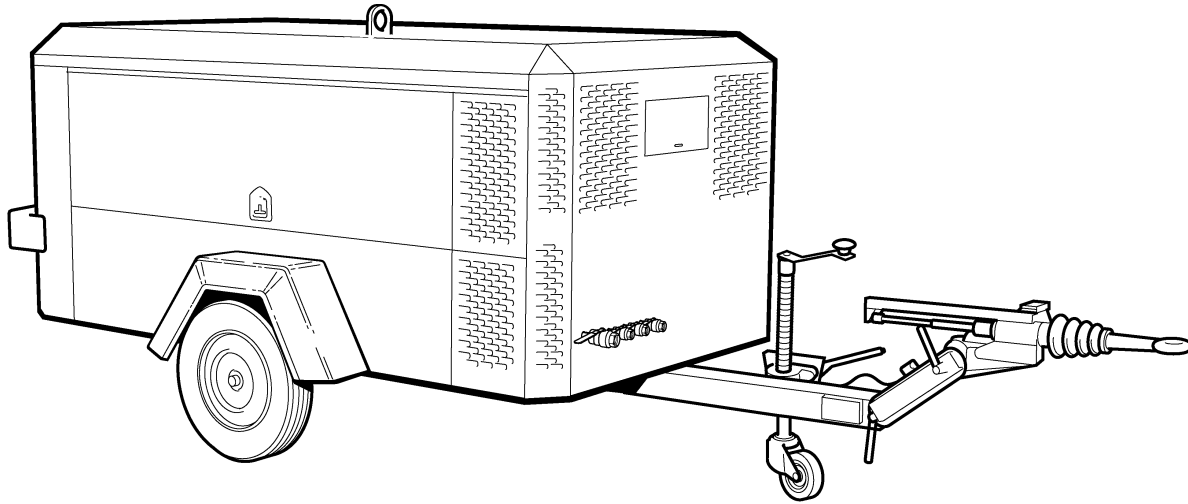

This manual contains important safety information and must be made available to personnel who operate and maintain this machine.

7/120 9/110
10/105 14/85
7/170 10/125 14/115

SERIAL No : 320001 ->

C.C.N. : 22191225 GB
DATE : SEPTEMBER 2003

Machine models represented in this manual may be used in various locations world-wide. Machines sold and shipped into European Union Territories require that the machine display the EC Mark and conform to various directives. In such cases, the design specification of this machine has been certified as complying with EC directives. Any modification to any part is absolutely prohibited and would result in the CE Certification and marking being rendered invalid. A declaration of that conformity follows:

DECLARATION OF CONFORMITY WITH EC DIRECTIVES



98/37/EC, 93/68/EEC, 89/336/EEC

We

Ingersoll-Rand Company
P.O. Box 868
501 Sanford Avenue
Mocksville, North Carolina 27028

Represented in EC by:

Ingersoll-Rand Company Limited
Swan Lane
Hindley Green
Wigan WN2 4EZ
United Kingdom

Declare that, under our sole responsibility for manufacture and supply, the product(s)

**7/120 (P425AWIR) 9/110 (XP375AWIR) 10/105 (HP375AWIR)
14/85 (VHP300AWIR)**

to which this declaration relates, is (are) in conformity with the provisions of the above directives using the following principal standards

EN29001 : EN292, EN60204-1, EN1012-1, PN8NTC2, EN50081, EN50082

Issued at Mocksville on
1-1-2003

Issued at Hindley Green on
1-1-2003

Ric Lunsford
Manager of quality control

Harry Seddon
Quality assurance manager

CONFORMITY WITH NOISE DIRECTIVE 2000/14/EC

Ingersoll-Rand Company Limited declare that the following Portable Compressors have been manufactured in conformity with the directive as shown

Directive	Machine Type	kW	Mean measured value	Guaranteed Level	Notified body
2000/14/EC Annex VI Part I	14/85WIR	93	100.2 LWA	101 LWA	A V Technology Stockport UK Nr 1067
	10/105WIR				
	9/110WIR				
	7/120WIR				

Issued at Mocksville, NC
1st Declaration January 11, 2003

Ric Lunsford
Manager of quality control

EC Pressure Equipment Directive and Related Regulations

We declare that this product has been assessed according to the Pressure Equipment Directive (97/23/EC) and, in accordance with the terms of this Directive, has been excluded from the scope of this Directive. It may carry "CE" marking in compliance with other applicable EC Directives.

Machine models represented in this manual may be used in various locations world-wide. Machines sold and shipped into European Union Territories require that the machine display the EC Mark and conform to various directives. In such cases, the design specification of this machine has been certified as complying with EC directives. Any modification to any part is absolutely prohibited and would result in the CE Certification and marking being rendered invalid. A declaration of that conformity follows:

DECLARATION OF CONFORMITY WITH EC DIRECTIVES



98/37/EC, 93/68/EEC, 89/336/EEC

We

Ingersoll-Rand Company
P.O. Box 868
501 Sanford Avenue
Mocksville, North Carolina 27028

Represented in EC by:

Ingersoll-Rand Company Limited
Swan Lane
Hindley Green
Wigan WN2 4EZ
United Kingdom

Declare that, under our sole responsibility for manufacture and supply, the product(s)

7/170 (P600WIR) 10/125 (HP450WIR) 14/115 (VHP400WIR)

to which this declaration relates, is (are) in conformity with the provisions of the above directives using the following principal standards

EN29001 : EN292, EN60204-1, EN1012-1, PN8NTC2, EN50081, EN50082

Issued at Mocksville on
1-1-2003

Issued at Hindley Green on
1-1-2003

Ric Lunsford
Manager of quality control

Harry Seddon
Quality assurance manager

CONFORMITY WITH NOISE DIRECTIVE 2000/14/EC

Ingersoll-Rand Company Limited declare that the following Portable Compressors have been manufactured in conformity with the directive as shown

Directive	Machine		Mean measured value	Guaranteed Level	Notified body
	Type	kW			
2000/14/EC Annex VI Part I	14/115	126.5	100.2 LWA	101 LWA	A V Technology Stockport UK Nr 1067
	10/125				
	7/170				

Issued at Mocksville, NC
1st Declaration January 11, 2003

Ric Lunsford
Manager of quality control

EC Pressure Equipment Directive and Related Regulations

We declare that this product has been assessed according to the Pressure Equipment Directive (97/23/EC) and, in accordance with the terms of this Directive, has been excluded from the scope of this Directive. It may carry "CE" marking in compliance with other applicable EC Directives.

1	CONTENTS
2	FOREWORD
3	WARRANTY
9	DECALS
13	SAFETY
16	GENERAL INFORMATION Dimensions Data
21	OPERATING INSTRUCTIONS Commissioning Prior to starting Starting Stopping Emergency stopping Re-starting Monitoring during operation Decommissioning
29	ENGINE INSTRUCTION MANUAL
46	MAINTENANCE Routine maintenance Lubrication Speed & pressure regulation Torque settings table Compressor lubrication
58	MACHINE SYSTEMS Electrical system Piping & instrumentation system

61	SERVICE TOOLS
65	FAULT FINDING
67	OPTIONS
70	PARTS ORDERING

ABBREVIATIONS & SYMBOLS

####	Contact Ingersoll-Rand for serial number
->####	Up to Serial No.
####->	From Serial No.
*	Not illustrated
†	Option
AR	As required
D	Germany
DK	Denmark
E	Spain
F	France
GB	Great Britain
HA	High ambient machine
I	Italy
N	Norway
NL	Netherlands
P	Portugal
S	Sweden
SF	Finland
F.H.R.G.	Fixed height running gear
V.H.R.G.	Variable height running gear

FOREWORD

The contents of this manual are considered to be proprietary and confidential to Ingersoll-Rand and should not be reproduced without the prior written permission of Ingersoll-Rand.

Nothing contained in this document is intended to extend any promise, warranty or representation, expressed or implied, regarding the Ingersoll-Rand products described herein. Any such warranties or other terms and conditions of sale of products shall be in accordance with the standard terms and conditions of sale for such products, which are available upon request.

This manual contains instructions and technical data to cover all routine operation and scheduled maintenance tasks by operation and maintenance staff. Major overhauls are outside the scope of this manual and should be referred to an authorised Ingersoll-Rand service department.

The design specification of this machine has been certified as complying with EC directives. As a result:

(a) Any machine modifications are strictly prohibited, and will invalidate EC certification.

(b) A unique specification for USA/Canada is adopted and tailored to the territory.

All components, accessories, pipes and connectors added to the compressed air system should be:

- . of good quality, procured from a reputable manufacturer and, wherever possible, be of a type approved by Ingersoll-Rand.
- . clearly rated for a pressure at least equal to the machine maximum allowable working pressure.
- . compatible with the compressor lubricant/coolant.
- . accompanied with instructions for safe installation, operation and maintenance.

Details of approved equipment are available from Ingersoll-Rand Service departments.

The use of repair parts / lubricants / fluids other than those included within the Ingersoll-Rand approved parts list may create hazardous conditions over which Ingersoll-Rand has no control. Therefore Ingersoll-Rand cannot be held responsible for equipment in which non-approved repair parts are installed.

Ingersoll-Rand reserves the right to make changes and improvements to products without notice and without incurring any obligation to make such changes or add such improvements to products sold previously.

The intended uses of this machine are outlined below and examples of unapproved usage are also given, however Ingersoll-Rand cannot anticipate every application or work situation that may arise.

IF IN DOUBT CONSULT SUPERVISION.

This machine has been designed and supplied for use only in the following specified conditions and applications:

- . Compression of normal ambient air containing no known or detectable additional gases, vapours, or particles
- . Operation within the ambient temperature range specified in the *GENERAL INFORMATION* section of this manual.

UNITS MANUFACTURED IN NORTH AMERICA: Generation of electricity at 120V (1ph) at 60 Hertz.

UNITS MANUFACTURED IN EUROPE: Generation of electricity not applicable.

The use of the machine in any of the situation types listed in table 1:-

- a) Is not approved by Ingersoll-Rand,**
- b) May impair the safety of users and other persons, and**
- c) May prejudice any claims made against Ingersoll-Rand.**

TABLE 1
Use of the machine to produce compressed air for: a) direct human consumption b) indirect human consumption, without suitable filtration and purity checks.
Use of the machine outside the ambient temperature range specified in the <i>GENERAL INFORMATION SECTION</i> of this manual.
This machine is not intended and must not be used in potentially explosive atmospheres, including situations where flammable gases or vapours may be present.
Use of the machine fitted with non Ingersoll-Rand approved components / lubricants / fluids.
Use of the machine with safety or control components missing or disabled.
Use of the machine for storage or transportation of materials inside or on the enclosure except when contained within the toolbox.
GENERATOR
Use of the generator to supply load(s) greater than those specified.
Use of unsafe or unserviceable electrical equipment connected to the generator.
Use of electrical equipment: (a) Having incorrect voltage and/or frequency ratings. (b) Containing computer equipment and/or similar electronics.

The company accepts no responsibility for errors in translation of this manual from the original English version.

© COPYRIGHT 2003
INGERSOLL-RAND COMPANY

WARRANTY

Ingersoll-Rand, through its distributor, warrants that each item of equipment manufactured by it and delivered hereunder to the initial user will be free of defects in material and workmanship.

With respect to the following types of equipment, the warranty period enumerated below will apply.

- A. **Aftercoolers** – The earlier of nine (9) months from date of shipment to or six (6) months from start up by initial user.
- B. **Portable Compressors, Portable Generator Sets (GENSET), Portable Light Towers and Air Dyers** – The earlier of twelve (12) months from shipment to or the accumulation of 2,000 hours of service by the initial user.
- C. **Portable Compressor Air Ends** – The earlier of twenty-four (24) months from shipment to or the accumulation of 4,000 hours of service by the initial user. For Air Ends, the warranty against defects will include replacement of the complete Air End, provided the original Air End, is returned assembled and unopened.
- C.1 **Portable Compressor Airend Limited Optional Warranty** – The earlier of sixty (60) months from shipment to or the accumulation of 10,000 hours of service. The optional warranty is limited to defects in rotors, housings, bearings and gears and provided all the following conditions are met:
 - The original airend is returned assembled and unopened.
 - Continued use of genuine Ingersoll-Rand parts, fluids, oils and filters.
 - Maintenance is performed at prescribed intervals.
- D. **Genset Generators** – The earlier of twenty-four (24) months from shipment to or the accumulation of 4,000 hours of service by the initial user.
- E. **Portable Light Tower Generators** – The earlier of twelve (12) months from shipment to or the accumulation of 2,000 hours of service by the initial user. Light Source model only, the earlier of twenty-four (24) months from shipment to or the accumulation of 4,000 hours of service.
- F. **Ingersoll-Rand Engines** – The earlier of twenty-four (24) months from shipment to or the accumulation of 4,000 hours of service.

- G. **Ingersoll-Rand Platinum Drive Train Warranty (Optional)** – Platinum drive train pertains to the Ingersoll-Rand Engine and Airend combination. The earlier of sixty (60) months from shipment to, or the accumulation of 10,000 hours of service. The starter, alternator, fuel injection system and all electrical components are excluded from the extended warranty. The airend seal and drive coupling are included in the warranty (air-end drive belts are not included). The optional warranty is automatically available when meeting the following conditions:

The original airend is returned assembled and unopened.

Continued use of genuine Ingersoll-Rand parts, fluids, oil and filters.

Maintenance is performed at prescribed intervals.

It is the obligation of the user to provide verification that these conditions have been satisfied when submitting warranty claims.

- H. **Spare Parts** – Six (6) months from date of installation

Ingersoll-Rand will provide a new part or repaired part, at its election, in place of any part which is found upon its inspection to be defective in material and workmanship during the period prescribed above. Such part will be repaired or replaced without charge to the initial user during normal working hours at the place of business of an Ingersoll-Rand distributor authorized to sell the type of equipment involved or other establishment authorized by Ingersoll – Rand. User must present proof of purchase at the time of exercising warranty.

The above warranty does not apply to failures occurring as a result of abuse; misuse, negligent repairs, corrosion, erosion and normal wear and tear, alterations or modifications made to the product without express written consent of Ingersoll-Rand; or failure to follow the recommended operating practices and maintenance procedures as provided in the product's operating and maintenance publications.

Accessories or equipment furnished by Ingersoll-Rand, but manufactured by others, including, but not limited to, engines, tires, batteries, engine electrical equipment, hydraulic transmissions, carriers, shall carry whatever warranty the manufacturers have conveyed to Ingersoll-Rand and which can be passed on to the initial user.

THIS WARRANTY IS IN LIEU OF ALL OTHER WARRANTIES EXPRESSED OR IMPLIED, (EXCEPT THAT OF TITLE), AND THERE ARE NO WARRANTIES OF MERCHANTABILITY OR OF FITNESS FOR A PARTICULAR PURPOSE.

GENERAL WARRANTY INFORMATION

GENERAL WARRANTY			Extended Coverage
Portable Compressor	Package	1 year/2000 hrs	
	Airend	2 yrs/4000 hrs	5 yrs/10,000 hrs Limited warranty, major components (refer to operator's manual).

Portable Genset 8kW, 11KW, 20KVA thru 575KVA	Package	1 yr/2000 hrs	None
	Generator	2 yrs/4000 hrs	None

Portable Genset 3.5KW thru 7.0KW and 10KW	Package	1 yr/2000 hrs (parts only)	None
	Generator	1 yrs/2000 hrs (parts only)	None

Light Tower	Package	1 yr/2000 hrs	
	Generator	1 yr/2000 hrs	2 years/4000 hours, for Lightsource introduced 8/16/99.

ENGINES			
	Months	Hours	Extended Coverage
CATERPILLAR	12	unlimited	Available at dealer
CUMMINS	24	2000	Major components 3 yrs/10,000 hrs Available at dealer
JOHN DEERE (in compressors)	24	2000	5 yrs/5000 hrs using OEM fluids and filters with \$250 deductible
(in generators as of 1/1/01)	24	2000	2 yrs/4000 hrs using IR fluids and filters
DEUTZ	24	2000	Available at dealer
INGERSOLL-RAND	24	4000	5 yrs/10,000 hrs when using genuine Ingersoll-Rand fluids and parts. Refer to operator's manual.
KUBOTA (North America only)	24	2000	Major components 36 mo/3000 hrs (parts only)
(Western Europe & Oceania)	24	2000	None
(Central & South America, Asia, Middle East & Africa)	12	1000	None
MITSUBISHI	24	2000	2 yrs/4000 hrs using IR fluids and filters
VOLVO	24	2000	2 yrs/4000 hrs using IR fluids and filters
HONDA	12	unlimited	None
VANGUARD	24	unlimited	None

PARTS			
	Months	Hours	Coverage
Ingersoll-Rand	6	No Limit	Parts Only

AIREND EXCHANGE			
	Months	Hours	Extended Coverage
Airend	12	2000	2 yrs/4000 hrs – available from IR.

Note: Actual warranty times may change. Consult the manufacturer's warranty policy as shipped with each new product.

Extended Limited Airend Warranty

Ingersoll–Rand Portable Compressor Division is pleased to announce the availability of extended limited airend warranty. Announcement of the extended warranty coincides with the introduction of Pro–Tec™ Compressor Fluid. Pro–Tec™ Compressor Fluid is an amber coloured fluid specially formulated for Portable Compressors and is being provided as the factory filled fluid for all machines except ¹ XHP650/900/1070

All machines have the standard airend warranty, – *The earlier of 24 months from shipment to, or the accumulation of 4000 hours of service by the initial user.*

The warranty against defects will include replacement of the complete Airend, provided the original Airend is returned assembled and unopened.

The optional limited warranty is the earlier of 60 months from shipment to, or the accumulation of 10,000 hours of service. The optional warranty is limited to defects in major components (rotors, housings, gears and bearings), and is automatically available when the following conditions are met:

1. The original airend is returned assembled and unopened.
2. Submissions of proof that Ingersoll–Rand fluid, filters and separators have been used. Refer to the Operation and Parts manual for the correct fluids, filters and separator elements required.
3. Submissions of proof that maintenance intervals have been followed.

WARRANTY	TIME	*BARE AIREND	**AIREND COMPONENTS
STANDARD	2YRS / 4,000HRS	100% PARTS & LABOUR	100% PARTS & LABOUR
OPTIONAL	5YRS / 10,000HRS	100% PARTS & LABOUR	0%

*BARE AIREND – pertains to major airend parts (rotors, housings, gears and bearings).

**AIREND COMPONENTS – pertains to auxiliary attachments to the bare airend (seals, pumps, valves, tubes, hoses, fittings and filter housing).

Pro–Tec™ and XHP505 Compressor Fluids are available from your local Ingersoll–Rand branch or distributor.

For units operating within the USA & Canada, call the Mocksville Product Support Department on 1–800–633–5206

¹ XHP650/900/1070 will continue to use XHP505 and will have the extended warranty when above conditions are met.

WARRANTY REGISTRATION

FOR UNITS SOURCED FROM HINDLEY GREEN, UK

Complete Machine Registration

To initiate the machine warranty, fill out the "Warranty Registration" form 83242 11/99 supplied as part of the machine documentation, keep a copy for your records and mail the original to:

**Ingersoll Rand European Sales Ltd
Portable Power Business
Swan Lane
Hindley Green
Wigan
Lancashire
WN2 4EZ
U.K.**

Attn: Customer Service Department

Note: Completion of this form validates the warranty.

Engine Registration:

I-R powered machines do not require separate engine registration.

Deutz require a separate engine registration form to be completed and mailed direct to their Cologne office. The form is supplied as part of the machine documentation for Deutz powered machines.

Caterpillar, Cummins and Perkins do not require a separate registration form but they stipulate that any new engine should be registered with their local dealer to initiate warranty.

You **MUST** provide proof of the "in-service" date when requesting engine warranty repairs.

Selling Distributor	Servicing Distributor	WARRANTY REGISTRATION
Name _____	Name _____	Owner/User Name _____
Address _____	Address _____	Address _____
City _____	City _____	City _____
County _____	County _____	County _____
State _____	State _____	State _____
Zip code _____	Zip code _____	Zip code _____
Telephone _____	Telephone _____	Telephone _____

Complete the Applicable Blocks

Owner/User Type of Business (check one only)

<input type="checkbox"/> Construction—Heavy (highway, excavation, etc.)	<input type="checkbox"/> Asphalt Contractor	<input type="checkbox"/> Coal Mining	<input type="checkbox"/> Other Mining
<input type="checkbox"/> Construction—Light (carpentry, plumbing, pools, mason, etc.)	<input type="checkbox"/> Government (municipal, state, county, etc.)	<input type="checkbox"/> Quarry	<input type="checkbox"/> Shallow Oil & Gas
<input type="checkbox"/> Rental (rental center, rental fleet, etc.)	<input type="checkbox"/> Building Contractor	<input type="checkbox"/> Water well	<input type="checkbox"/> Utility Company (gas, electric, water, etc.)
<input type="checkbox"/> Industrial (plant use)	<input type="checkbox"/> Other specify _____	<input type="checkbox"/> Exploration	<input type="checkbox"/> Utility Contractor

Model S/N	Unit S/N	Engine S/N	Date delivered
_____	_____	_____	_____
Unit—Hours	Airend S/N	Truck S/N	Truck Engine S/N
_____	_____	_____	_____







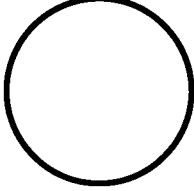
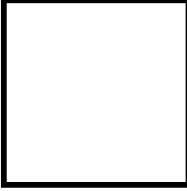
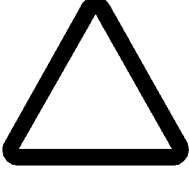

SERVICING DISTRIBUTOR / USER ACKNOWLEDGEMENT

1. The Purchaser has been instructed and/or has read the manual and understands proper preventative maintenance, general operation and safety precautions.
2. The warranty and limitation of liability has been reviewed and understood by the owner/user.
3. In the event that this unit is to be used within a nuclear facility, the owner/user shall notify Ingersoll—Rand of such use so that Ingersoll—Rand may arrange for appropriate nuclear liability protection from the owner—licensee of the facility.
4. Ingersoll—Rand reserves the right to make design changes or modifications of Ingersoll—Rand products at anytime without incurring any obligation to make similar changes or modifications on previously sold units.

DECALS

Look for these signs on machines manufactured in Europe, which point out potential hazards to the safety of you and others. Read and understand thoroughly. Heed warnings and follow instructions. If you do not understand, inform you supervisor.

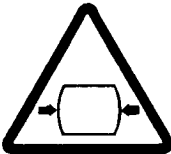
GRAPHIC FORM AND MEANING OF ISO SYMBOLS

		
Prohibition / Mandatory	Information / Instructions	Warning
 <p>WARNING: Electrical shock risk.</p>	 <p>WARNING – Pressurised component or system.</p>	 <p>WARNING – Hot surface.</p>
 <p>WARNING – Pressure control.</p>	 <p>WARNING – Corrosion risk.</p>	 <p>WARNING – Air/gas flow or Air discharge.</p>
 <p>WARNING – Pressurised vessel.</p>	 <p>WARNING – Hot and harmful exhaust gas.</p>	 <p>WARNING – Maintain correct tyre pressure. (Refer to the GENERAL INFORMATION section of this manual).</p>



WARNING – Flammable liquid.



WARNING – Before connecting the tow bar or commencing to tow consult the operation and maintenance manual.

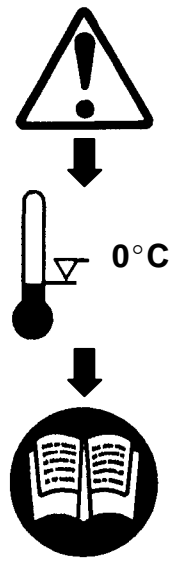

WARNING – For operating temperature below 0°C, consult the operation and maintenance manual.

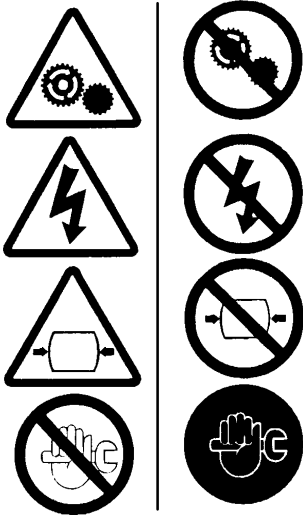

WARNING – Do not undertake any maintenance on this machine until the electrical supply is disconnected and the air pressure is totally relieved.



WARNING – Consult the operation and maintenance manual before commencing any maintenance.



Do not breathe the compressed air from this machine.



Do not remove the Operating and Maintenance manual and manual holder from this machine.



Do not stack.



Do not operate the machine without the guard being fitted.



Do not stand on any service valve or other parts of the pressure system.



Do not operate with the doors or enclosure open.



Do not use fork lift truck from this side.



Do not exceed the trailer speed limit.



No naked lights.



Do not open the service valve before the airhose is attached.



Use fork lift truck from this side only.

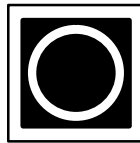

Emergency stop.



Tie down point



Lifting point.



On (power).



Off (power).



Read the Operation and Maintenance manual before operation or maintenance of this machine is undertaken.

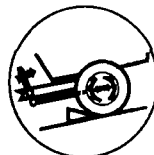

When parking use prop stand, handbrake and wheel chocks.

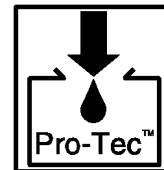

Compressor oil filling

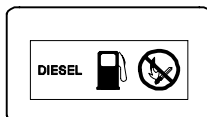

Diesel fuel
No open flame.

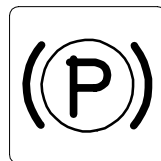

Parking brake.



Rough Service Designation.
Wet Location Operation.

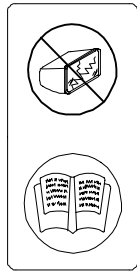

Replace any cracked protective shield.

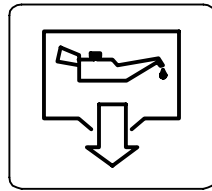

Oil drain.

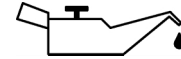

Engine Oil

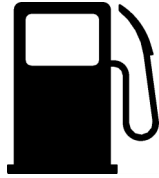

Fuel level/point

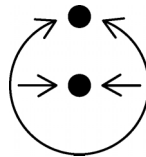

Pressure control



Malfunction

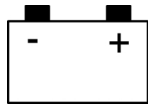

Battery charging condition

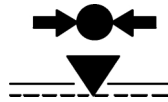

Low pressure

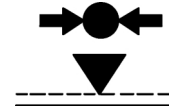

High pressure



Engine malfunction



High compressor temperature



Compressor malfunction



Low engine oil pressure

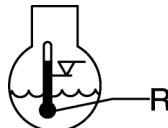

Engine high temperature

SAFETY

WARNINGS

Warnings call attention to instructions which must be followed precisely to avoid injury or death.

CAUTIONS

Cautions call attention to instructions which must be followed precisely to avoid damaging the product, process or its surroundings.

NOTES

Notes are used for supplementary information.

General Information

Never operate unit without first observing all safety warnings and carefully reading the operation and maintenance manual shipped from the factory with this machine.

Ensure that the operator reads and *understands* the decals and consults the manuals before maintenance or operation.

Ensure that the Operation and Maintenance manual, and the manual holder, are not removed permanently from the machine.

Ensure that maintenance personnel are adequately trained, competent and have read the Maintenance Manuals.

Make sure that all protective covers are in place and that the canopy/doors are closed during operation.

The specification of this machine is such that the machine is not suitable for use in flammable gas risk areas. If such an application is required then all local regulations, codes of practice and site rules must be observed. To ensure that the machine can operate in a safe and reliable manner, additional equipment such as gas detection, exhaust spark arrestors, and intake (*shut-off*) valves may be required, dependant on local regulations or the degree of risk involved.

A weekly visual check must be made on all fasteners/fixing screws securing mechanical parts. In particular, safety-related parts such as coupling hitch, drawbar components, road-wheels, and lifting bail should be checked for total security.

All components which are loose, damaged or unserviceable, must be rectified without delay.

Air discharged from this machine may contain carbon monoxide or other contaminants which will cause serious injury or death. Do not breathe this air.

This machine produces loud noise with the doors open or service valve vented. Extended exposure to loud noise can cause hearing loss. Always wear hearing protection when doors are open or service valve is vented.

Never inspect or service unit without first disconnecting battery cable(s) to prevent accidental starting.

Do not use petroleum products (solvents or fuels) under high pressure as this can penetrate the skin and result in serious illness. wear eye protection while cleaning unit with compressed air to prevent debris from injuring eye(s).

Rotating fan blade can cause serious injury. Do not operate without guard in place.

Use care to avoid contacting hot surfaces (engine exhaust manifold and piping, air receiver and air discharge piping, etc.).

Ether is an extremely volatile, highly inflammable gas. When it is specified as a starting aid, use sparingly. **DO NOT USE ETHER IF THE MACHINE HAS GLOW PLUGS OR INLET HEATER STARTING AIDS OR ENGINE DAMAGE WILL RESULT.**

Never operate unit with guards, covers or screens removed. Keep hands, hair, clothing, tools, blow gun tips, etc. well away from moving parts.

Compressed air

Compressed air can be dangerous if incorrectly handled. Before doing any work on the unit, ensure that all pressure is vented from the system and that the machine cannot be started accidentally.

Ensure that the machine is operating at the rated pressure and that the rated pressure is known to all relevant personnel.

All air pressure equipment installed in or connected to the machine must have safe working pressure ratings of at least the machine rated pressure.

If more than one compressor is connected to one common downstream plant, effective check valves and isolation valves must be fitted and controlled by work procedures, so that one machine cannot accidentally be pressurised / over pressurised by another.

Compressed air must not be used for a direct feed to any form of breathing apparatus or mask.

High Pressure Air can cause serious injury or death. Relieve pressure before removing filler plugs/caps, fittings or covers.

Air pressure can remain trapped in air supply line which can result in serious injury or death. Always carefully vent air supply line at tool or vent valve before performing any service.

The discharged air contains a very small percentage of compressor lubricating oil and care should be taken to ensure that downstream equipment is compatible.

If the discharged air is to be ultimately released into a confined space, adequate ventilation must be provided.

When using compressed air always use appropriate personal protective equipment.

All pressure containing parts, especially flexible hoses and their couplings, must be regularly inspected, be free from defects and be replaced according to the Manual instructions.

Avoid bodily contact with compressed air.

The safety valve located in the separator tank must be checked periodically for correct operation.

Whenever the machine is stopped, air will flow back into the compressor system from devices or systems downstream of the machine unless the service valve is closed. Install a check valve at the machine service valve to prevent reverse flow in the event of an unexpected shutdown when the service valve is open.

Disconnected air hoses whip and can cause serious injury or death. Always attach a safety flow restrictor to each hose at the source of supply or branch line in accordance with OSHA Regulation 29CFR Section 1926.302(b).

Never allow the unit to sit stopped with pressure in the receiver-separator system.

Materials

The following substances *may* be produced during the operation of this machine:

- . brake lining dust
- . engine exhaust fumes

AVOID INHALATION

Ensure that adequate ventilation of the cooling system and exhaust gases is maintained at all times.

The following substances are used in the manufacture of this machine and *may* be hazardous to health if used incorrectly:

- . anti-freeze
- . compressor lubricant
- . engine lubricant
- . preservative grease
- . rust preventative
- . diesel fuel
- . battery electrolyte

AVOID INGESTION, SKIN CONTACT AND INHALATION OF FUMES

Should compressor lubricant come into contact with the eyes, then irrigate with water for at least 5 minutes.

Should compressor lubricant come into contact with the skin, then wash off immediately.

Consult a physician if large amounts of compressor lubricant are ingested.

Consult a physician if compressor lubricant is inhaled.

Never give fluids or induce vomiting if the patient is unconscious or having convulsions.

Safety data sheets for compressor and engine lubricants should be obtained from the lubricant supplier.

Never operate the engine of this machine inside a building without adequate ventilation. Avoid breathing exhaust fumes when working on or near the machine.

This machine may include such materials as oil, diesel fuel, antifreeze, brake fluid, oil/air filters and batteries which may require proper disposal when performing maintenance and service tasks. Contact local authorities for proper disposal of these materials.

Battery

A battery contains sulphuric acid and can give off gases which are corrosive and potentially explosive. Avoid contact with skin, eyes and clothing. In case of contact, flush area immediately with water.

DO NOT ATTEMPT TO SLAVE START A FROZEN BATTERY SINCE THIS MAY CAUSE IT TO EXPLODE.

Exercise extreme caution when using booster battery. To jump battery, connect ends of one booster cable to the positive (+) terminal of each battery. Connect one end of other cable to the negative (-) terminal of the booster battery and other end to a ground connection away from dead battery (to avoid a spark occurring near any explosive gases that may be present). After starting unit, always disconnect cables in reverse order.

Radiator

Hot engine coolant and steam can cause injury. Ensure that the radiator filler cap is removed with due care and attention.

Do not remove the pressure cap from a HOT radiator. Allow radiator to cool down before removing pressure cap.

Transport

When loading or transporting machines ensure that the specified lifting and tie down points are used.

When loading or transporting machines ensure that the towing vehicle, its size, weight, towing hitch and electrical supply are all suitable to provide safe and stable towing at speeds either, up to the legal maximum for the country in which it is being towed or, as specified for the machine model if lower than the legal maximum.

Ensure that the maximum trailer weight does not exceed the maximum gross weight of the machine (by limiting the equipment load), limited by the capacity of the running gear.

Note:

Gross mass (on data plate) is for the basic machine and fuel only, excluding any fitted options, tools, equipment and foreign materials.

Before towing the machine, ensure that:-

- . the tyres and towing hitch are in a serviceable condition.
- . the canopy is secure.
- . all ancillary equipment is stored in a safe and secure manner.
- . the brakes and lights are functioning correctly and meet necessary road traffic requirements.
- . break-away cables/safety chains are connected to the towing vehicle.

The machine must be towed in a level attitude in order to maintain correct handling, braking and lighting functions. This can be achieved by correct selection and adjustment of the vehicle towing hitch and, on variable height running gear, adjustment of the drawbar.

To ensure full braking efficiency, the front (towing eye) section must always be set level.

When adjusting variable height running gear:-

Ensure front (towing eye) section is set level

When raising towing eye, set rear joint first, then front joint.

When lowering towing eye, set front joint first, then rear joint.

After setting, fully tighten each joint by hand and then tighten further to the next pin. Refit the pin.

When parking always use the handbrake and, if necessary, suitable wheel chocks.

Make sure wheels, tyres and tow bar connectors are in safe operating condition and tow bar is properly connected before towing.

Safety chains / connections and their adjustment

The legal requirements for the joint operation of the breakaway cable and safety chains are as yet unidentified by 71/320/EEC or UK regulations. Consequently we offer the following advice / instructions.

Where brakes only are fitted:

- a) Ensure that the breakaway cable is securely coupled to the handbrake lever and also to a substantial point on the towing vehicle.
- b) Ensure that the effective cable length is as short as possible, whilst still allowing enough slackness for the trailer to articulate without the handbrake being applied.

Where brakes and safety chains are fitted:

- a) Loop the chains onto the towing vehicle using the towing vehicle hitch as an anchorage point, or any other point of similar strength.
- b) Ensure that the effective chain length is as short as possible whilst still allowing normal articulation of the trailer and effective operation of the breakaway cable.

Where safety chains only are fitted:

- a) Loop the chains onto the towing vehicle using the towing vehicle hitch as an anchorage point, or any other point of similar strength.
- b) When adjusting the safety chains there should be sufficient free length in the chains to allow normal articulation, whilst also being short enough to prevent the towbar from touching the ground in the event of an accidental separation of the towing vehicle from the trailer.

7/120 9/110 10/105 14/85
P425AWIR XP375AWIR HP375AWIR
VHP300AWIR

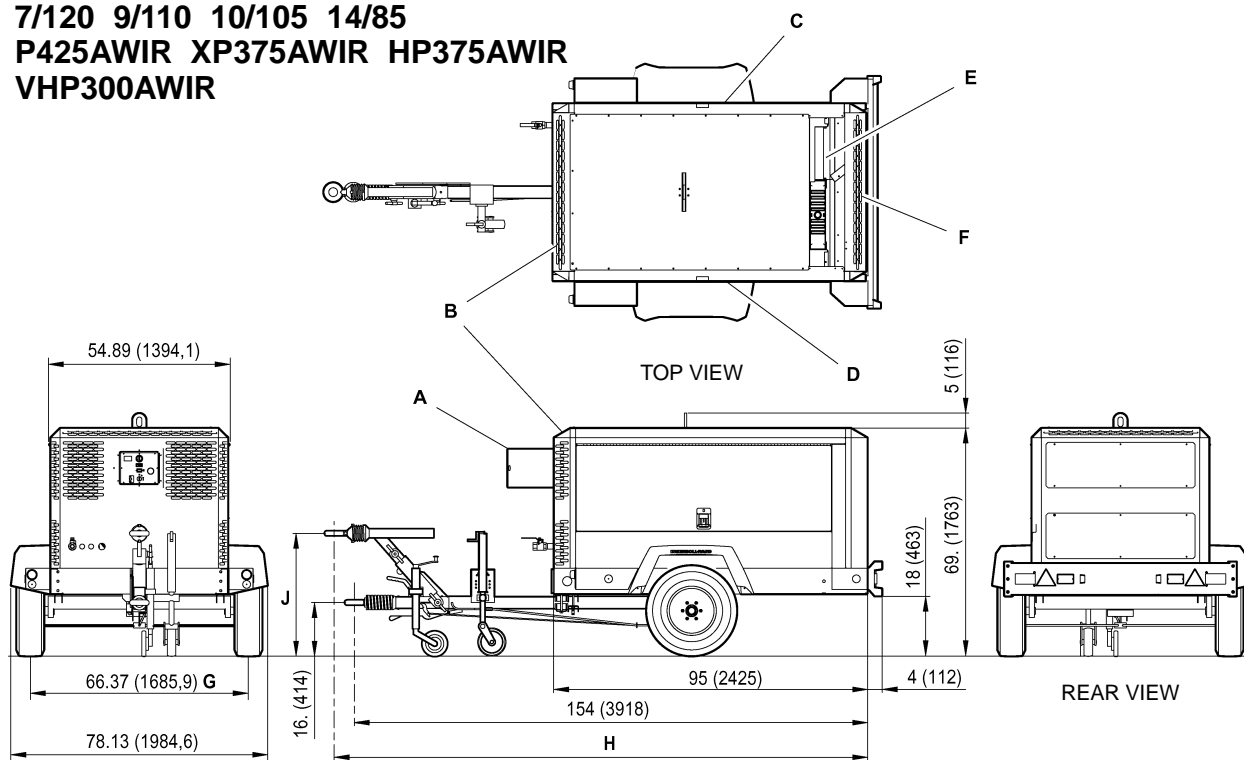

T2228
Revision 00
12/02

MANUFACTURED IN EUROPE

All dimensions in inches(mm)

A Instrument panel access door

B Package air inlet

C Access items:
Separator element & fill
Compressor oil filter
Fuel filters
Dipstick
Engine oil fill
Coolant bottle fill

D Access items:
Fuel fill
Engine oil filter
Fuel filter
Engine and compressor air filter

E Access items:
Radiator fill

F Package air outlet

G Track width

H Variable height drawbar
162 (4114) minimum / 168 (4277) maximum

J Variable height drawbar
17 (420) minimum / 35 (880) maximum

7/170 10/125 14/115
P600WIR HP450WIR VHP400WIR

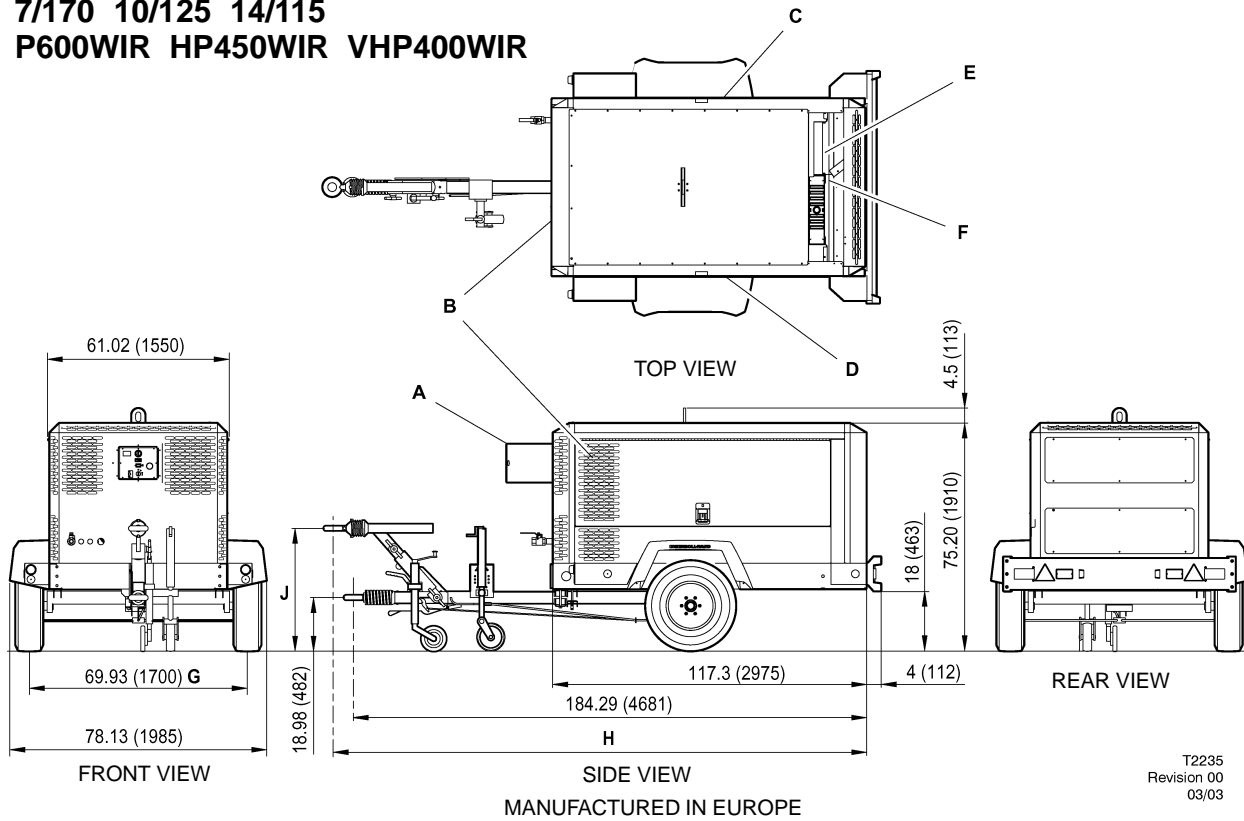

T2235
 Revision 00
 03/03

All dimensions in inches(mm)

A Instrument panel access door

B Package air inlet

C Access items:
 Separator element & fill
 Compressor oil filter
 Fuel filters
 Dipstick
 Engine oil fill
 Coolant bottle fill

D Access items:
 Fuel fill
 Engine oil filter
 Fuel filter
 Engine and compressor air filter

E Access items:
 Radiator fill

F Package air outlet

G Track width

H Variable height drawbar
 184.29 (4681) minimum / 189.21 (4806) maximum

J Variable height drawbar
 18.98 (482) minimum / 37.17 (944) maximum

COMPRESSOR

Actual free air delivery. (7/120) (P425AWIR)	12,0 m ³ min ⁻¹ (425 CFM)	Safety valve setting. (7/120) (P425AWIR)	10 bar (150 PSI)
Actual free air delivery. (9/110) (XP375AWIR)	10,5 m ³ min ⁻¹ (375 CFM)	Safety valve setting. (9/110) (XP375AWIR)	10 bar (200 PSI)
Actual free air delivery. (10/105) (HP375AWIR)	10,5 m ³ min ⁻¹ (375 CFM)	Safety valve setting. (10/105) (HP375AWIR)	14 bar (200 PSI)
Actual free air delivery. (14/85) (VHP300AWIR)	8,5 m ³ min ⁻¹ (300 CFM)	Safety valve setting. (14/85) (VHP300AWIR)	17 bar (250 PSI)
Actual free air delivery. (7/170) (P600WIR)	17,0 m ³ min ⁻¹ (600 CFM)	Safety valve setting. (7/170) (P600WIR)	10 bar (150 PSI)
Actual free air delivery. (10/125) (HP450WIR)	12,8 m ³ min ⁻¹ (450 CFM)	Safety valve setting. (10/125) (HP450WIR)	14 bar (200 PSI)
Actual free air delivery. (14/115) (VHP400WIR)	11,3 m ³ min ⁻¹ (400 CFM)	Safety valve setting. (14/115) (VHP400WIR)	17 bar (250 PSI)
Normal operating discharge pressure. (7/120) (P425AWIR)	7 bar (100 PSI)	Maximum pressure ratio (absolute). (7/120) (P425AWIR)	7,9 : 1
Normal operating discharge pressure. (9/110) (XP375AWIR)	8,6 bar (125 PSI)	Maximum pressure ratio (absolute). (9/110) (XP375AWIR)	9,6 : 1
Normal operating discharge pressure. (10/105) (HP375AWIR)	10,3 bar (150 PSI)	Maximum pressure ratio (absolute). (10/105) (HP375AWIR)	11,3 : 1
Normal operating discharge pressure. (14/85) (VHP300AWIR)	14 bar (200 PSI)	Maximum pressure ratio (absolute). (14/85) (VHP300AWIR)	14,8 : 1
Normal operating discharge pressure. (7/170) (P600WIR)	7 bar (100 PSI)	Maximum pressure ratio (absolute). (7/170) (P600WIR)	7,9 : 1
Normal operating discharge pressure. (10/125) (HP450WIR)	10,3 bar (150 PSI)	Maximum pressure ratio (absolute). (10/125) (HP450WIR)	11,3 : 1
Normal operating discharge pressure. (14/115) (VHP400WIR)	14 bar (200 PSI)	Maximum pressure ratio (absolute). (14/115) (VHP400WIR)	14,8 : 1
Maximum allowable pressure. (7/120) (P425AWIR)	8,6 bar (125 PSI)	Operating ambient temperature. Whisperized	-12°C TO +49°C (10°F TO 120°F)
Maximum allowable pressure. (9/110) (XP375AWIR)	10.3 bar (150 PSI)	Maximum discharge temperature.	120°C (248°F)
Maximum allowable pressure. (10/105) (HP375AWIR)	12.1 bar (175 PSI)	Cooling system.	Oil injection
Maximum allowable pressure. (14/85) (VHP300AWIR)	15.5 bar (225 PSI)	Oil capacity.	36 litres (9.5 GAL)
Maximum allowable pressure. (7/170) (P600WIR)	8,6 bar (125 PSI)	Maximum oil system temperature.	120°C (248°F)
Maximum allowable pressure. (10/125) (HP450WIR)	12.1 bar (175 PSI)	Maximum oil system pressure. (7/120) (P425AWIR)	8,6 bar (125 PSI)
Maximum allowable pressure. (14/115) (VHP400WIR)	15.5 bar (225 PSI)	Maximum oil system pressure. (9/110) (XP375AWIR)	10.3 bar (150 PSI)
		Maximum oil system pressure. (10/105) (HP375AWIR)	12.1 bar (175 PSI)
		Maximum oil system pressure. (14/85) (VHP300AWIR)	15.5 bar (225 PSI)
		Maximum oil system pressure. (7/170) (P600WIR)	8,6 bar (125 PSI)
		Maximum oil system pressure. (10/125) (HP450WIR)	12.1 bar (175 PSI)
		Maximum oil system pressure. (14/115) (VHP400WIR)	15.5 bar (225 PSI)

LUBRICATING OIL SPECIFICATION
(for the specified ambient temperatures).**ABOVE -23°C(-9°F)**

Recommended: Pro-Tec™

Approved: SAE 10W, API CF-4/CG-4

BELOW -23°C(-9°F)

Mandatory: IR Performance 500

Ingersoll-Rand Pro-Tec™ compressor fluid is factory-fitted, for use at all ambient temperatures above -23°C(-9°F).

NOTE: Warranty may be extended only by continuous use of Pro-Tec™ and Ingersoll-Rand oil filters and separators.

No other oil/fluids are compatible with Pro-Tec™

No other oils/fluids should be mixed with Pro-Tec™ because the resulting mixture could cause damage to the aircend.

In the event that Pro-Tec™ is not available and / or the end user needs to use an approved single grade engine oil, the complete system including separator / receiver, cooler and pipework must be flushed clear of the first fill fluid and new Ingersoll-Rand oil filters installed.

When this has been completed, the following oils are approved:

- a) for ambient temperatures above -23°C(-9°F),
SAE 10W, API CF-4/CG-4
- b) for ambient temperatures below -23°C(-9°F),
I-R Performance 500 only.

Safety data sheets can be obtained on request from the lubricant supplier.

For temperatures outside the specified ambient range, consult Ingersoll-Rand.

ENGINE

**7/120 (P425WIR), 9/110 (XP375AWIR),
10/105 (HP375AWIR), 14/85 (VHP300AWIR)**

Type/model.	Ingersoll-Rand
Number of cylinders.	4
Oil capacity.	13.2 litres (3.5 GAL)
Speed at full load. min ⁻¹ (RPM)	2400 revs
Speed at idle. (RPM)	1400 revs min ⁻¹
Electrical system.	24V negative earth
Power available at 2400 revs min ⁻¹	93 kW (125 HP)
Fuel tank capacity GAL)	219.5 litres (58 GAL)
Oil specification	Refer engine section
Coolant capacity	17 litres(4.5 GAL)

ENGINE

7/170 (P600WIR), 10/125 (HP450WIR), 14/115 (VHP400WIR)

Type/model.	Ingersoll-Rand
Number of cylinders.	6
Oil capacity.	22.1 litres (5.75 GAL)
Speed at full load.	2400 revs min ⁻¹ (RPM)
Speed at idle.	1400 revs min ⁻¹ (RPM)
Electrical system.	24V negative earth
Power available at 2400 revs min ⁻¹	126.8 kW (170 HP)
Fuel tank capacity	276 litres (73 GAL)
Oil specification	Refer engine section
Coolant capacity	28.4 litres(7.5 GAL)

SOUND LEVEL DATA ('W' model)

A) To Pneurop code PN8NTC2.	
Equivalent continuous sound pressure level.*	
Rated load	85 dB(A)
(Operator position :-1m from machine)	
Sound power level (84/533/EEC)	101 dB(A)
B) In compliance with 86/188/EEC.	
Average sound pressure level at 10m to 79/113/EEC.*	
	73 dB(A)
(*Machine only :- at maximum load in open site conditions)	
C) EPA Noise	76 dB(A)

FIXED HEIGHT RUNNING GEAR (European Only)

**Braked version
(7/120) (9/110), (10/105), (14/85)**

Shipping weight.	1935kg (4266Lbs)
Maximum weight.	2200kg (4850Lbs)
Maximum horizontal towing force.	2009kg (4429Lbs)
Maximum vertical coupling load (nose weight).	100 kgf (220 Lbs)

FIXED HEIGHT RUNNING GEAR (European Only)

**Braked version
(7/170), (10/125), (14/115)**

Shipping weight.	2364kg (5200Lbs)
Maximum weight.	2598kg (5715Lbs)
Maximum horizontal towing force.	2700kg (5940Lbs)
Maximum vertical coupling load (nose weight).	150 kgf (330 Lbs)

VARIABLE HEIGHT RUNNING GEAR (European Only)

Braked version

(7/120) (9/110), (10/105), (14/85)

Shipping weight.	1965kg (4331Lbs)
Maximum weight.	2200kg (4850Lbs)
Maximum horizontal towing force.	2009kg (4429Lbs)
Maximum vertical coupling load (nose weight).	100 kgf (220 Lbs)

VARIABLE HEIGHT RUNNING GEAR (European Only)

Braked version

(7/170), (10/125), (14/115)

Shipping weight.	2400kg (5280Lbs)
Maximum weight.	2636kg (5800Lbs)
Maximum horizontal towing force.	2900kg (5940Lbs)
Maximum vertical coupling load (nose weight).	150 kgf (330 Lbs)

WHEELS AND TYRES (European) – 7/120, 9/110, 10/105, 14/85

Number of wheels.	2 x 5.5
Tyre size.	205/75 R16
Tyre pressure.	4.5 bar (65 psi)

WHEELS AND TYRES (European) – 7/170, 10/125, 14/115

Number of wheels.	2 x 6.0
Tyre size.	205/75 P17.5
Tyre pressure.	6.5 bar (94 psi)

Further information may be obtained by request through Ingersoll-Rand customer services department.

COMMISSIONING

Upon receipt of the unit, and prior to putting it into service, it is important to adhere strictly to the instructions given below in **PRIOR TO STARTING**.

Ensure that the operator reads and *understands* the decals and consults the manuals before maintenance or operation.

Ensure that the position of the *emergency stop* device is known and recognised by its markings. Ensure that it is functioning correctly and that the method of operation is known.

Running gear drawbar (European Area) – Machines are shipped to some areas with the drawbar removed. Fitting involves four nuts / bolts to secure the drawbar to the axle and two bolts to fit the drawbar to the front of the machine with the saddle and spacer block.

Support the front of the machine, fit the wheel chocks to stop the machine moving and attach the drawbar. Refer to the torque value table in the **MAINTENANCE** section of this manual for the correct torque values.

CAUTION:

This is a safety critical procedure. Double check the torque settings after assembly

Fit the propstand and coupling. Remove the supports and set the machine level.

Before towing the unit, ensure that the tyre pressures are correct (refer to the **GENERAL INFORMATION** section of this manual) and that the handbrake is functioning correctly (refer to the **MAINTENANCE** section of this manual). Before towing the unit during the hours of darkness, ensure that the lights are functioning correctly (where fitted).

Ensure that all transport and packing materials are discarded.

Ensure that the correct fork lift truck slots or marked lifting / tie down points are used whenever the machine is lifted or transported.

When selecting the working position of the machine ensure that there is sufficient clearance for ventilation and exhaust requirements, observing any specified minimum dimensions (to walls, floors etc.).

Adequate clearance needs to be allowed around and above the machine to permit safe access for specified maintenance tasks.

Ensure that the machine is positioned securely and on a stable foundation. Any risk of movement should be removed by suitable means, especially to avoid strain on any rigid discharge piping.

Attach the battery cables to the battery(s) ensuring that they are tightened securely. Attach the negative cable before attaching the positive cable.

WARNING: All air pressure equipment installed in or connected to the machine must have safe working pressure ratings of at least the machine rated pressure, and materials compatible with the compressor lubricant (refer to the GENERAL INFORMATION section).

WARNING: If more than one compressor is connected to one common downstream plant, effective check valves and isolation valves must be fitted and controlled by work procedures, so that one machine cannot accidentally be pressurised / over pressurised by another.

WARNING: If flexible discharge hoses are to carry more than 7 bar pressure then it is recommended that safety retaining wires are used on the hoses.

OPERATING INSTRUCTIONS

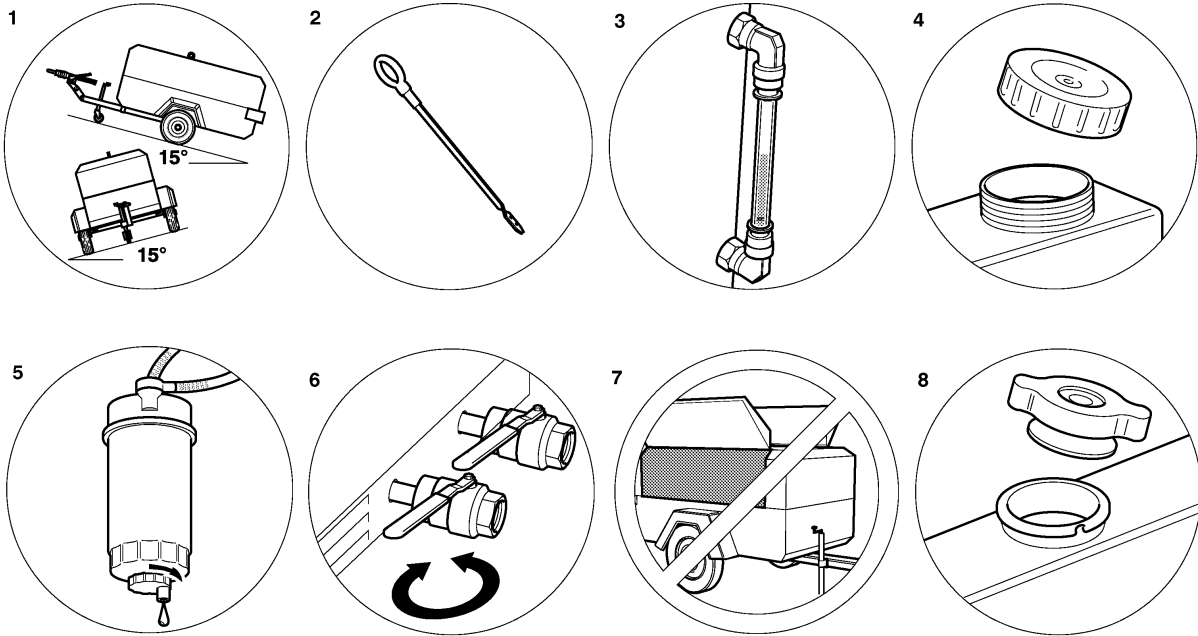

T2221
Revision 00
12/00

PRIOR TO STARTING

1. Place the unit in a position that is as level as possible. The design of the unit permits a 15 degree lengthways and sideways limit on out of level operation. It is the engine, not the compressor, that is the limiting factor.

When the unit has to be operated out of level, it is important to keep the engine oil level near the high level mark (with the unit level).

CAUTION: Do not overfill either the engine or the compressor with oil.

2. Check the engine lubrication oil in accordance with the operating instructions in the *Engine Operator's Manual*.

3. Check the compressor oil level in the sight glass located on the separator tank.

4. Check the diesel fuel level. A good rule is to top up at the end of each working day. This prevents condensation from occurring in the tank.

CAUTION: Use only a No. 2-D diesel fuel oil with a minimum octane number of 45 and a sulphur content not greater than 0,5%.

CAUTION: When refuelling:—

- . switch off the engine.
- . do not smoke.
- . extinguish all naked lights.
- . do not allow the fuel to come into contact with hot surfaces.
- . wear personal protective equipment.

5. Drain the fuel filter water separator of water, ensuring that any released fuel is safely contained.

6. Open the service valve(s) to ensure that all pressure is relieved from the system. Close the service valve(s).

7. CAUTION: Do not operate the machine with the canopy/doors in the open position as this may cause overheating and operators to be exposed to high noise levels.

8. Check the radiator coolant level (with the unit level).

Check the air restriction indicator(s). Refer to the *MAINTENANCE* section of this manual.

When starting or operating the machine in temperatures below or approaching 0°C, ensure that the operation of the regulation system, the unloader valve, the safety valve, and the engine are not impaired by ice or snow, and that all inlet and outlet pipes and ducts are clear of ice and snow.

Control Panel

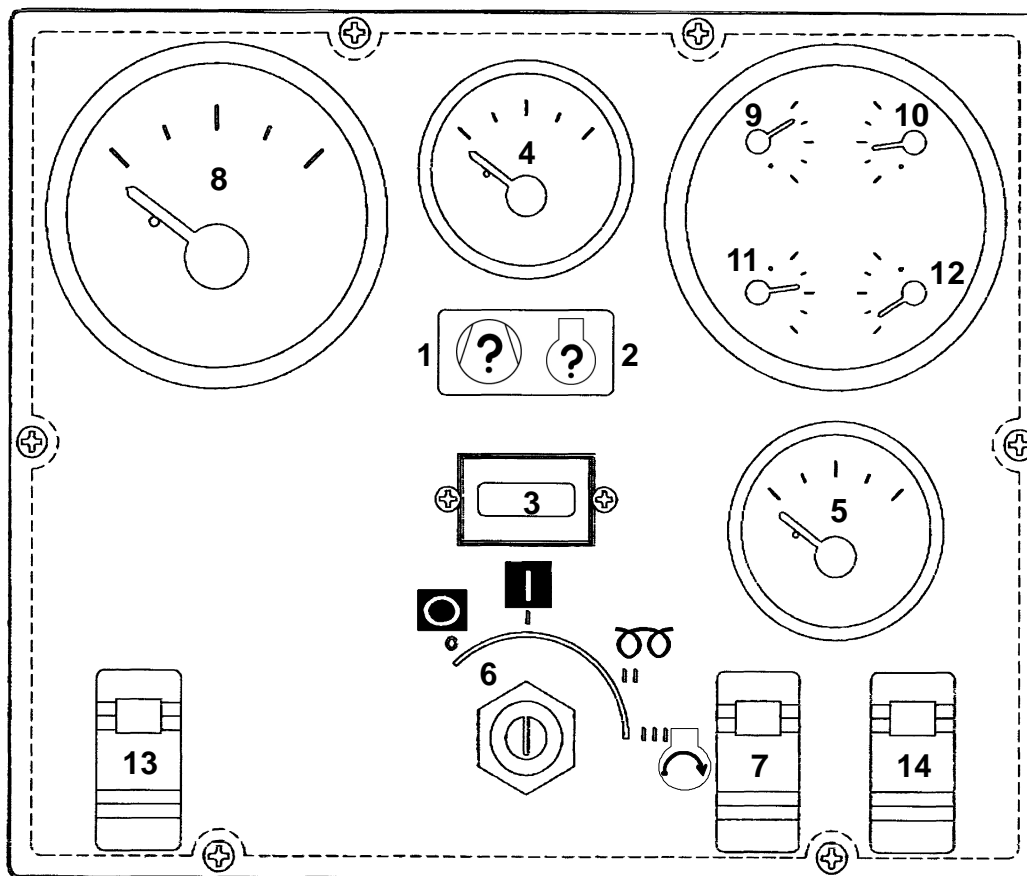

DIAGNOSTIC/AUTO SHUTDOWN (STANDARD)

1. **Compressor fault** – Needs attention. See Wedge diagnostic panel for more detail.
2. **Engine Fault** – Needs attention. See Wedge diagnostic panel for more detail.
3. **Hourmeter** – Records running time for maintenance.
4. **Compressor Discharge Pressure Gauge** – Indicates pressure in receiver tank, psi (kPa).
5. **Fuel Level Gauge** – Indicates amount of fuel in tank.

CONTROLS (STANDARD)

6. **Power Switch** – Flip "ON" to activate systems prior to Starting. Flip "OFF" to stop engine.
7. **Service Air Switch** – After warm-up, PUSH. Provides full air pressure at the service outlet.

OPTIONAL CONTROLS

8. **Engine Speed Gauge** – Indicates engine speed.
9. **Discharge Air Temp. Gauge** – Indicates in °F and °C. Normal operating range: 185°F/85°C to 248°F/120°C.
10. **Engine Oil Pressure Gauge** – Indicates engine oil pressure (psi (kPa)).
11. **Engine Water Temp Gauge** – Indicates coolant temperature, with normal operating range from 180°F/82°C to 210°F/99°C.
12. **Voltmeter** – Indicates battery condition.
13. **Spare**
14. **Wait To Start Lamp.**

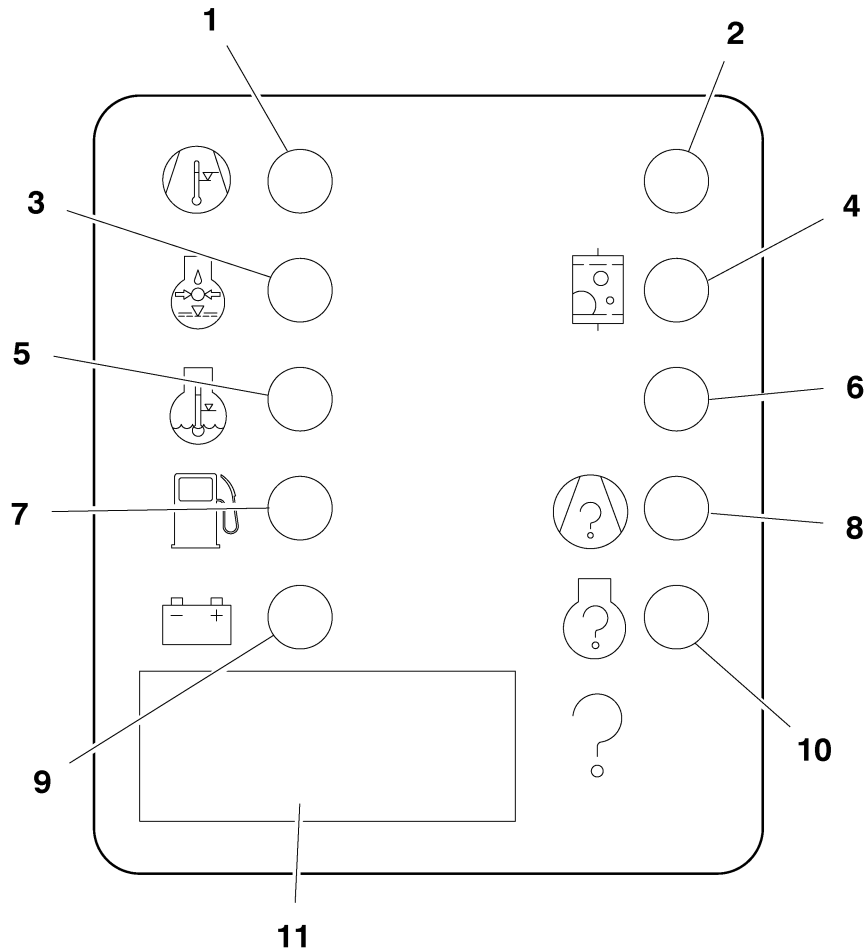

T2226
Revision 00
12/02



WEDGE DIAGNOSTIC DISPLAY PANEL.

The Wedge diagnostic display panel is arranged as shown above. A description of each diagnostic indicator is as follows.

1. **High Compressor Temp:** Fault indicator lamp. Indicates shutdown due to high compressor temperature.
2. **Spare**
3. **Low Engine Oil Pressure:** Fault indicator lamp. Indicates shutdown due to low engine oil pressure.
4. **Restricted Air Filter:** Alarm indicator lamp. Indicates engine/compressor air inlet filters need service.
5. **High Engine Coolant Temp:** Fault indicator lamp. Indicates shutdown due to high engine water temperature.
6. **Spare**
7. **Low Fuel Level:** Fault indicator lamp. Indicates shutdown due to low fuel level. Lamp blinks at low fuel warning.
8. **Compressor Malfunction:** Fault indicator lamp. Indicates shutdown due to compressor system fault. Refer to Fault Code List.
9. **Low Battery Voltage:** Alarm indicator lamp. Indicates battery or charging system requires service.
10. **Engine Malfunction:** Engine Fault code. Refer to service card or engine manual for codes and service requirements.
11. **Malfunction Code (4 Digit):** Compressor or engine fault. Refer to manual for list of codes and service requirements.

Wedge Diagnostic Display Codes



If the  fault indicator lamp is illuminated, refer to the  Alert/Shutdown list below.

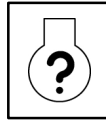

If the  fault indicator lamp is illuminated, refer to the  Engine diagnostic list below.

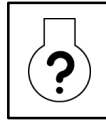

ALERT/SHUTDOWN CONDITIONS Version: 1.40

Condition	Alert		Shutdown		Delay (sec.)
	Code	Light (Blinks)	Code	Light (Steady)	
Engine Speed <900 RPM			1	CPRSR Malf.	30
Engine Speed >2500 RPM			2	CPRSR Malf.	30
Engine Crank Time Exceeded			3	CPRSR Malf.	0
Intake Manifold Temperature > 180 deg. F	6	CPRSR Malf.			
Engine Not Responding To Throttle Command	10	CPRSR Malf.			
Engine Shut Itself Down: reason unknown	29	CPRSR Malf.			
Disch. Temp (RT2) Sensor Fault			32	CPRSR Malf.	10
Sep. Tank Pressure (PT1) Sensor Fault	33	CPRSR Malf.			
Separator Tank Temp.> 247 deg.F)			50	CPRSR Malf.	3
Machine ID Not Valid			51	CPRSR Malf.	0
Sep. Tank Temp. (RT1) Sensor Fault			53	CPRSR Malf.	10
Reg. System Pressure (PT2) Sensor Fault	54	CPRSR Malf.			
Serial Comm. Problem	70	CPRSR Malf.			
CAN Bus Problem	71	CPRSR Malf.			

Condition	Alert		Shutdown		Delay (sec.)
	Code	Light (Blinks)	Code	Light (Steady)	
Dedicated Lights:					
Low Fuel Level		Fuel Level		Fuel Level	3
Air Filter Restriction (Option)		Soiled Filter			
Low Battery Voltage		Battery Charging Condition			
Engine Oil Pressure < 18 PSI		Low Engine Oil Pressure			
Engine Coolant Temperature >= 215 deg. F		High Engine Temp.			
Engine Coolant Temperature >= 220 deg. F				High Comp. Temp.	10
High Discharge Temp. (RT2 > 247 deg. F)				High Comp. Temp.	3

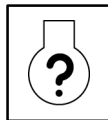

ENGINE DIAGNOSTIC CODES

Listing of Diagnostic Trouble Codes (DTCs)		
Displayed Code	FMI*	Definition
28	3	Analog Throttle (B) Input Voltage High
	4	Analog Throttle (B) Input Voltage Low
29	3	Analog Throttle (A) Input Voltage High
	4	Analog Throttle (A) Input Voltage Low
91	3	Multi-state Throttle Input Voltage High
	4	Multi-state Throttle Input Voltage Low
100	1	Engine Oil Pressure Extremely Low
	3	Engine Oil Pressure Input Voltage High
	4	Engine Oil Pressure Input Voltage Low
	18	Engine Oil Pressure Moderately Low
105	3	Manifold Air Temperature Input Voltage High
	4	Manifold Air Temperature Input Voltage Low
	16	Manifold Air Temperature Moderately High
110	0	Engine Coolant Temperature High Most Severe
	3	Engine Coolant Temperature Input Voltage High
	4	Engine Coolant Temperature Input Voltage Low
	15	Engine Coolant Temperature High Least Severe
	16	Engine Coolant Temperature High Moderately Severe
158	17	ECU Power Down Error
174	3	Fuel Temperature Input Voltage High
	4	Fuel Temperature Input Voltage Low

Listing of Diagnostic Trouble Codes (DTCs)		
Displayed Code	FMI*	Definition
	16	Fuel Temperature Moderately High
190	0	Engine Overspeed Extreme
	16	Engine Overspeed Moderate
620	3	Sensor Supply Voltage High
	4	Sensor Supply Voltage Low
637	2	Crankshaft Position Input Noise
	10	Crankshaft Position Input Pattern Error
970	31	Auxiliary Engine Shutdown Switch Active
971	31	External Engine Derate Switch Active
1076	0	Pump Control Valve Closure Too Long
	1	Pump Control Valve Closure Too Short
	5	Pump Solenoid Circuit Open
	6	Pump Solenoid Circuit Severely Shorted
	7	Pump Control Valve Closure Not Detected
	10	Pump Solenoid Circuit Moderately Shorted
1109	31	Engine Shutdown Warning
1110	31	Engine Shutdown
1569	31	Fuel Derate
2000	6	Internal ECU Failure

* FMI (Failure Mode Indicator) – Requires engine diagnostic tool to display.

STARTING THE MACHINE

WARNING: Under no circumstances should volatile liquids such as Ether be used for starting this machine.

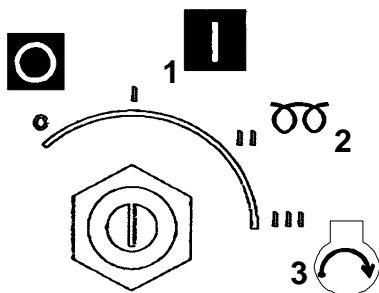

All normal starting functions are incorporated in the key operated switch.

- Turn the key switch to position 1. The engine fault and compressor fault lamps will flash..

Wait To Start Lamp.

- Turn the key switch to position 1 until the Wait To Start Lamp. (14) extinguishes.
- Turn the key switch to crank position (3) (engine start position)
- NOTE: Position (2) not used on AWIR models.
- Release to position (1) when engine starts. The engine will now be running at a reduced speed.

At temperatures below 0°C or if there is difficulty starting first time:

- Open the service valve fully, with no hose connected.
- Complete starting sequence above.
- Close service valve as soon as engine runs freely.
- Do not allow machine to run for long periods with service valve open.
- Allow the engine to reach operating temperature.
- At this point in the operation of the machine it is safe to apply full load to the engine.

NOTE: Wear hearing protection at all times when the engine is started with the service valve open and air is flowing from the valve.

PUSH AFTER WARM UP

NOTE: In order to allow the machine to start at a reduced load, a valve, which is operated by a button located on the instrument panel, is incorporated in the regulation system. (The valve automatically returns to the start position when the machine is switched off and air pressure relieved from the system).

- Allow the engine to reach its operating temperature – then press the button (7).
- At this point in the operation of the machine it is safe to apply full load to the engine.

DUAL PRESSURE WHEN FITTED

Machines which operate in excess of 7 bar (100 psi) can optionally be fitted with a dual pressure switch inside the unit. This switch selects between 7 bar (100 psi) and the machine rated pressure, cfm remains nominally constant.

Starting and stopping are unaffected by the selection and during normal running the selector switch may be safely operated. Precaution must be taken to ensure that downstream equipment is rated to suit the available pressure.

The pressure gauge indicates which setting has been selected.

STOPPING THE MACHINE

- Close the service valve.
- Allow the machine to run unloaded for a short period of time to reduce the engine temperature.
- Turn the start switch to the 0 (off) position.

NOTE: As soon as the engine stops, the automatic blowdown valve will relieve all pressure from the system.

If the automatic blowdown valve fails to operate, then pressure must be relieved from the system by means of the service valve(s).

CAUTION: Never allow the machine to stand idle with pressure in the system.

EMERGENCY STOPPING

In the event that the unit has to be stopped in an emergency, **TURN THE KEY SWITCH LOCATED ON THE INSTRUMENT PANEL TO THE 0 (OFF) POSITION.**

RE-STARTING AFTER AN EMERGENCY

If the machine has been switched off because of a machine malfunction, then identify and correct the fault before attempting to re-start.

If the machine has been switched off for reasons of safety, then ensure that the machine can be operated safely before re-starting.

Refer to the *PRIOR TO STARTING* and *STARTING THE UNIT* instructions earlier in this section before re-starting the machine.

MONITORING DURING OPERATION

Should any of the safety shut-down conditions occur, the unit will stop.

Refer to the Wedge diagnostic display codes table for a listing of shutdown conditions.

CAUTION: *To ensure an adequate flow of oil to the compressor at low temperature, never allow the discharge pressure to fall below 3,5 bar (50 psi)*

DECOMMISSIONING

When the machine is to be permanently decommissioned or dismantled, it is important to ensure that all hazard risks are either eliminated or notified to the recipient of the machine. In particular:–

- . Do not destroy batteries or components containing asbestos without containing the materials safely.
- . Do not dispose of any pressure vessel that is not clearly marked with its relevant data plate information or rendered unusable by drilling, cutting etc.
- . Do not allow lubricants or coolants to be released into land surfaces or drains.
- . Do not dispose of a complete machine without documentation relating to instructions for its use.

ENGINE

Engine Serial Number Plate

Each engine has a 13–digit engine serial number.

The engine's serial number plate is located on the right–hand side of cylinder block behind the fuel filter.

Fuels, Lubricants, and Coolant

Diesel Fuel

Consult your local fuel distributor for properties of the diesel fuel available in your area.

In general, diesel fuels are blended to satisfy the low temperature requirements of the geographical area in which they are marketed.

Diesel fuels specified to EN 590 or ASTM D975 are recommended.

Required fuel properties

In all cases, the fuel must meet the following properties:

Cetane number of 45 minimum. Cetane number greater than 50 is preferred, especially for temperatures below -20°C (-4°F) or elevations above 1500 m (5000 ft).

Cold Filter Plugging Point (CFPP) below the expected low temperature OR **Cloud Point** at least 5°C (9°F) below the expected low temperature.

Fuel lubricity should pass a minimum load level of 3100 grams as measured by ASTM D6078 or, maximum scar diameter of 0.45 mm as measured by ASTM D6079.

Sulfur content:

- Diesel fuel quality and fuel sulfur content must comply with all existing regulations for the area in which the engine operates.
- Sulfur content less than 0.05% (500 ppm) is preferred.
- If diesel fuel with sulfur content greater than 0.05% (500 ppm) is used, crankcase oil service intervals may be affected. (See recommendation for Diesel Engine Oil.)
- DO NOT use diesel fuel with sulfur content greater than 1.0%.

IMPORTANT: DO NOT mix used engine oil or any other type of lubricating oil with diesel fuel.

Bio–Diesel Fuel

Bio–diesel fuels may be used ONLY if the bio–diesel fuel properties meet the latest edition of ASTM PS121, DIN 51606 or equivalent specification.

It has been found that bio–diesel fuels may improve lubricity in concentrations up to a 5% blend in petroleum diesel fuel.

When using a blend of bio–diesel fuel, the engine oil level must be checked daily when the air temperature is -10°C (14°F) or lower. If the oil becomes diluted with fuel, shorten oil change intervals accordingly.

IMPORTANT: Raw pressed vegetable oils are NOT acceptable for use for fuel in any concentration.

These oils do not burn completely, and will cause engine failure by leaving deposits on injectors and in the combustion chamber.

Handling and Storing Bio–Diesel Fuel

WARNING: Handle fuel carefully. Do not fill the fuel tank when engine is running.

DO NOT smoke while you fill the fuel tank or service the fuel system.

Fill the fuel tank at the end of each day's operation to prevent water condensation and freezing during cold weather.

Keep all storage tanks as full as practicable to minimize condensation.

Ensure that all fuel tank caps and covers are installed properly to prevent moisture from entering.

Monitor water content of the fuel regularly.

Fuel filter may require more frequent replacement due to premature plugging.

Check engine oil level daily prior to starting engine. A rising oil level may indicate fuel dilution of the engine oil.

When fuel is stored for an extended period or if there is a slow turnover of fuel, add a fuel conditioner to stabilize the fuel and prevent water condensation. Contact your fuel supplier for recommendations.

Diesel Fuel Storage

WARNING: Handle fuel carefully. Do not fill the fuel tank when engine is running.

DO NOT smoke while you fill the fuel tank or service the fuel system.

Fill the fuel tank at the end of each day's operation to prevent water condensation and freezing during cold weather.

IMPORTANT: DO NOT store diesel fuel in galvanized containers. Diesel fuel stored in galvanized containers reacts with zinc coating on container to form zinc flakes. If fuel contains water, a zinc gel will also form. The gel and flakes will quickly plug fuel filters, damage injection nozzles and injection pump.

DO NOT use brass-coated containers for fuel storage. Brass is an alloy of copper and zinc.

Store diesel fuel in plastic, aluminum, and steel containers specially coated for diesel fuel storage.

Avoid storing fuel over long periods of time. If fuel is stored for more than a month prior to use, or there is a slow turnover in fuel tank or supply tank, add a fuel conditioner to stabilize the fuel, prevent water condensation.

Minimizing the Effect of Cold Weather on Diesel Engines

Ingersoll-Rand diesel engines are designed to operate effectively in cold weather.

See your authorized engine distributor or servicing dealer for additional information and availability of cold weather aids.

Use Grade No. 1-D Fuel

When temperatures fall below 5°C (40°F), Grade No. 1-D fuel is best suited for cold weather operation.

Diesel Fuel Additive

IMPORTANT: Treat fuel when outside temperature drops below 0°C (32°F). For best results, use with untreated fuel. Follow all recommended instructions on label.

Use a fuel conditioner (Winter) to treat fuel during the cold weather season. Winter formulation is a combination diesel fuel conditioner and anti-gel additive.

Diesel Engine Oil

Use SAE15W-40 oil viscosity based on the expected air temperature range of 10°F to 122°F (-12°C-40°C) during the period between oil changes.

The following oil is preferred:

- Pro-Tec™ Engine Fluid

Other oils may be used if they meet one or more of the following:

- API Service Classification CI-4
- API Service Classification CH-4
- ACEA Specification E3
- ACEA Specification E4
- ACEA Specification E5

Multi-viscosity diesel engine oils are preferred.

Diesel fuel quality and sulfur content must comply with all existing emissions regulations for the area in which the engine operates.

If diesel fuel with sulfur content greater than 0.05% (500 ppm) is used, reduce the oil and filter change interval by 100 hours.

If diesel fuel with sulfur content greater than 0.5% (5000 ppm) is used, reduce the service interval by 50%.

Diesel fuel with sulfur content greater than 1.0% (10,000 ppm) is not recommended.

Diesel Engine Coolant

The engine cooling system is filled to provide year-round protection against corrosion and cylinder liner pitting, and winter freeze protection to -37°C (-34°F).

Low silicate ethylene glycol base coolants for heavy-duty engines may be used if they meet one of the following specifications:

- ASTM D5345 (pre-diluted coolant)
- ASTM D4985 (coolant concentrate) in a 40 to 60% mixture of concentrate with quality water.

Coolants meeting these specifications require use of supplemental coolant additives, formulated for heavy-duty diesel engines, for protection against corrosion and cylinder liner erosion and pitting.

A 50% mixture of ethylene glycol engine coolant in water provides freeze protection to -37°C (-34°F). If protection at lower temperatures is required, consult your dealer for recommendations.

Water quality is important to the performance of the cooling system. Distilled, or de-mineralized water is recommended for mixing with ethylene glycol base engine coolant concentrate.

Chlorides	<40mg/L
Sulfates	<100 mg/L
Total Dissolved Solids	<340 mg/L
Total Hardness	<170 mg/L
pH	5.5 to 9.0

IMPORTANT: Do not use cooling system sealing additives or antifreeze that contains sealing additives.

Supplemental Coolant Additives

The concentration of coolant additives is gradually depleted during engine operation. For all recommended coolants, replenish additives between drain intervals by adding a supplemental coolant additive every 12 months.

IMPORTANT: Only use coolant additive to replenish the coolant. Do not use additive when the entire system is drained and refilled.

Consult the coolant supplier and follow the manufacturer's recommendation for use of supplemental coolant additives.

The use of non-recommended supplemental coolant additives may result in additive drop-out and gelation of the coolant.

Add the manufacturer's recommended concentration of supplemental coolant additive. DO NOT add more than the recommended amount.

Coolant Drain Intervals

Drain the factory fill engine coolant, flush the cooling system, and refill with new coolant after the first 3 years or 3000 hours of operation. Subsequent drain intervals are determined by the coolant used for service. At each interval, drain the coolant, flush the cooling system, and refill with new coolant.

Operating in Warm Temperature Climates

Ingersoll-Rand engines are designed to operate using glycol base engine coolants.

Always use a recommended glycol base engine coolant, even when operating in geographical areas where freeze protection is not required.

IMPORTANT: Water may be used as coolant in emergency situations only.

Foaming, hot surface aluminum and iron corrosion, scaling, and cavitation will occur when water is used as the coolant, even when coolant conditioners are added.

Drain cooling system and refill with recommended glycol base engine coolant as soon as possible.

Engine Break-In Service

The engine is ready for normal operation. However, extra care during the first 100 hours of operation will result in more satisfactory long-term engine performance and life. DO NOT exceed 100 hours of operation with break-in oil.

Lubrication and Maintenance Service Interval Chart

NOTE: The Service intervals below are for standard industrial engines. See details in Sections which follow these charts.

Item	Lubrication and Maintenance Service Intervals			
	Daily	500 Hours/12 Months	2000 Hours/24 Months	As Required
Check Engine Oil and Coolant Level				
Check Fuel Filter/Water Bowl	•			
Check Air Cleaner Dust Unloader Valve & Restriction Indicator Gauge ^a	•			
Visual Walk Around Inspection	•	•		
Service Battery		•		
Check Manual Belt Tensioner and belt wear		•		
Change Engine Oil And Replace Oil Filter		•		
Clean Crankcase Vent Tube		•		
Check Air Intake Hoses, Connections, & System		•		
Replace Fuel Filter Elements—Bleed Fuel System		•		
Check Belt Tensioner and Belt Wear		•		
Check Engine Electrical Ground Connection		•		
Check Cooling System		•		
Pressure Test Cooling System		•		
Flush Cooling System			•	
Test Thermostats			•	
Check and Adjust Engine Valve Clearance			•	
Add Coolant				•
Replace Air Cleaner Elements				•
Replace Poly-Vee Belt				•

- A Replace primary air cleaner element when restriction indicator shows a vacuum of 625 mm (25 in.) H₂O.
- B During engine break-in, change the oil and filter for the first time before 100 hours of operation.
- C If the recommended engine oils, or Pro-Tec™ is not used, the oil and filter change interval is reduced to every 250 hours. If diesel fuel with a sulfur content greater than 0.05% is used, the oil and filter change interval is also reduced.

Lubrication & Maintenance/Daily

Daily Pre-starting Checks

Do the following BEFORE STARTING THE ENGINE for the first time each day:

Check engine oil level on dipstick.

IMPORTANT: DO NOT add makeup oil until the oil level is BELOW the crosshatch marks on the dipstick.

IMPORTANT: DO NOT fill above the top mark on the dipstick. Oil levels anywhere within crosshatch are considered in the acceptable range.

To change engine oil and oil filter:

Check the fuel filters for water or debris. If filter is fitted with a see-through bowl, drain as needed based on a daily visual inspection.

IMPORTANT: Drain water into a suitable container and dispose of properly.

- a) Loosen drain plugs (A) at bottom of fuel filters or bowls, if equipped, two or three turns.
- b) Loosen air bleed plug (B) two full turns on fuel filter mounting and drain water from bottom until fuel starts to drain out.
- c) When fuel starts to drain out, tighten drain plugs securely.

After draining water from the fuel filters, the filters must be primed by bleeding all air from the fuel system.

Changing Engine Oil and Replacing Filter

Your engine is equipped with a special oil filter.

NOTE: During break-in, change engine oil and filter for the first time before 100 hours maximum of operation.

After break-in, the oil and filter change interval is 500 hours or every 12 months, whichever comes first.

NOTE: If diesel fuel with a sulfur content greater than 0.05% (500 ppm) is used, the oil and filter change interval is reduced.

To change engine oil and oil filter:

1. Run engine approximately 5 minutes to warm up oil. Shut engine off.
2. Remove oil pan drain plug.
3. Drain crankcase oil from engine while warm.
4. Turn filter element using a suitable filter wrench to remove. Discard oil filter element.

Important: Filtration of oils is critical to proper lubrication. Always change filter regularly.

5. Apply clean engine oil to the new filter at the inner and outer seals and to filter threads.
6. Wipe both sealing surfaces of the header with a clean rag. Ensure dust seal is in place, replace if damaged.

IMPORTANT: When installing filter element, HAND TIGHTEN only. A filter wrench may be used for REMOVAL ONLY.

7. Install and tighten oil filter by hand until firmly against dust seal. DO NOT apply an extra 3/4 to 1-1/4 turn after gasket contact as done with standard filters.
8. Tighten drain plug to specifications.

Specification
Oil Pan Drain Plug With Copper Washer— Torque 70 N•m (52 lb ft)
Oil Pan Drain Plug With O-Ring— Torque 50 N•m (37 lb ft)

9. Fill engine crankcase with Pro-Tec™ Engine Fluid.

To determine the correct oil fill quantity for your engine, see ENGINE CRANKCASE OIL FILL QUANTITIES in the Specifications Section of this manual.

IMPORTANT: Immediately after completing any oil change, crank engine for 30 seconds without permitting engine to start. This will help insure adequate lubrication to engine components before engine starts.

NOTE: Crankcase oil capacity may vary slightly. ALWAYS fill crankcase within crosshatch marks on dipstick. DO NOT overfill.

10. Start engine and run to check for possible leaks.
11. Stop engine and check oil level after 10 minutes. Oil level reading should be within crosshatch of dipstick.

Cleaning Crankcase Vent Tube

If you operate the engine in dusty conditions, clean the tube at shorter intervals.

1. Remove and clean crankcase vent tube.
2. Install the vent tube. Be sure the O-ring fits correctly in the rocker arm cover for elbow adapter.

Replacing Fuel Filter Elements

Engine is equipped with a primary fuel filter (or pre-filter) with water bowl and a final filter. Both filters are replaced at the same 500-hour interval.

CAUTION: Escaping fluid under pressure can penetrate the skin causing serious injury. Relieve pressure before disconnecting fuel or other lines. Tighten all connections before applying pressure. Keep hands and body away from pinholes and nozzles which eject fluids under high pressure. Use a piece of cardboard or paper to search for leaks. Do not use your hand.

1. Close fuel shut-off valve, if equipped.
2. Thoroughly clean fuel filter assemblies and surrounding areas.
3. Disconnect water sensor wiring (if equipped).
4. Loosen drain plugs and drain fuel into a suitable container.

NOTE: Lifting up on retaining ring as it is rotated helps to get it past raised locators.

5. Firmly grasp the retaining ring and rotate it counterclockwise 1/4 turn. Remove ring with filter element.
6. Inspect filter mounting base for cleanliness. Clean as required.

NOTE: Raised locators on fuel filter canisters must be indexed properly with slots in mounting base for correct installation.

7. Install new filter elements onto mounting bases. Be sure elements are properly indexed and firmly seated on bases. It may be necessary to rotate filters for correct alignment.

If equipped with water separator bowl (E), remove filter element from separator bowl. Drain and clean separator bowl. Dry with compressed air. Install bowl onto new element. Tighten securely.

8. Align keys on filter element with slots in filter base.
9. Install retaining ring onto mounting base making certain dust seal is in place on filter base. Hand tighten ring (about 1/3 turn) until it "snaps" into the detent. DO NOT overtighten retaining ring.

NOTE: The proper installation is indicated when a "click" is heard and a release of the retaining ring is felt. A plug is provided with the new element for plugging the used element.

10. Reconnect water sensor wiring (if equipped).
11. Open fuel shut-off valve and bleed the fuel system.

Checking Belt Tensioner Spring Tension and Belt Wear (Automatic Tensioner)

Belt drive systems equipped with automatic (spring) belt tensioners cannot be adjusted or repaired. The automatic belt tensioner is designed to maintain proper belt tension over the life of the belt. If tensioner spring tension is not within specification, replace tensioner assembly.

Checking Belt Wear

The belt tensioner is designed to operate within the limit of arm movement provided by the cast stops when correct belt length and geometry is used.

Visually inspect cast stops on belt tensioner assembly.

If the tensioner stop on swing arm is hitting the fixed stop, check mounting brackets (alternator, belt tensioner, idler pulley, etc.) and the belt length. Replace belt as needed

Checking Tensioner Spring Tension

A belt tension gauge will not give an accurate measure of the belt tension when automatic spring tensioner is used. Measure tensioner spring tension using a torque wrench and procedure outlined below:

1. Release tension on belt using a breaker bar and socket on tension arm. Remove belt from pulleys.
2. Release tension on tension arm and remove breaker bar.
3. Put a mark on swing arm of tensioner as shown.
4. Measure 21 mm (0.83 in.) and put a mark on tensioner mounting base.
5. Install torque wrench so that it is aligned with centers of pulley and tensioner. Rotate the swing arm using a torque wrench until marks are aligned.
6. Record torque wrench measurement and compare with specification below. Replace tensioner assembly as required.

Specification
Spring Tension—Torque 18–22 N•m (13–16 lb-ft)

NOTE: Threads on belt tensioner roller cap screw are LEFT-HAND threads.

Checking Engine Electrical Ground Connections

Keep all engine ground connections clean and tight to prevent electrical arcing which can damage electronic components.

Replenishing Supplemental Coolant Additives (SCAs) Between Coolant Changes

NOTE: If system is to be filled with coolant that does not contain SCAs, the coolant must be precharged.

Through time and use, the concentration of coolant additives is gradually depleted during engine operation. Periodic replenishment of inhibitors is required. The cooling system must be recharged with additional supplemental coolant additives available in the form of liquid coolant conditioner.

Maintaining the correct coolant conditioner concentration (SCAs) and freeze point is essential in your cooling system to protect against rust, liner pitting and corrosion, and freeze-ups due to incorrect coolant dilution.

DO NOT mix one brand of SCA with a different brand.

Recharge the system per instructions printed on label of the Coolant Conditioner.

IMPORTANT: Always maintain coolant at correct level and concentration. DO NOT operate engine without coolant even for a few minutes.

If frequent coolant makeup is required, the glycol concentration should be checked to ensure that the desired freeze point is maintained. Follow manufacturer's instructions provided with Coolant/Battery Tester.

Add the manufacturer's recommended concentration of supplemental coolant additive. DO NOT add more than the recommended amount.

The use of non-recommended supplemental coolant additives may result in additive drop-out and gelation of the coolant.

If other coolants are used, consult the coolant supplier and follow the manufacturer's recommendation for use of supplemental coolant additives.

Replacing Fan and Alternator Belts

Refer to CHECKING BELT TENSIONER SPRING TENSION AND BELT WEAR in Lubrication and Maintenance/500 Hour/12 Month Section for additional information on the belt tensioner.

1. Inspect belts for cracks, fraying, or stretched out areas. Replace if necessary.
2. To replace belt with automatic tensioner, release tension on belt using a breaker bar and socket on tension arm.

To replace belt with manual tensioner, release tension at belt tensioner.

3. Remove poly-vee belt from pulleys and discard belt.
4. Install new belt, making sure belt is correctly seated in all pulley grooves. Refer to belt routing at right for your application.
5. Apply tension to belt with tensioner. Remove socket.
6. Start engine and check belt alignment.

Bleeding the Fuel System

Bleed the Fuel System (Engines with Electronic Fuel Systems and Stanadyne DE10 Pump)

CAUTION: Escaping fluid under pressure can penetrate the skin causing serious injury. Avoid hazards by relieving pressure before disconnecting hydraulic or other lines. Tighten all connections before applying pressure. Search for leaks with a piece of cardboard. Protect hands and body from high pressure fluids.

Any time the fuel system has been opened up for service (lines disconnected or filters removed), it will be necessary to bleed air from the system.

The fuel system may be bled at one of several locations. Choose the best location for your engine/machine application.

1. Loosen the air bleed vent screw two full turns by hand on fuel filter base.
2. Operate fuel supply pump primer lever (B) or primer button on fuel filter base (if equipped).
3. Tighten bleed plug securely, continue operating primer until pumping action is not felt.
4. Start engine and check for leaks.

If engine will not start, it may be necessary to bleed air from fuel system at fuel injection pump or injection nozzles as explained next.

At Fuel Injection Pump

1. Loosen fuel return line at fuel injection pump.
2. Operate fuel supply pump primer lever or primer button on fuel filter base (if equipped).
3. As soon as fuel flow is free from air bubbles, tighten fuel return line to specifications. Primer lever is spring-loaded and will return to normal position.

Specification
Fuel Injection Pump Return Line—Torque 27 N•m (20 lb–ft)

At Fuel Injection Nozzles

IMPORTANT: Always use a backup wrench when loosening or tightening fuel lines at nozzles and/or injection pump to avoid damage.

1. Using **two** open-end wrenches, loosen two fuel line connections at injection nozzles.
2. Crank engine over with starter motor for 15 seconds (but do not start engine) until fuel free from bubbles flows out of loosened connection. Retighten connection to specifications.

Specification
Fuel Injection Nozzle Delivery Lines—Torque 27 N•m (20 lb–ft)

3. Repeat procedure for remaining injection nozzles (if necessary) until all air has been removed from fuel system.

If engine still will not start, see your authorized servicing dealer or engine distributor.

Do Not Modify Fuel System

IMPORTANT: Modification or alteration of the injection pump, the injection pump timing, or the fuel injectors in ways not recommended by the manufacturer will terminate the warranty obligation to the purchaser.

In addition, tampering with fuel system which alters emission-related equipment on engines may result in fines or other penalties, per EPA regulations or other local emission laws.

Do not attempt to service injection pump or fuel injectors yourself. Special training and special tools are required. (See your authorized servicing dealer).

Troubleshooting

General Troubleshooting Information

Troubleshooting engine problems can be difficult.

In this section is a list of possible engine problems that may be encountered accompanied by possible causes and corrections. The illustrated diagrams and troubleshooting information are of a general nature. See your engine distributor or servicing dealer if you are in doubt.

A reliable program for troubleshooting engine problems should include the following basic diagnostic thought process:

- Know the engine and all related systems.
- Study the problem thoroughly.
- Relate the symptoms to your knowledge of engine and systems.
- Diagnose the problem starting with the easiest things first.
- Double-check before beginning the disassembly.
- Determine cause and make a thorough repair.
- After making repairs, operate the engine under normal conditions to verify that the problem and cause was corrected.

NOTE: The engines covered in this manual have electronic control systems which send diagnostic trouble codes to signal problems.

Precautions For Welding On Engines Equipped With Electronic Engine Control Unit (ECU)

IMPORTANT: ALWAYS disconnect Electronic Control Unit (ECU) connectors and engine control system-to-machine ground before welding on engine or machine. High currents or electro-static discharge in electronic components from welding may cause permanent damage.

1. Remove the ground connection for the engine control system-to-machine frame.
2. Disconnect the connectors from the ECU.
3. Connect the welder ground close to the welding point and be sure ECU or other electronic components are not in the ground path.

Symptom	Problem	Solution
Engine cranks but will not start	Incorrect starting procedure.	Verify correct starting procedure.
	No fuel.	Check fuel in tank.
	Exhaust restricted.	Check and correct exhaust restriction.
	Fuel filter plugged or full of water.	Replace fuel filter or drain water from filter.
	Injection pump not getting fuel or air in fuel system.	Check fuel flow at supply pump or bleed system.
Engine hard to start or will not start	Engine starting under load.	Disengage PTO
	Improper starting procedure.	Review starting procedure.
	No fuel.	Check fuel tank.
	Air in fuel line.	Bleed fuel line.
	Cold weather.	Use cold weather starting aids.
	Slow starter speed.	See "Starter Cranks Slowly".
	Crankcase oil too heavy.	Use oil of proper viscosity.
	Improper type of fuel.	Consult fuel supplier; use proper type fuel for operating conditions.
	Water, dirt, or air in fuel system.	Drain, flush, fill, and bleed system.
	Clogged fuel filter.	Replace filter element.
	Dirty or faulty injection nozzles.	Have authorized servicing dealer or engine distributor check injectors.
Electronic fuel system problem if equipped)	See your distributor or servicing dealer.	
Engine knocks	Low engine oil level.	Add oil to engine crankcase.
	Low coolant temperature.	Remove and check thermostat.
	Engine overheating.	See "Engine Overheats".
	Engine cold	Wrong or defective thermostat. Remove and check thermostat.

Symptom	Problem	Solution
Engine runs irregularly or stalls frequently	Low coolant temperature.	Remove and check thermostat.
	Clogged fuel filter.	Replace fuel filter element.
	Water, dirt, or air in fuel system.	Drain, flush, fill, and bleed system. Dirty or faulty injection nozzles. Have authorized servicing dealer check injectors.
	Electronic fuel system problem	See your distributor or servicing dealer.
Below normal Engine temperature	Defective thermostat.	Remove and check thermostat.
	Defective temperature gauge or sender.	Check gauge, sender, and connections.
Lack of power	Engine overloaded.	Reduce load.
	Intake air restriction.	Service air cleaner.
	Clogged fuel filter.	Replace filter elements.
	Improper type of fuel.	Use proper fuel.
	Overheated engine.	See "Engine Overheats".
	Below normal engine temperature.	Remove and check thermostat.
	Improper valve clearance.	See your authorized servicing dealer.
	Dirty or faulty injection nozzles.	Have authorized servicing dealer check injectors.
	Injection pump out of time.	See your authorized servicing dealer.
	Electronic fuel system problem	See your authorized servicing dealer.
	Turbocharger not functioning. (Turbocharger engines only)	See your authorized servicing dealer.
	Leaking exhaust manifold gasket.	See your authorized servicing dealer.
	Defective aneroid control line.	See your authorized servicing dealer.
	Restricted fuel hose.	Clean or replace fuel hose.
Low fast idle speed.	See your authorized servicing dealer.	

Symptom	Problem	Solution
Low oil pressure	Low oil level.	Add oil.
	Improper type of oil.	Drain, fill crankcase with oil of proper Viscosity and quality.
High oil consumption	Crankcase oil too light.	Use proper viscosity oil.
	Oil leaks.	Check for leaks in lines, gaskets, and drain plug.
	Restricted crankcase vent tube.	Clean vent tube.
	Defective turbocharger.	See your authorized servicing dealer.
Engine emits white smoke	Improper type of fuel.	Use proper fuel.
	Low engine temperature.	Warm up engine to normal operating temperature.
	Defective thermostat.	Remove and check thermostat.
	Defective injection nozzles.	See your authorized servicing dealer.
Engine emits black or gray exhaust smoke	Improper type of fuel.	Use proper fuel.
	Clogged or dirty air cleaner.	Service air cleaner.
	Engine overloaded.	Reduce load.
	Injection nozzles dirty.	See your authorized servicing dealer.
	Electronic fuel system problem	See your authorized servicing dealer.
	Turbocharger not functioning.	See your authorized servicing dealer.

Symptom	Problem	Solution
Engine overheats	Engine overloaded.	Reduce load.
	Low coolant level.	Fill radiator to proper level, check radiator and hoses for loose connections or leaks.
	Faulty radiator cap.	Have technician check.
	Stretched poly-vee belt or defective belt tensioner.	Check automatic belt tensioner and check belts for stretching. Replace as required.
	Low engine oil level.	Check oil level. Add oil as required.
	Cooling system needs flushing.	Flush cooling system.
	Defective thermostat.	Remove and check thermostat.
	Defective temperature gauge or sender.	Check coolant temperature with thermometer and replace, if necessary.
	Incorrect grade of fuel.	Use correct grade of fuel.
High fuel consumption	Improper type of fuel.	Use proper type of fuel.
	Clogged or dirty air cleaner.	Service air cleaner.
	Engine overloaded.	Reduce load.
	Improper valve clearance.	See your authorized servicing dealer.
	Injection nozzles dirty.	See your authorized servicing dealer.
	Electronic fuel system problem.	See your authorized servicing dealer.
	Defective turbocharger.	See your authorized servicing dealer
	Low engine temperature.	Check thermostat.
Undercharged electrical system	Excessive electrical load from added accessories.	Remove accessories or install higher output alternator.
	Excessive engine idling.	Increase engine rpm when heavy electrical load is used.
	Poor electrical connections on battery, ground strap, starter, or alternator.	Inspect and clean as necessary.
	Defective battery.	Test battery.
	Defective alternator.	Test charging system.

Symptom	Problem	Solution
Battery uses too much Water	Cracked battery case.	Check for moisture and replace as necessary.
	Defective battery.	Test battery.
	Battery charging rate too high.	Test charging system.
Batteries will not charge	Loose or corroded connections.	Clean and tighten connections.
	Sulfated or worn-out batteries.	See your authorized servicing dealer.
	Stretched poly-vee belt or defective belt tensioner.	Adjust belt tension or replace belts.
Starter will not crank	PTO engaged.	Disengage PTO.
	Loose or corroded connections.	Clean and tighten loose connections.
	Low battery output voltage.	See your authorized servicing dealer.
	Faulty start circuit relay.	See your authorized servicing dealer.
	Blown fuse	Replace fuse.
Starter cranks slowly	Low battery output.	See your authorized servicing dealer.
	Crankcase oil too heavy.	Use proper viscosity oil.
	Loose or corroded connections.	Clean and tighten loose connections.
Entire electrical system does not function	Faulty battery connection.	Clean and tighten connections.
	Sulfated or worn-out batteries.	See your authorized servicing dealer.

Displaying Of Diagnostic Trouble Codes (DTCs)

Stored and active diagnostic trouble codes are output on the instrument panel according to the J1939 standard as a two-part code as shown on the tables in the Operating Instruction Section.

NOTE: The electronic instrument panel can have communication problems that result in Error Codes being shown on its LCD display window.

The following Error Codes all indicate that there is a communication error with the ECU.

Contact your servicing dealer for help in correcting these codes:

EE—Error	XXXXX—EP
	No Data
ACP—Err	XXXXX—BO
No Addr	No Data
ACP—Err	XXXXX—BR
BUS—EP	No Data

Intermittent Fault Diagnostics (With Electronic Controls)

Intermittent faults are problems that periodically “go away”. A problem such as a terminal that intermittently doesn’t make contact can cause an intermittent fault. Other intermittent may be set only under certain operating conditions such as heavy load, extended idle, etc. When diagnosing intermittent faults, take special note of the condition of wiring and connectors, since a high percentage of intermittent problems originate here. Check for loose, dirty or disconnected connectors. Inspect the wiring routing, looking for possible shorts caused by contact with external parts (for example, rubbing against sharp sheet metal edges). Inspect the connector vicinity, looking for wires that have pulled out of connectors, poorly positioned terminals, damaged connectors and corroded or damaged splices and terminals. Look for broken wires, damaged splices, and wire-to-wire shorts. Use good judgement if component replacement is thought to be required.

NOTE: The engine control unit (ECU) is the component LEAST likely to fail.

Suggestions for diagnosing intermittent faults:

- If the problem is intermittent, try to reproduce the operating conditions that were present when the diagnostic trouble code (DTC) set.

Observing these values can help determine the operating conditions when the fault occurred.

- If a faulty connection or wire is suspected to be the cause of the intermittent problem: clear DTCs, then check the connection or wire by wiggling it while watching the diagnostic gauge to see if the fault resets.

Possible causes of intermittent faults:

- Faulty connection between sensor and actuator harness.
- Faulty contact between terminals in connector.
- Faulty terminal/wire connection.
- Electromagnetic interference (EMI) from an improperly installed 2-way radio, etc., can cause faulty signals to be sent to the ECU.

Storage

Engine Storage Guidelines

1. Engines can be stored outside for up to three (3) months with no long term preparation IF COVERED BY WATERPROOF COVERING.
2. Engines can be stored in a standard overseas shipping container for up to three (3) months with no long term preparation.

3. Engines can be stored inside, warehoused, for up to six (6) months with no long term preparation.

Engines expected to be stored more than six (6) months, long term storage preparation MUST BE taken.

Preparing Engine for Long Term Storage

The following storage preparations are good for long term engine storage up to one year. After that, the engine should be started, warmed up, and retreated for an extended storage period.

IMPORTANT: Any time your engine will not be used for over six (6) months, the following recommendations for storing it and removing it from storage will help to minimize corrosion and deterioration.

1. Change engine oil and replace filter. Used oil will not give adequate protection.
2. Service air cleaner.
3. Draining and flushing of cooling system is not necessary if engine is to be stored only for several months. However, for extended storage periods of a year or longer, it is recommended that the cooling system be drained, flushed, and refilled. Refill with appropriate coolant.
4. Crank the engine several revolutions with starter (do not allow the engine to start).
5. Remove fan/alternator poly-vee belt, if desired.
6. Remove and clean batteries. Store them in a cool, dry place and keep them fully charged.
7. Disengage the clutch for any driveline.
8. Clean the exterior of the engine with salt-free water and touchup any scratched or chipped painted surfaces with a good quality paint.
9. Coat all exposed (machined) metal surfaces with grease or corrosion inhibitor if not feasible to paint.
10. Seal all openings on engine with plastic bags and tape.
11. Store the engine in a dry protected place. If engine must be stored outside, cover it with a waterproof canvas or other suitable protective material and use a strong waterproof tape.

Removing Engine from Long Term Storage

Refer to the appropriate section for detailed services listed below or have your authorized servicing dealer or engine distributor perform services that you may not be familiar with.

1. Remove all protective coverings from engine. Unseal all openings in engine and remove covering from electrical systems.
2. Remove the batteries from storage. Install batteries (fully charged) and connect the terminals.
3. Install fan/alternator poly-vee belt if removed.
4. Fill fuel tank.
5. Perform all appropriate pre-starting checks.

IMPORTANT: DO NOT operate starter more than 30 seconds at a time. Wait at least 2 minutes for starter to cool before trying again.

6. Crank engine for 20 seconds with starter (do not allow the engine to start). Wait 2 minutes and crank engine an additional 20 seconds to assure bearing surfaces are adequately lubricated.
7. Start engine and run at low idle and no load for several minutes. Warm up carefully and check all gauges before placing engine under load.
8. On the first day of operation after storage, check overall engine for leaks and check all gauges for correct operation.

Specifications

General Engine Specifications

ITEM	6IRF8TE
Number of Cylinders	6
Bore	106 mm (4.19 in.)
Stroke	127 mm (5.0 in.)
Displacement	6.8 L (414 cu in.)
Compression Ratio	17.0:1
Aspiration	Turbocharged
Engine Firing Order	1-5-3-6-2-4
Valves Per Cylinder	1 Intake 1 Exhaust
Valve Clearance (Cold)	
Intake (Checking)	0.31-0.38 mm (0.012-0.015 in)
Exhaust (Checking)	0.41-0.48 mm (0.016-0.019 in)
Intake (Adjusting)	0.36 mm (0.014 in.)
Exhaust (Adjusting)	0.46 mm (0.018 in.)
Max. Crank Pressure	0.5 kPa (2 H ₂ O)
Vibration Damper Maximum Radial Runout	1.50 mm (0.060 in.)
Governor Regulation (Industrial)	7-10 %
Thermostat Start To Open Temperature	82° C (180° F)
Thermostat Fully Open Temperature	94° (202° F)
Oil Pressure At Rated Speed, Full Load (± 15 psi)	345 kPa (50 psi)
Oil Pressure At Low Idle (Minimum)	105 kPa (15 psi)
Length	1116 mm (43.9 in.)
Width	623 mm (24.5 in.)
Height	1012 mm (39.9 in.)
Weight	587 kg (1290 lb)

Engine Crankcase Oil Fill Quantities

6IRF8TE
Crankcase Oil Capacity L (qt) 19.5 (20.6)

General Engine Specifications

ITEM	4IRD5AE
------	---------

Number of Cylinders	4
Bore	106 mm (4.19 in.)
Stroke	127 mm (5.0 in.)
Displacement	4.5 L (276 cu in.)
Compression Ratio	17.0:1
Aspiration	Turbocharged
Engine Firing Order	1–3–4–2
Valves Per Cylinder	1 Intake 1 Exhaust
Valve Clearance (Cold)	
Intake (Checking)	0.31–0.38 mm (0.012–0.015 in.)
Exhaust (Checking)	0.41–0.48 mm (0.016–0.019 in.)
Intake (Adjusting)	0.36 mm (0.014 in.)
Exhaust (Adjusting)	0.46 mm (0.018 in.)
Max. Crank Pressure	0.5 kPa (2 H ₂ O)
Vibration Damper Maximum Radial Runout	1.50 mm (0.060 in.)
Governor Regulation (Industrial)	7–10 %
Thermostat Start To Open Temperature	82°C (180°F)
Thermostat Fully Open Temperature	94° (202°F)
Oil Pressure At Rated Speed, Full Load (± 15 psi)	345 kPa (50 psi)
Oil Pressure At Low Idle (Minimum)	105 kPa (15 psi)
Length	860 mm (33.9 in.)
Width	612 mm (24.1 in.)
Height	994 mm (39.1 in.)
Weight	451 kg (993 lb)

Engine Crankcase Oil Fill Quantities

4IRD5AE
Crankcase Oil Capacity L (qt) 13.5 (14.3)

Lubrication and Maintenance Records

Using Lubrication and Maintenance Records

Refer to specific Lubrication and Maintenance Section for detailed service procedures.

1. Keep a record of the number of hours you operate your engine by regular observation of hour meter.
2. Check your record regularly to learn when your engine needs service.
3. DO ALL the services within an interval section. Write the number of hours (from your service Records) and the date in the spaces provided. For a complete listing of all items to be performed and the service intervals required, see chart earlier in this manual.

Emission System Warranty

U.S. EPA Emissions Control Warranty Statement

Emissions control–related parts and components are warranted for five years or 3000 hours of operation, whichever occurs first. Further, the engine covered by this warranty was designed, built, and equipped so as to conform at the time of sale with all U.S. emissions standards at the time of manufacture, and that it is free of defects in materials and workmanship which would cause it not to meet these standards within the period of five years or 3000 hours of operation, whichever occurs first.

Warranties stated in this manual refer only to emissions–related parts and components of your engine.

Emissions Control System Certification Label

CAUTION: Statutes providing severe penalties for tampering with emissions controls may apply to the user or dealer.

The emissions warranty applies only to those engines marketed by John Deere that have been certified by the United States Environmental Protection Agency (EPA) and/or California Air Resources Board (CARB); and used in the United States and Canada in non–road mobile (self–propelled or portable/transportable¹) equipment. The presence of an emissions labels signifies that the engine has been certified with the EPA and/or CARB.

The EPA and CARB warranties only apply to new engines having the certification label affixed to the engine and sold as stated above in the geographic areas. The presence of an EU number in the third line of the label signifies that the engine has been certified with the European Union countries per Directive 97/68/EC. The emissions warranty does not apply to the EU countries.

NOTE: The hp/kW rating on the engine emissions certification label specifies the gross engine hp/kW, which is flywheel power without fan. In most applications this will not be the same rating as the advertised vehicle hp/kW rating.

MAINTENANCE

	Initial 500 miles /850 km	Daily	Weekly	Monthly	3 Monthly. 250 hrs.	6 Monthly. 500 hrs	12 Monthly. 1000 hrs
Compressor Oil Level		C					
Engine Oil Level		C					
*Radiator Coolant Level		C					
Gauges/Lamps		C					
*Air Cleaner Service Indicators		C					
Fuel Tank (Fill at end of day)		C				D	
*Fuel/Water Separator Drain		C					
Oil Leaks		C					
Fuel Leaks		C					
Drain Water From Fuel Filters		D					
Coolant Leaks		C					
Radiator Filler Cap		C					
Air Cleaner Precleaner Dumps			C				
Fan/Alternator Belts			C				
Battery Connections/Electrolyte			C				
Tire Pressure and Surface			C				
*Wheel Lug Nuts				C			
Hoses (Oil, Air, Intake, etc.)				C			
Automatic Shutdown System				C			
Air Cleaner System				C			
Compressor Oil Cooler Exterior				C			
*Engine Rad/Oil Cooler Exterior				C			
Fasteners, Guards					C		
Air Cleaner Elements						R/WI	

*Disregard if not appropriate for this particular machine.

(1) or 3000 miles/5000km whichever is the sooner

(2) or as defined by local or national legislation

C = Check (adjust, clean or replace as necessary)

CBT =check before towing.

CR = Check and report

D = Drain

G = Grease

R=Replace

T = Test

W I =or when indicated if earlier.

Refer to specific sections of the operator's manual for more information.

	Initial 500 miles /850 km	Daily	Weekly	Monthly	3 Monthly. 250 hrs.	6 Monthly. 500 hrs	12 Monthly. 1000 hrs	18 Monthly. 1500 hrs
*Fuel/Water Separator Element						R		
Compressor Oil Filter Element						R		
Compressor Oil						R		
Engine Oil Change						R		
Engine Oil Filter						R		
*Water Pump Grease.							R	
*Wheels (Bearings, Seals, etc.)						C		
*Engine Coolant						C	R	
Fuel Filter Element						R		
*Injection Nozzle Check								C
Shutdown Switch Settings							T	
Scavenger Orifice & Related Parts							C	
Oil Separator Element							R	
*Feed Pump Strainer Cleaning.							C	
Coolant Replacement							R	
*Valve Clearance Check							C	
Lights (running, brake, & turn)		CBT						
Pintle Eye Bolts		CBT						
*Brakes	C				C			
*Brake linkage	C							
Emergency stop		T						
Fasteners		C						
Running gear linkage				G				
Safety valve					C			
Running gear bolts(1)					C			

*Disregard if not appropriate for this particular machine.

(1) or 3000 miles/5000km whichever is the sooner

(2) or as defined by local or national legislation

C = Check (adjust, clean or replace as necessary)

CBT =check before towing.

CR = Check and report

D = Drain

G = Grease

R=Replace

T = Test

W I =or when indicated if earlier.

Refer to specific sections of the operator's manual for more information.

	Initial 500 miles /850 km	Daily	Weekly	Monthly	3 Monthly. 250 hrs.	6 Monthly. 500 hrs	12 Monthly. 1000 hrs
Scavenge line						C	
Pressure system						C	
Engine breather element							C
Pressure gauge							C
Pressure regulator							C
Separator tank (2) exterior							CR
Lubricator (Fill)		C					

	2 Yrs	4 Yrs	6 Yrs				
Safety valve	C						
Hoses		R					
Separator tank (2) interior			C				

*Disregard if not appropriate for this particular machine.

(1) or 3000 miles/5000km whichever is the sooner

(2) or as defined by local or national legislation

C = Check (adjust, clean or replace as necessary)

CBT =check before towing.

CR = Check and report

D = Drain

G = Grease

R=Replace

T = Test

W I =or when indicated if earlier.

Refer to specific sections of the operator's manual for more information.

ROUTINE MAINTENANCE

This section refers to the various components which require periodic maintenance and replacement.

The *SERVICE/MAINTENANCE CHART* indicates the various components' descriptions and the intervals when maintenance has to take place. Oil capacities, etc., can be found in the *GENERAL INFORMATION* section of this manual.

For any specification or specific requirement on service or preventative maintenance for the engine, refer to the *Engine Manufacturer's Manual*.

Compressed air can be dangerous if incorrectly handled. Before doing any work on the unit, ensure that all pressure is vented from the system and that the machine cannot be started accidentally.

If the automatic blowdown fails to operate, then pressure must be gradually relieved by operating the manual blowdown valve. Suitable personal protective equipment should be worn.

Ensure that maintenance personnel are adequately trained, competent and have read the Maintenance Manuals.

Prior to attempting any maintenance work, ensure that:-

- all air pressure is fully discharged and isolated from the system. If the automatic blowdown valve is used for this purpose, then allow enough time for it to complete the operation.

- the discharge pipe / manifold area is depressurised by opening the discharge valve, whilst keeping clear of any airflow from it.

MINIMUM PRESSURE VALVE – WHEN FITTED
<p>NOTE: Pressure will always remain in the part of the system between the minimum pressure valve and the discharge valve after operation of the auto blowdown valve.</p> <p>This pressure must be relieved by carefully:</p> <p>(a) Disconnecting any downstream equipment.</p> <p>(b) Opening the discharge valve to atmosphere.</p> <p>(Use hearing protection if necessary).</p>

- the machine cannot be started accidentally or otherwise, by posting warning signs and/or fitting appropriate anti-start devices.

- all residual electrical power sources (mains and battery) are isolated.

Prior to opening or removing panels or covers to work inside a machine, ensure that:-

. anyone entering the machine is aware of the reduced level of protection and the additional hazards, including hot surfaces and intermittently moving parts.

. the machine cannot be started accidentally or otherwise, by posting warning signs and/or fitting appropriate anti-start devices.

Prior to attempting any maintenance work on a running machine, ensure that:–

. the work carried out is limited to only those tasks which require the machine to run.

. the work carried out with safety protection devices disabled or removed is limited to only those tasks which require the machine to be running with safety protection devices disabled or removed.

. all hazards present are known (e.g. pressurised components, electrically live components, removed panels, covers and guards, extreme temperatures, inflow and outflow of air, intermittently moving parts, safety valve discharge etc.).

. appropriate personal protective equipment is worn.

. loose clothing, jewellery, long hair etc. is made safe.

. warning signs indicating that *Maintenance Work is in Progress* are posted in a position that can be clearly seen.

Upon completion of maintenance tasks and prior to returning the machine into service, ensure that:–

. the machine is suitably tested.

. all guards and safety protection devices are refitted.

. all panels are replaced, canopy and doors closed.

. hazardous materials are effectively contained and disposed of.

PROTECTIVE SHUTDOWN SYSTEM

Refer to the Wedge diagnostic display codes table for a listing of shutdown conditions.

Low engine fuel level switch.

At three month intervals, test the low engine fuel level switch circuit as follows:

. Start the machine.

Note: Do not press the load button.

. Disconnect the switch, the machine should shutdown.

. Re-connect the switch.

At twelve month intervals, test the low engine fuel level switch by removing and operating the float manually.

CAUTION: Never remove or replace switches when the machine is running.

SCAVENGE LINE

The scavenge line runs from the combined orifice/drop tube in the separator tank, to the orifice fitting located in the airend.

Examine the orifice, check valve and hoses at every service or in the event of oil carryover into the discharge air.

It is good preventative maintenance to check that the scavenge line and tube are clear of any obstruction each time the compressor lubricant is changed as any blockage will result in oil carryover into the discharge air.

COMPRESSOR OIL FILTER

Refer to the *MAINTENANCE CHART* in this section for the recommended servicing intervals.

Removal

WARNING: Do not remove the filter(s) without first making sure that the machine is stopped and the system has been completely relieved of all air pressure. (Refer to *STOPPING THE UNIT* in the *OPERATING INSTRUCTIONS* section of this manual).

Clean the exterior of the filter housing and remove the *spin-on* element by turning it in a counter-clockwise direction.

Inspection

Examine the filter element.

CAUTION: If there is any indication of the formation of varnishes, shellacs or lacquers on the filter element, it is a warning that the compressor lubricating and cooling oil has deteriorated and that it should be changed immediately. Refer to *LUBRICATION* later in this section.

Reassembly

Clean the filter gasket contact area and install the new element by screwing in a clockwise direction until the gasket makes contact with the filter housing. Tighten a further $\frac{1}{2}$ to $\frac{3}{4}$ of a revolution.

CAUTION: Start the machine (refer to *PRIOR TO STARTING* and *STARTING THE UNIT* in the *OPERATING INSTRUCTIONS* section of this manual) and check for leakage before the machine is put back into service.

COMPRESSOR OIL SEPARATOR ELEMENT

Normally the separator element will not require periodic maintenance provided that the air and oil filter elements are correctly maintained.

If, however, the element has to be replaced, then proceed as follows:

Removal

WARNING: Do not remove the filter(s) without first making sure that the machine is stopped and the system has been completely relieved of all air pressure. (Refer to *STOPPING THE UNIT* in the *OPERATING INSTRUCTIONS* section of this manual).

Disconnect all hoses and tubes from the separator tank cover plate. Remove the drop-tube from the separator tank cover plate and then remove the cover plate. Remove the separator element.

Inspection

Examine the filter element. Examine all hoses and tubes, and replace if necessary.

Reassembly

Thoroughly clean the orifice/drop tube and filter gasket contact area before reassembly. Install the new element.

WARNING

Do not remove the staple from the anti-static gasket on the separator element since it serves to ground any possible static build-up. Do not use gasket sealant since this will affect electrical conductance.

Reposition the cover plate, taking care not to damage the gasket, and replace the cover plate screws tightening in a criss-cross pattern to the recommended torque (refer to the *TORQUE SETTING TABLE* later in this section).

Engage the adaptor in the cover plate with the drop-tube integral with the filter, reconnect all hoses and tubes to the separator tank cover plate.

Replace the compressor oil (refer to *LUBRICATION* later in this section).

CAUTION: Start the machine (refer to *PRIOR TO STARTING* and *STARTING THE UNIT* in the *OPERATING INSTRUCTIONS* section of this manual) and check for leakage before the machine is put back into service.

COMPRESSOR OIL COOLER AND ENGINE RADIATOR

When grease, oil and dirt accumulate on the exterior surfaces of the oil cooler and radiator, the efficiency is impaired. It is recommended that each month the oil cooler and radiator be cleaned by directing a jet of compressed air, (carrying if possible a non-flammable cleaning solvent) over the exterior core of the cooler/radiator. This should remove any accumulation of oil, grease and dirt from the exterior core of the cooler so that the entire cooling area can radiate the heat of the lubricating and cooling oil/water into the air stream.

WARNING: Hot engine coolant and steam can cause injury. When adding coolant or antifreeze solution to the engine radiator, stop the engine at least one minute prior to releasing the radiator filler cap. Using a cloth to protect the hand, slowly release the filler cap, absorbing any released fluid with the cloth. Do not remove the filler cap until all excess fluid is released and the engine cooling system fully depressurised.

WARNING: Follow the instructions provided by the antifreeze supplier when adding or draining the antifreeze solution. It is advisable to wear personal protective equipment to prevent skin and eye contact with the antifreeze solution.

7/120 (P425AWIR), 9/110 (XP375AWIR), 10/105 (HP375AWIR), 14/85 (VHP300AWIR), 7/170 (P600WIR), 10/125 (HP450WIR), 14/115 (VHP400WIR)

AIR FILTER ELEMENTS

The air filter should be inspected regularly (refer to the *SERVICE/MAINTENANCE CHART*) and the element replaced when the restriction indicator shows red or every 6 Months (500 hours), whichever comes first. The dust collector box(es) should be cleaned daily (more frequently in dusty operating conditions) and not allowed to become more than half full.

Removal

CAUTION: Never remove and replace element(s) when the machine is running.

Clean the exterior of the filter housing and remove the filter element by releasing the nut.

Inspection

Check for cracks, holes or any other damage to the element by holding it up to a light source, or by passing a lamp inside.

Check the seal at the end of the element and replace if any sign of damage is evident.

Reassembly

Assemble the new element into the filter housing ensuring that the seal seats properly.

Reset the restriction indicator by depressing the rubber diaphragm.

Assemble the dust collector box parts, ensuring that they are correctly positioned.

Before restarting the machine, check that all clamps are tight.

VENTILATION

Always check that the air inlets and outlets are clear of debris etc.

CAUTION: NEVER clean by blowing air inwards.

COOLING FAN DRIVE

Periodically check that the fan mounting bolts in the fan hub have not loosened. If, for any reason, it becomes necessary to remove the fan or re-tighten the fan mounting bolts, apply a good grade of commercially available thread locking compound to the bolt threads and tighten to the torque value shown in the *TORQUE SETTING TABLE* later in this section.

The fan belt(s) should be checked regularly for wear and correct tensioning.

FUEL SYSTEM

The fuel tank should be filled daily or every eight hours. To minimise condensation in the fuel tank(s), it is advisable to top up after the machine is shut down or at the end of each working day. At six month intervals drain any sediment or condensate that may have accumulated in the tank(s).

FUEL FILTER WATER SEPARATOR

The fuel filter water separator contains a filter element which should be replaced at regular intervals (see the *SERVICE/MAINTENANCE CHART*).

CHARGE AIR COOLER PIPEWORK

Inspect all hoses and clips on the charge cooler pipe work.

Engine damage will occur if the charge cooling system leaks.

HOSES

All components of the engine cooling air intake system should be checked periodically to keep the engine at peak efficiency.

At the recommended intervals, (see the *SERVICE/MAINTENANCE CHART*), inspect all of the intake lines to the air filter, and all flexible hoses used for air lines, oil lines and fuel lines.

Periodically inspect all pipework for cracks, leaks, etc. and replace immediately if damaged.

ELECTRICAL SYSTEM

WARNING: Always disconnect the battery cables before performing any maintenance or service.

Inspect the safety shutdown system switches and the instrument panel relay contacts for evidence of arcing and pitting. Clean where necessary.

Check the mechanical action of the components.

Check the security of electrical terminals on the switches and relays i.e. nuts or screws loose, which may cause local hot spot oxidation.

Inspect the components and wiring for signs of overheating i.e. discolouration, charring of cables, deformation of parts, acrid smells and blistered paint.

BATTERY

Keep the battery terminals and cable clamps clean and lightly coated with petroleum jelly to prevent corrosion.

The retaining clamp should be kept tight enough to prevent the battery from moving.

PRESSURE SYSTEM

At 500 hour intervals it is necessary to inspect the external surfaces of the system (from the airend through to the discharge valve(s)) including hoses, tubes, tube fittings and the separator tank, for visible signs of impact damage, excessive corrosion, abrasion, tightness and chafing. Any suspect parts should be replaced before the machine is put back into service.

TYRES/TYRE/TIRE PRESSURE

See the *GENERAL INFORMATION* section of this manual.

RUNNING GEAR/WHEELS

Check the wheel nut torque 20 miles (30 kilometres) after refitting the wheels. Refer to the *TORQUE SETTING TABLE* later in this section.

Lifting jacks should only be used under the axle.

The bolts securing the running gear to the chassis should be checked periodically for tightness (refer to the *SERVICE/MAINTENANCE CHART* for frequency) and re-tightened where necessary. Refer to the *TORQUE SETTING TABLE* later in this section.

BRAKES

Check and adjust the brake linkage at 500 miles (850Km) then every 3000 miles (5000Km) or 3 months (whichever is the sooner) to compensate for any stretch of the adjustable cables. Check and adjust the wheel brakes to compensate for wear.

CAUTION: Check the wheel nut torque 20 miles (30 kilometres) after refitting the wheels (Refer to the TORQUE SETTING TABLE later in this section).

Adjusting the overrun braking system (KNOTT Running Gear)

1: Preparation

Jack up the machine

Disengage the handbrake lever [1].

Fully extend the draw bar [2] on the overrun braking system.

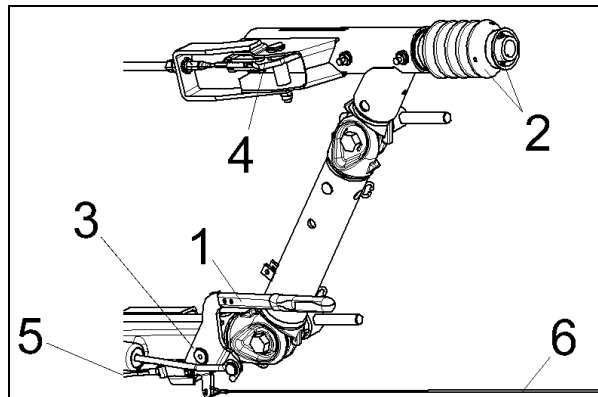

- 1 Handbrake lever
- 2 Draw bar and bellows
- 3 Handbrake lever pivot
- 4 Transmission lever
- 5 Brake cable
- 6 Breakaway Cable

Requirements:

During the adjustment procedure always start with the wheel brakes.

Always rotate the wheel in the direction of forward movement.

Ensure that an M10 safety screw is fitted to the handbrake pivot.

The brake actuators must not be pre-tensioned – if necessary loosen the brake linkage [7] on the brake equalisation assembly [8].

Check that brake actuators and cables [11] operate smoothly.

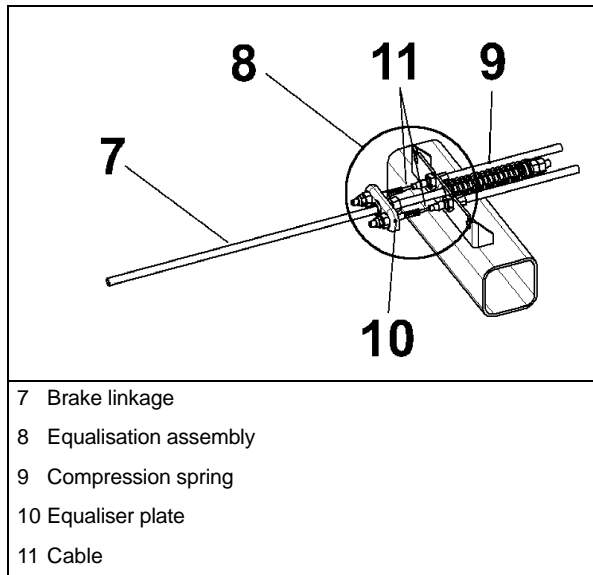

CAUTION

The compression spring [9] must only be lightly pre-tensioned and when operating must never touch the axle tube. Never adjust the brakes at the brake linkage [7].

2. Brake Shoe Adjustment

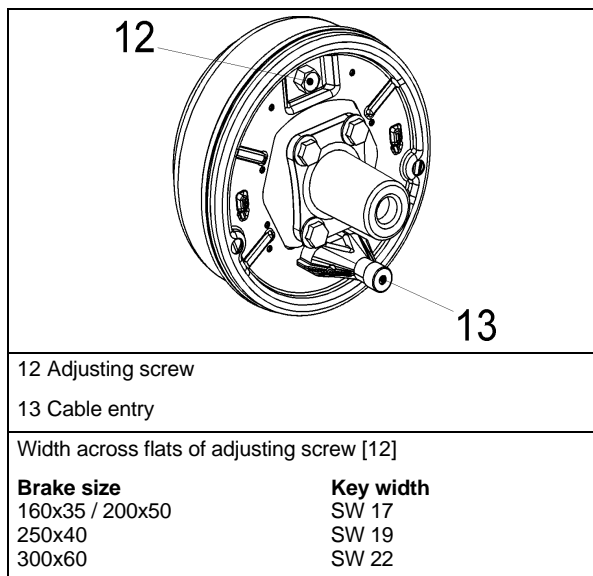

Tighten adjusting screw [12] clockwise until the wheel locks.

Loosen adjusting screw [12] anti-clockwise (approx. ½ turn) until the wheel can be moved freely.

Slight dragging noises that do not impede the free movement of the wheel are permissible.

This adjustment procedure must be carried out as described on both wheel brakes.

When the brake has been adjusted accurately the actuating distance is approximately 5–8mm on the cable [11]

3: Compensator assembly adjustment

Variable Height models

Fit an M10 safety screw to the handbrake pivot.

Disconnect the handbrake cable [5] at one end.

Pre-adjust brake linkage [7] lengthways (a little play is permissible) and re-insert the cable [5], adjusting it to give a small amount of play.

Remove the M10 safety screw from the handbrake pivot.

All Models

Engage the handbrake lever [1] and check that the position of the equaliser plate [10] is at right angles to the pulling direction. If necessary correct the position of the equaliser plate [10] on the cables [11].

The compression spring [9] must only be slightly pre-tensioned and when engaged must not touch the axle tube.

4: Brake linkage adjustment

Adjust the brake linkage [7] lengthways without pre-tension and without play in the transmission lever [4].

Readjustment

Engage the handbrake lever [1] forcefully a number of times to set the brake.

Check the alignment of the equalisation assembly [8], this should be at right angles to the pulling direction

Check the play in the brake linkage [7]

If necessary adjust the brake linkage [7] again without play and without pre-tensioning

There must still be a little play in cable [5] (Variable Height Only)

Check the position of the hand brake lever [1]. The start of resistance should be approximately 10–15mm above the horizontal position.

Check that the wheels move freely when the handbrake is disengaged.

Final test

Check the fastenings on the transmission system (cables, brake equalisation system and linkage).

Check the handbrake cable [5] for a small amount of play and adjust if necessary (Variable height only)

Check the compression spring [9] for pre-tensioning.

Test run

If necessary carry out 2–3 test brake actions.

Test brake action

Check the play in brake linkage [7] and if necessary adjust the length of brake linkage [7] until there is no play.

Apply the handbrake while rolling the machine forward, travel of the handbrake lever up to 2/3 of maximum is allowed.

Re-adjusting the overrun braking system (KNOTT Running Gear)

Re-adjustment of the wheel brakes will compensate for brake lining wear. Follow the procedure described in 2: Brake Shoe Adjustment

Check the play in the brake linkage [7] and re-adjust if necessary.

Important

Check the brake actuators and cables [11]. The brake actuators must not be pre-tensioned.

Excessive operation of the handbrake lever, which may have been caused by worn brake linings, must not be corrected by re-adjusting (shortening) the brake linkage [7]

Re-adjustment

The handbrake lever [1] should be engaged forcefully several times to set the braking system.

Check the setting of the brake equalisation assembly [8], which should be at right angles to the pulling direction.

Check the play in the brake linkage [7] again, ensuring that there is no play in the brake linkage and that it is adjusted without pre-tension

Check the position of the hand brake lever [1], cable [5] (with little play) and the compression spring [9] (only slight pre-tension). The start of resistance of the handbrake lever should be approximately 10–15mm above the horizontal position.

Final test

Check the fastenings on the transmission system (cables, brake equalisation system and linkage)

Apply the handbrake while rolling the machine forward, travel of the handbrake lever up to 2/3 of maximum is allowed.

Check the handbrake cable [5] for a small amount of play and adjust if necessary (Variable height only)

Check the compression spring [9] for slight pre-tensioning.

LUBRICATION

The engine is initially supplied with engine oil sufficient for a nominal period of operation (for more information, consult the Engine section of this manual).

CAUTION: Always check the oil levels before a new machine is put into service.

If, for any reason, the unit has been drained, it must be re-filled with new oil before it is put into operation.

ENGINE LUBRICATING OIL

The engine oil should be changed at the engine manufacturer's recommended intervals. Refer to the Engine section of this manual.

ENGINE LUBRICATING OIL SPECIFICATION

Refer to the Engine section of this manual.

ENGINE OIL FILTER ELEMENT

The engine oil filter element should be changed at the engine manufacturer's recommended intervals. Refer to the Engine section of this manual.

COMPRESSOR LUBRICATING OIL

Refer to the *SERVICE/MAINTENANCE CHART* in this section for service intervals.

NOTE: If the machine has been operating under adverse conditions, or has suffered long shutdown periods, then more frequent service intervals will be required.

WARNING: DO NOT, under any circumstances, remove any drain plugs or the oil filler plug from the compressor lubricating and cooling system without first making sure that the machine is stopped and the system has been completely relieved of all air pressure (refer to *STOPPING THE UNIT* in the *OPERATING INSTRUCTIONS* section of this manual).

Completely drain the receiver/separator system including the piping and oil cooler by removing the drain plug(s) and collecting the used oil in a suitable container.

Replace the drain plug(s) ensuring that each one is secure.

NOTE: If the oil is drained immediately after the machine has been running, then most of the sediment will be in suspension and will therefore drain more readily.

CAUTION: Some oil mixtures are incompatible and result in the formation of varnishes, shellacs or lacquers which may be insoluble.

NOTE: Always specify INGERSOLL-RAND Pro-Tec™ oil for use at all ambient temperatures above -23°C.

COMPRESSOR OIL FILTER ELEMENT

Refer to the *SERVICE / MAINTENANCE CHART* in this section for service intervals.

RUNNING GEAR WHEEL BEARINGS

Wheel bearings should be packed with grease every 6 months. The type of grease used should conform to specification *MIL-G-10924*.

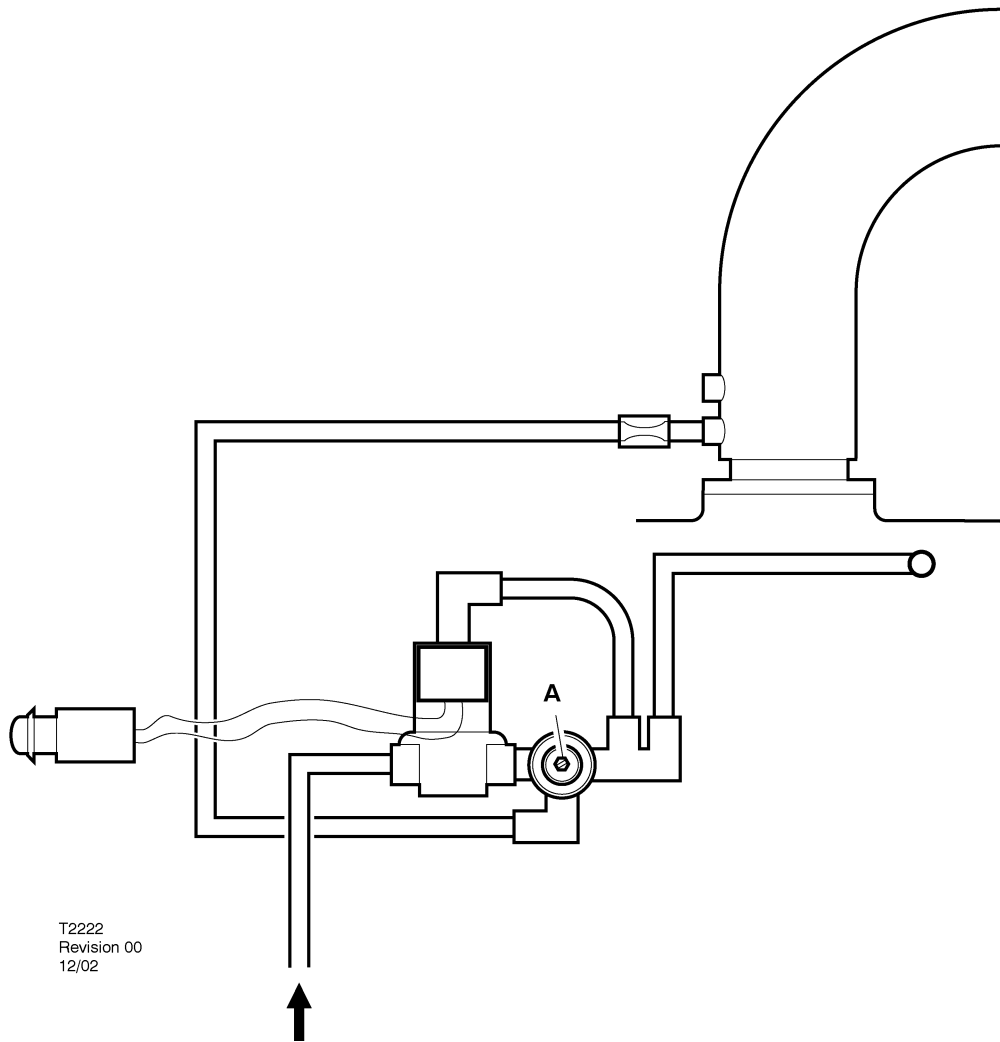

SPEED AND PRESSURE REGULATION ADJUSTMENT

Normally, regulation requires no adjusting, but if correct adjustment is lost, proceed as follows:

Refer to the diagram above.

A: Adjusting screw

Start the machine (Refer to *STARTING INSTRUCTIONS* in the *OPERATING INSTRUCTIONS* section of this manual).

Adjust the service valve on the outside of the machine to maintain rated pressure at full speed. If full speed is not maintained at rated pressure, then turn the adjusting screw clockwise to increase the pressure. Optimum adjustment is achieved when full speed is achieved at rated pressure.

Close the service valve. The engine will slow to idle speed.

TABLE 1 INCH FASTENERS

CAPSCREW OR NUT THREAD SIZE AND PITCH	NOMINAL DESIGN TORQUE			
	8AE J249 GRADE 5 (HEAD MARKING)		8AE J249 GRADE 8 (HEAD MARKING)	
	(Nm.)	(FT-LBF)	(Nm.)	(FT-LBF)
1/4 – 20	11	8	16	12
5/16 – 18	24	17	33	25
3/8 – 16	42	31	59	44
7/16 – 14	67	49	95	70
1/2 – 13	102	75	144	106
9/16 – 12	148	109	208	154
5/8 – 11	203	150	287	212
3/4 – 10	361	266	509	376

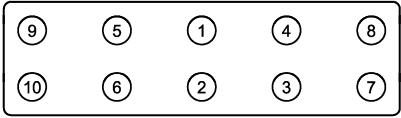

TYPICAL RECTANGULAR TORQUE PATTERN

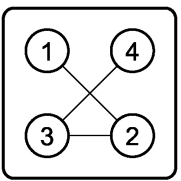



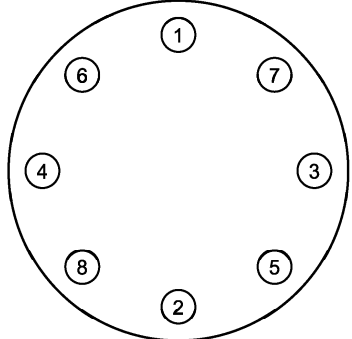





TYPICAL SQUARE TORQUE PATTERN



TYPICAL CIRCULAR TORQUE PATTERN

TABLE 2

METRIC FASTENERS

CAPSCREW OR NUT THREAD SIZE AND PITCH	NOMINAL DESIGN TORQUE					
	PROPERTY GRADE 8.8 (HEAD MARKING)		PROPERTY GRADE 10.9 (HEAD MARKING)		PROPERTY GRADE 12.9 (HEAD MARKING)	
	(Nm.)	(FT-LBF)	(Nm.)	(FT-LBF)	(Nm.)	(FT-LBF)
						
						
						
M6 X 1.0	11	8	15	11	18	13
M8 X 1.25	26	19	36	27	43	31
M10 X 1.5	52	38	72	53	84	62
M12 X 1.75	91	67	126	93	147	109
M14 X 2	145	107	200	148	234	173
M16 X 2	226	166	313	231	365	270
M20 X 2.5	441	325	610	450	713	526

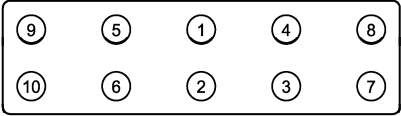

TYPICAL RECTANGULAR TORQUE PATTERN

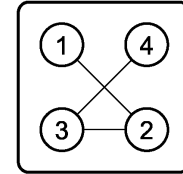

TYPICAL SQUARE TORQUE PATTERN

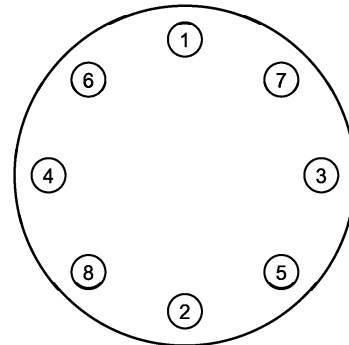

TYPICAL CIRCULAR TORQUE PATTERN

COMPRESSOR LUBRICATION

Portable Compressor Fluid Chart

Refer to these charts for correct compressor fluid required. Note that the selection of fluid is dependent on the design operating pressure of the machine and the ambient temperature expected to be encountered before the next oil change.

Design Operating Pressure	Ambient Temperature	Specification
100 psi to 300 psi	-10°F to 125°F (-23°C to 52°C)	IR Pro-Tec™ Mil -PRF 2104G SAE 10W
100 psi to 300 psi	-40°F to 125°F (-40°C to 52°C)	IR Performance 500 Mil-L-46167
350 psi	-10°F to 125°F (-23°C to 52°C) 65°F to 125°F (18°C to 52°C) -40°F to 65°F (-40°C to 18°C)	IR XHP 505 IR XHP1001 IR Performance 500 Mil-L-46167
500 psi	50°F to 125°F (10°C to 52°C) 10°F to 65°F (-12°C to 18°C) below 10°F (-12°C)	IR XHP1001 IR XHP 505 Consult Factory

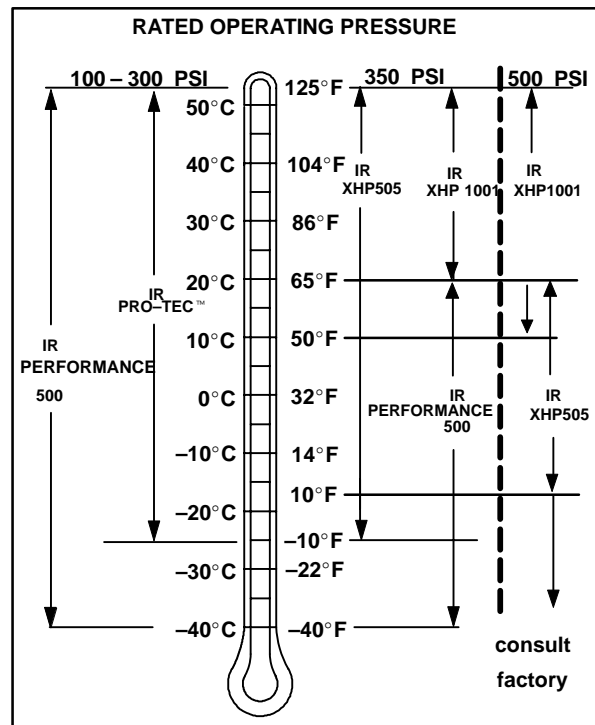

Recommended Ingersoll-Rand Fluids – Use of these fluids with original IR filters can extend airend warranty. Refer to operator's manual warranty section for details or contact your IR representative.

Compressor Recommended Fluid	1 Gal.	5 Gal.	55 Gal.	275 Gal. Tote	Europe	
					20 Litre	208 Litre
Pro-Tec™	36899698	36899706	36899714	36899722	89292973	89292981
XHP 505	NA	54418835	54418843	54418827	—	—
Performance 500	35382928	35382936	35382944	NA	—	—
XHP1001	NA	35612738	35300516	NA	—	—
Engine Oil	54480918	36875938	36866903	NA	89311716	89311724

MACHINE SYSTEMS

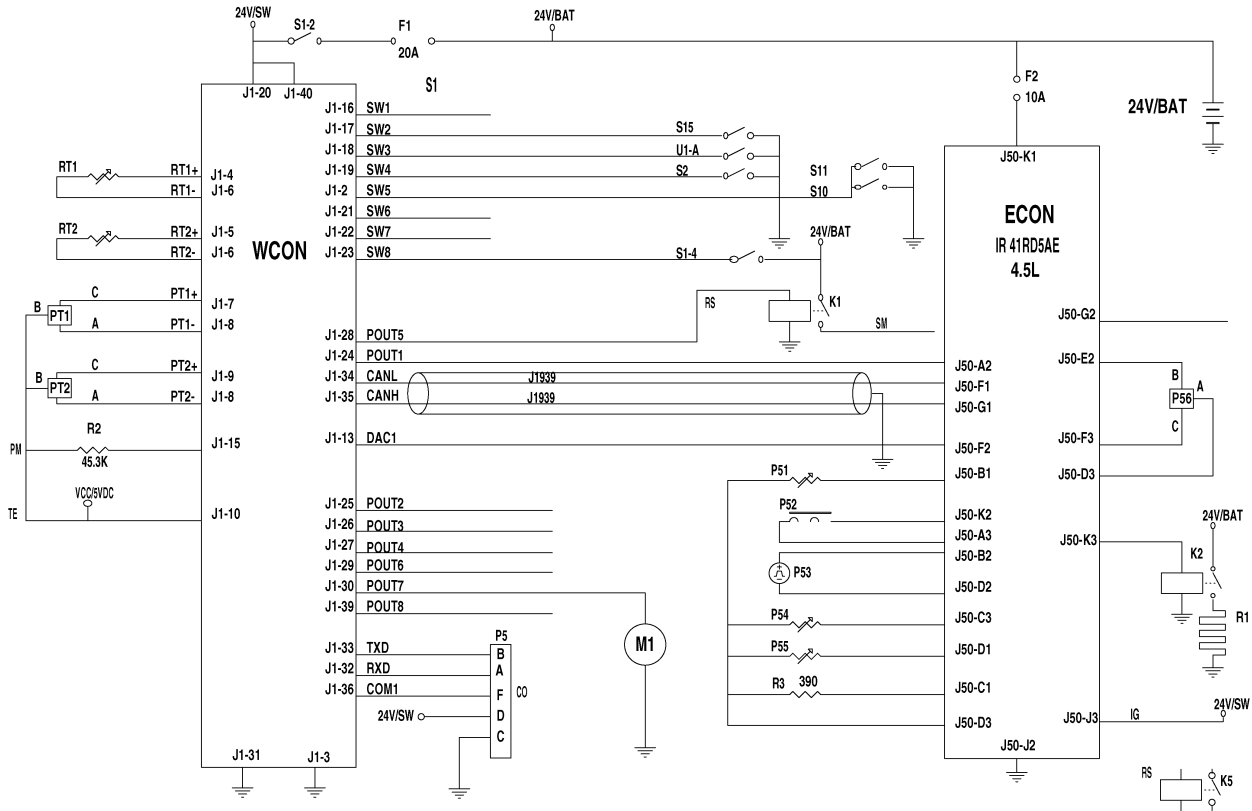

KEY

BAT	Battery	PT1	Pressure transducer, separator tank 0–500 PSIG
CO	RS232C comms	PT2	Pressure transducer, regulation system 0–100 PSIG
ECON	Engine controller	PM	Plug, machine ID
IG	Isochronous governor	R3	Idle sel
J50–G2	Wait to start lamp	RS	Relay–spst
J50–K3	Inlet heater	RT1	Thermistor, separator tank temperature –30 – 255°F
P51	Coolant temp	RT2	Thermistor, airend discharge temperature –30 – 255°F
P52	Inject	SI	Switch inputs
P53	Crank sensor	SM	Starter motor
P54	Fuel temp	SW1	Spare
P55	Manifold air temp	SW2	Display scroll
P56	Oil pressure	SW3	Low fuel shutdown
POUT1	Engine key switch	SW4	Switch, service air
POUT2	Solenoid, start/run	SW5	Air filter rest (option)
POUT3	Comp fault lamp	SW6	Spare
POUT4	Engine fault lamp	SW7	Spare
POUT5	Start relay	SW8	Switch, start
POUT6	Spare	TE	Transducer exitation
POUT7	Hour meter	WCON	Wedge controller
POUT8	Spare		

WEDGE TO ENGINE INTERFACE – IR ENGINE

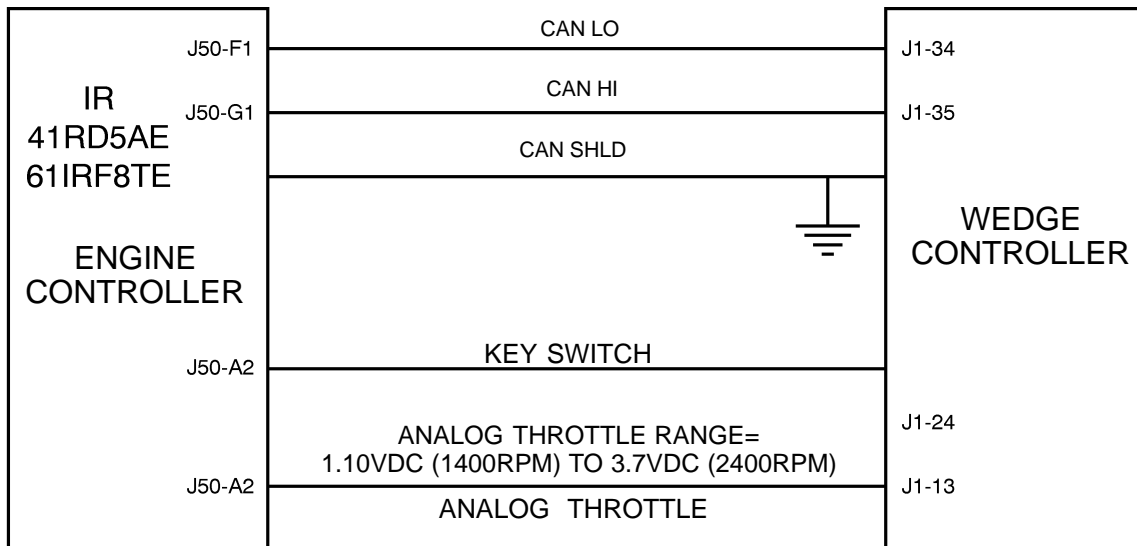

T2224
Revision 00
12/02

FIGURE 2-1

HARNESS SYSTEM SCHEMATIC

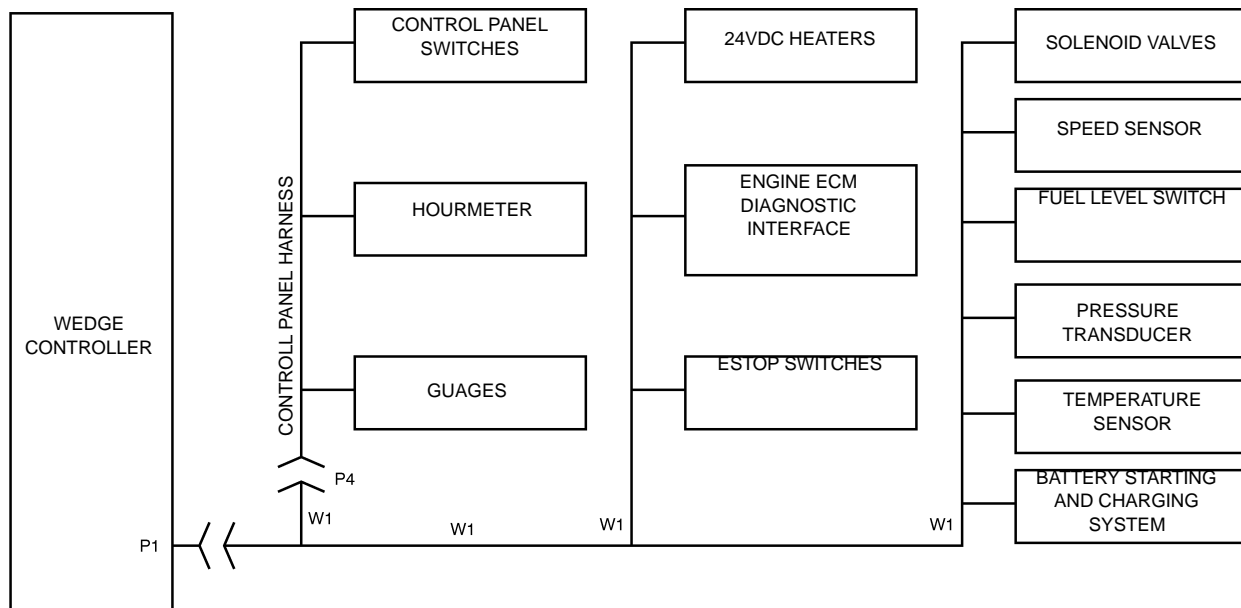

T2223
Revision 00
12/02

FIGURE 2-2

J1939 CAN COMMUNICATIONS SCHEMATIC

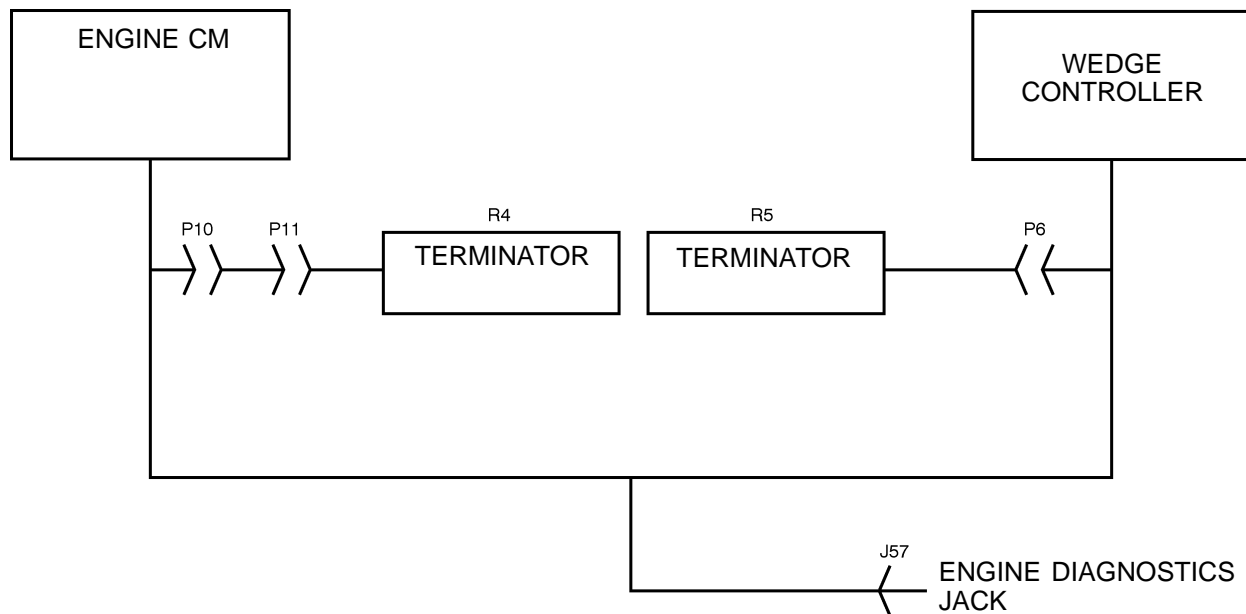

T2225
Revision 00
12/02

FIGURE 2-3

SERVICE TOOLS



Electronic Systems



The following special tools are recommended to perform service procedures in this manual.

The tools can be purchased from Ingersoll–Rand or equivalent substitutes can be used.

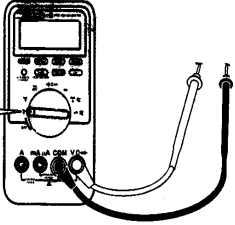
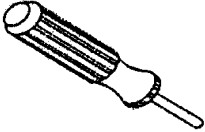
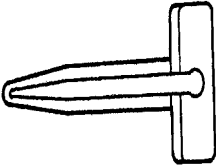
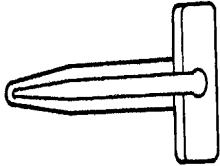
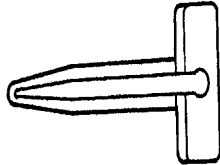
Tool	Tool Description
Fluke 87	Digital Multimeter <i>Used to Measure electrical circuits: volts, ohms amps</i>
54729660	Weather–Pack Terminal Removal Tool <i>Used to repair Packard Electric Weather–Pack Connectors</i>
54729678	Deutsch Terminal Removal Tool (Blue) <i>Used to repair Deutsch connectors</i>
54729686	Deutsch Terminal Removal Tool (Red) <i>Used to repair Deutsch connectors</i>
54729694	Deutsch Terminal Removal Tool (Yellow) <i>Used to repair Deutsch connectors</i>
HDT–48–00	Deutsch Terminal Crimp Tool <i>Used to crimp Deutsch connector terminals</i>
DD	Deutsch Terminal Crimping Tool <i>Used to crimp Deutsch connector terminals</i>
54729710	Electrical Contact Cleaner <i>Used to clean electrical contacts and connectors</i>
54729728	PDA Service Tool <i>Palm Pilot based service tool used to connect to Intellisys (SGP) Controller to load software and extract service information</i>
22073886	Packard Crimp Tool <i>Used to crimp Packard connector terminals</i>
22073878	Thermistor Simulator Plug <i>Used to test thermister circuits</i>
54699616	Deutsch Terminal Removal Tool <i>Used to repair Deutsch connectors</i>
54699657	Deutsch Terminal Removal Tool <i>Used to repair Deutsch connectors</i>
54749643	Packard Metri–Pack Terminal Removal Tool <i>Used to repair Metri–Pack connectors</i>
54749635	Connector Repair Kit <i>Used to make connector repairs</i>

SERVICE TOOLS

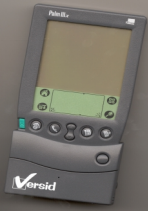
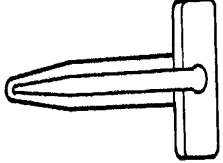
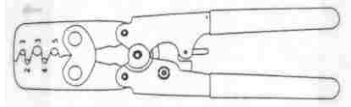
Tool No.	Tool Description	Tool Illustration
Fluke 87	<p>Digital Multimeter Available from electrical and electronic parts distributors.</p>	
54729660	<p>Weather-Pack Terminal Removal Tool</p>	
54699632	<p>Deutsch Terminal Removal Tool (Blue)</p>	
54699640	<p>Deutsch Terminal Removal Tool (Red)</p>	
54699624	<p>Deutsch Terminal Removal Tool (Yellow)</p>	
DT-RT1	<p>Crimp Tool for Deutsch Pins Crimp Available from: Ladd Industries (800-223-1236)</p>	
54729710	<p>Electrical Contact Cleaner</p>	

54729728	PDA Service Tool	
54699616	Deutsch Terminal Removal Tool	
22073886	Packard Crimp Tool	
22073878	Thermistor Simulator	
54749635	Connector Repair Kit	
54699657	Deutsch Terminal Removal Tool	
54749643	Packard Metri-Pack Removal Tool	

ELECTRICAL PARTS

PARTS NUMBERS	DESCRIPTION	QTY PER MACHINE	PARTS NUMBERS	DESCRIPTION	QTY PER MACHINE
36920825	0–100 psi PRESSURE TRANSDUCER	1	35578194	ENGINE GROUND STRAP	1
54765946	0–500 psi PRESSURE TRANSDUCER	1	54731427	FUEL LEVEL SENDER	1
36898922	THERMISTOR PROBE	2	22173579	WEDGE CONTROLLER	1
36840841	SOLENOID VALVE	1*	22199061	W1 CHASSIS HARNESS	1
36853521	STARTER AND INLET HEATER RELAY	2	22179659	W1 CHASSIS HARNESS DIAGRAM	N/A
35610856	NEGATIVE BATTERY CABLE	1	36792083	FUSE 20 AMP BLADE	1
35583582	POSITIVE BATTERY CABLE	1	22071591	FUSE 10 AMP BLADE	1
			54475777	DIAGNOSTIC SWITCH	1
			**	MACHINE ID PLUG	1

* Quantity two (2) per machine on P600WIR (7/170) model only.

** Part number 22201354 on models 7/120 (P425AWIR), 9/110 (XP375AWIR), 10/105 (HP375AWIR), and 14/85 (VHP300AWIR). Part number 22201362 on models 7/170 (P600WIR), 10/125 (HP450WIR), and 14/115 (VHP400WIR).

FAULT FINDING

FAULT	CAUSE	REMEDY
No reaction from instrument panel when key turned to (I) position.	<i>Batteries not connected.</i>	Connect batteries.
	<i>Fuse at starter motor 'blown'.</i>	Replace fuse.
Engine fails to start.	<i>Low battery charge.</i>	Check the fan belt tension, battery and cable connections.
	<i>Bad earth connection.</i>	Check the earth cables, clean as required.
	<i>Loose connection.</i>	Locate and make the connection good.
	<i>Fuel starvation.</i>	Check the fuel level and fuel system components. Replace the fuel filter if necessary.
	<i>Relay failed.</i> <i>Faulty stop solenoid</i>	Replace the relay. Check the stop solenoid
Engine stops while in service or is reluctant to start.	<i>Low fuel level.</i>	Fill fuel tank and bleed air from fuel system if necessary. (Refer to MAINTENANCE SECTION).
	<i>Safety shut-down system in operation.</i>	Check the safety shut-down switches.
Engine starts but stalls when the switch returns to position I.	<i>Electrical fault</i>	Test the electrical circuits.
	<i>Low engine oil pressure.</i>	Check the oil level and the oil filter(s).
	<i>Faulty relay</i>	Check the relays.
	<i>Faulty key-switch</i>	Check the key-switch.
Engine starts but will not run or engine shuts down prematurely.	<i>Electrical fault.</i>	Test the electrical circuits.
	<i>Low engine oil pressure.</i>	Check the oil level and oil filter(s).
Engine starts but will not run or engine shuts down prematurely.	<i>Safety shut-down system in operation.</i>	Check the safety shut-down switches.
	<i>Fuel starvation.</i>	Check the fuel level and fuel system components. Replace the fuel filter if necessary.
	<i>Switch failure.</i>	Test the switches.
	<i>High compressor oil temperature.</i>	Check the compressor oil level and oil cooler. Check the fan drive.
	<i>Water present in fuel system.</i>	Check the water separator and clean if required.
	<i>Faulty relay.</i>	Check the relays and replace if necessary.

Engine Overheats.	<i>Low water level</i>	Check the level and replenish if necessary.
	<i>Blocked radiator.</i>	Stop the machine and clean the cooling fins with compressed air or steam. Use reduced pressure for cleaning the fins.
	<i>Reduced cooling air from fan.</i>	Check the fan and the drive belts. Check for any obstruction inside the cowl.
	<i>Faulty thermostat</i>	Check the thermostat and replace if necessary.
Engine speed too high.	<i>Incorrect throttle arm setting.</i>	Check the engine speed setting.
Engine speed too low.	<i>Incorrect throttle arm setting.</i>	Check the throttle setting.
	<i>Blocked fuel filter.</i>	Check and replace if necessary.
	<i>Blocked air filter.</i>	Check and replace the element if necessary.
	<i>Incorrectly set regulation system.</i>	Reset the regulation system. Refer to SPEED AND PRESSURE REGULATION ADJUSTMENT in the MAINTENANCE section of this manual.
	<i>Premature unloading.</i>	Check the regulation system.
Excessive vibration.	<i>Engine speed too low.</i>	See "Engine speed too low"
Leaking oil seal.	<i>Improperly fitted oil seal.</i>	Replace the oil seal.
Refer also to the Engine Manufacturer's Manual.		
Air discharge capacity too low.	<i>Engine speed too low.</i>	See "Engine speed too low"
	<i>Blocked air cleaner.</i>	Check the restriction indicators and replace the element(s) if necessary.
	<i>High pressure air escaping.</i>	Check for leaks.
	<i>Incorrectly set regulation system.</i>	Reset the regulation system. Refer to SPEED AND PRESSURE REGULATION ADJUSTMENT in the MAINTENANCE section of this manual.

FAULT FINDING

Compressor overheats.	<i>Low oil level.</i>	Top up the oil level and check for leaks.
	<i>Dirty or blocked oil cooler.</i>	Clean the oil cooler fins.
	<i>Incorrect grade of oil.</i>	Use Ingersoll-Rand recommended oil.
	<i>Defective by-pass valve.</i>	Check the operation of the element and replace if necessary.
	<i>Recirculation of cooling air.</i>	Move the machine to avoid recirculation.
	<i>Reduced cooling air from fan.</i>	Check the fan and the drive belts. Check for any obstruction inside the fan cowl.
Excessive oil present in the discharge air.	<i>Blocked scavenge line.</i>	Check the scavenge line, drop tube and orifice. Clean and replace.
	<i>Perforated separator element.</i>	Replace the separator element.
	<i>Pressure in the system is too low.</i>	Check the minimum pressure valve.
Safety valve operates.	<i>Operating pressure too high.</i>	Refer to SPEED AND PRESSURE REGULATION ADJUSTMENT in the MAINTENANCE section of this manual.
	<i>Incorrect setting of the regulator.</i>	Adjust the regulator.
	<i>Faulty regulator.</i>	Replace the regulator.
	<i>Inlet valve set incorrectly.</i>	Refer to SPEED AND PRESSURE REGULATION ADJUSTMENT in the MAINTENANCE section of this manual.
	<i>Loose pipe/hose connections.</i>	Check all pipe/hose connections.
	<i>Faulty safety valve.</i>	Check the relieving pressure. Replace the safety valve if faulty. DO NOT ATTEMPT A REPAIR.

Oil is forced back into the air filter.	<i>Incorrect stopping procedure used</i>	Always employ the correct stopping procedure. Close the discharge valve and allow the machine to run on idle before stopping.
	<i>Faulty inlet valve.</i>	Check for free operation of the inlet valve(s).
Machine goes to full pressure when started.	<i>Faulty load valve.</i>	Replace the valve.
Machine fails to load when the load switch is pressed.	<i>Faulty load valve.</i>	Replace the valve.
	<i>Faulty switch.</i>	Test switch
	<i>Loose pipe/hose connections.</i>	Check all pipe/hose connections.

OPTIONS

OPTIONS – Lubricator

(For units manufactured in North America)

SAFETY

WARNING: Ensure that the lubricator filler cap is re-tightened correctly after replenishing with oil.

WARNING: Do not replenish the lubricator oil, or service the lubricator without first making sure that the machine is stopped and the system has been completely relieved of all air pressure (Refer to *STOPPING THE UNIT* in the *OPERATING INSTRUCTIONS* section of this manual).

CAUTION: If the nylon tubes to the lubricator are disconnected then ensure that each tube is re-connected in its original location.

GENERAL INFORMATION

Oil capacity:
1 QT Option –0.95 Litre (1qt)
2 QT Option –1.9 Litre (2qts)

Oil specification:
Refer to the *Tool Manufacturer's Manual*.

OPERATING INSTRUCTIONS

COMMISSIONING

Check the lubricator oil level and fill as necessary.

PRIOR TO STARTING

Check the lubricator oil level and replenish as necessary.

MAINTENANCE

Check the lubricator oil level and replenish as necessary.

FAULT FINDING

FAULT	CAUSE	REMEDY
No oil flow.	<i>Incorrect connection.</i>	Reverse the nylon tube connections to the lubricator.

OPTIONS

OPTIONS – Dual pressure

SAFETY

WARNING: Any pneumatic equipment that is, or may be connected to the machine must be suitable for use with at least the higher, rated pressure.

OPERATING INSTRUCTIONS

COMMISSIONING

Check that switch and solenoid are functioning correctly.

Switch handle up: Lower pressure selected

Switch handle right: Higher pressure selected

STARTING AND USE

Select higher pressure setting with valve handle (handle to right) and start machine normally.

If lower pressure is required then turn handle to up position.

Toggle between high and low pressure as required.

OPTIONS – IQ SYSTEM

SAFETY

CAUTION: The compressor regulation system is adjusted to maintain regulated pressure at the separator tank. DO NOT adjust regulation to provide full regulation pressure at the service valve when the IQ System is enabled. This will result inC operation at excessive horsepower levels, causing overheating, reduced engine life, and reduced aircend life.

CAUTION: Excessively restricted filter elements may cause an increase in the amount of aerosol water and oil carryover, which could result in damage to downstream equipment. Normal service intervals should not be exceeded.

CAUTION: Blockage of the condensate will result in flooding of the vessels. If flooding occurs, excessive condensate may enter the air stream and could result in damage to downstream equipment.

CAUTION: Do not remove u-bolts from both filters at the same time. Removing both u-bolts will place excessive stress on the aftercooler.

NOTICE:

Do not operate at temperatures less than 2°C (35°F) unless equipped with low ambient IQ option.

OPERATING INSTRUCTIONS

Starting and use:

Select desired air type using diverter valve and start machine normally.

Using diverter valve, toggle between standard air and IQ air as required.

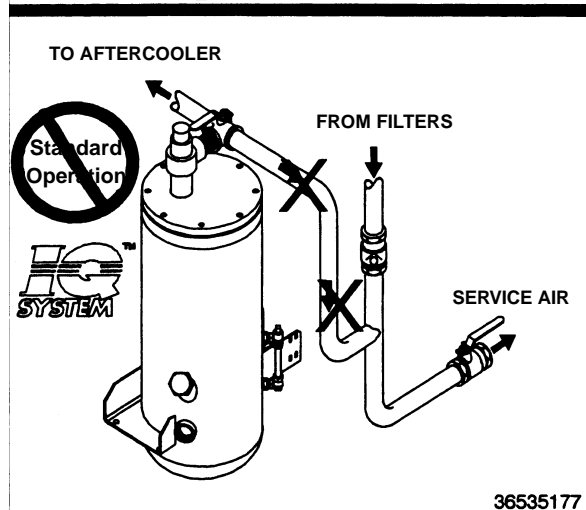
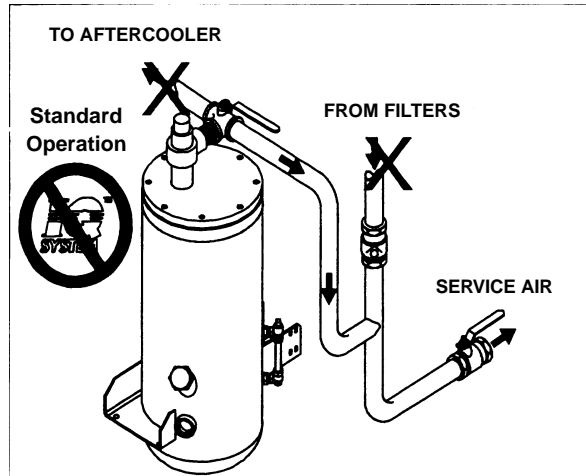

36535177

MAINTENANCE

Daily maintenance:

Verify, during full-load (maximum compressed air delivery) that the IQ system filter restriction indicators do not show excessive restriction.

Restriction indicators for primary and secondary filters are located on the filter heads. If so equipped, an automatic restriction indicator is located behind the filter mounting bracket and will shut down the compressor if restriction exceeds recommended values.

Weekly Maintenance:

- Verify that the piping from the water separator and filters to the exhaust system is not clogged.

Yearly Maintenance:

The normal maintenance interval on the primary and secondary IQ System filters is one year, or earlier if pressure drop becomes excessive.

Restriction indicators for the filters are mounted on the filter heads. If so equipped, an automatic restriction indicator located behind the filters will shut down the compressor if restriction exceeds recommended values.

Filter replacement.

- Remove all wires and hoses connected to drains on bottom of each filter housing. Inspect fittings and hoses for any blockage. Clean if necessary.
- Using a chain wrench or similar tool, loosen the housing. The housing should be removed by hand after loosening, taking care to prevent the housing from falling to the floor panel.
- Lower the housing to floor panel. Remove and replace the filter element, being careful not to damage outer wrap.
- Put a small amount of petroleum jelly or other non-synthetic grease on the element o-ring to aid installation into the filter head.
- Replace housing making sure not to overtighten.
- Repeat the above procedure on the remaining filter element.
- Reconnect all wires and hoses to drains on bottom of each filter housing.

PARTS ORDERING

GENERAL

This publication, which contains an illustrated parts breakdown, has been prepared as an aid in locating those parts which may be required in the maintenance of the unit. All of the compressor parts, listed in the parts breakdown, are manufactured with the same precision as the original equipment. For the greatest protection always insist on genuine Ingersoll-Rand Company parts for your compressor.

NOTICE

Ingersoll-Rand Company can bear no responsibility for injury or damages resulting directly from the use of non-approved repair parts.

Ingersoll-Rand Company service facilities and parts are available worldwide. There are Ingersoll-Rand Company Construction Equipment Group Sales Offices and authorized distributors located in the principal cities of the United States. In Canada our customers are serviced by the Canadian Ingersoll-Rand Company, Limited. There are also Ingersoll-Rand International autonomous companies and authorized distributors located in the principal cities throughout the free world.

Special order parts may not be included in this manual. Contact the Mocksville Parts Department with the unit serial number for assistance with these special parts.

DESCRIPTION

The illustrated parts breakdown illustrates and lists the various assemblies, subassemblies and detailed parts which make up this particular machine. This covers the standard models and the more popular options that are available.

A series of illustrations show each part distinctly and in location relative to the other parts in the assembly. The part number, the description of the part and the quantity of parts required are shown on each illustration or on adjacent page. The quantities specified are the number of parts used per one assembly and are not necessarily the total number of parts used in the machine. Where no quantity is specified the quantity is assumed to be one.

Each description of a part is based upon the "noun first" method, i.e., the identifying noun or item name is always the first part of the description. The noun name is generally followed by a single descriptive modifier. The descriptive modifier may be followed by words or abbreviations such as upper, lower, inner, outer, front, rear, RH, LH, etc. when they are essential.

In referring to the rear, the front or to either side of the unit, always consider the **drawbar end** of the unit as the **front**. Standing at the rear of the unit facing the drawbar (front) will determine the right and left sides.

FASTENERS

Both SAE/inch, ISO/metric hardware have been used in the design and assembly of these units. In the disassembly and reassembly of parts, extreme care must be taken to avoid damaging threads by the use of wrong fasteners. In order to clarify the proper usage and for exact replacement parts, all standard fasteners have been identified by part number, size and description. This will enable a customer to obtain fasteners locally rather than ordering from the factory. These parts are identified in tables that will be found at the rear of the parts illustrations. Any fastener that has not been identified by both part number and size is a specially engineered part that must be ordered by part number to obtain the exact replacement part.

MARKINGS AND DECALS

NOTICE

Do not paint over safety warnings or instructional decals. If safety warning decals become illegible, immediately order replacements from the factory.

Part numbers for original individual decals and their mounting locations are shown within Parts List Section. These are available as long as a particular model is in production.

Afterwards, service sets of exterior decals and current production safety warning decals are available. Contact the Product Support Group at Mocksville for your particular needs and availability.

HOW TO USE PARTS LIST

- a. Turn to Parts List.
- b. Locate the area or system of the compressor in which the desired part is used and find illustration page number.
- c. Locate the desired part on the illustration by visual identification and make note of part number and description.

HOW TO ORDER

The satisfactory ordering of parts by a purchaser is greatly dependent upon the proper use of all available information. By supplying your nearest sales office, autonomous company or authorized distributor, with complete information, you will enable them to fill your order correctly and to avoid any unnecessary delays.

In order that all avoidable errors may be eliminated, the following instructions are offered as a guide to the purchaser when ordering replacement parts:

- a. Always specify the model number of the unit as shown on the general data decal attached to the unit.
- b. Always specify the serial number of the unit. **THIS IS IMPORTANT.** The serial number of the unit will be found stamped on a plate attached to the unit. (The serial number on the unit is also permanently stamped in the metal of the frame side rail.)
- c. Always specify the number of the parts list publication.
- d. Always specify the quantity of parts required.

- e. Always specify the part number, as well as the description of the part, or parts, exactly as it is given on the parts list illustration.

In the event parts are being returned to your nearest sales office, autonomous company or authorized distributor, for inspection or repair, it is important to include the serial number of the unit from which the parts were removed.

TERMS AND CONDITIONS ON PARTS ORDERS

Acceptance: Acceptance of an offer is expressly limited to the exact terms contained herein. If purchaser's order form is used for acceptance of an offer, it is expressly understood and agreed that the terms and conditions of such order form shall not apply unless expressly agreed to by Ingersoll-Rand Company ("Company") in writing. No additional or contrary terms will be binding upon the Company unless expressly agreed to in writing.

Taxes: Any tax or other governmental charge now or hereafter levied upon the production, sale, use or shipment of material and equipment ordered or sold is not included in the Company's price and will be charged to and paid for by the Purchaser.

Shipping dates shall be extended for delays due to acts of God, acts of Purchaser, acts of Government, fires, floods, strikes, riot, war, embargo, transportation shortages, delay or default on the part of the Company's vendors, or any other cause beyond the Company's reasonable control.

Should Purchaser request special shipping instruction, such as exclusive use of shipping facilities, including air freight when common carrier has been quoted and before change order to purchase order can be received by the Company, the additional charges will be honored by the Purchaser.

Warranty: The Company warrants that parts manufactured by it will be as specified and will be free from defects in materials and workmanship. The Company's liability under this warranty shall be limited to the repair or replacement of any part which was defective at the time of shipment provided Purchaser notifies the Company of any such defect promptly upon discovery, but in no event later than three (3) months from the date of shipment of such part by the Company. The only exception to the previous statement is the extended warranty as it applies to the special airend exchange program.

Repairs and replacements shall be made by the Company F.O.B. point of shipment. The Company shall not be responsible for costs of transportation, removal or installation.

Warranties applicable to material and equipment supplied by the Company but wholly manufactured by others shall be limited to the warranties extended to the Company by the manufacturer which are able to be conveyed to the Purchaser.

Delivery: Shipping dates are approximate. The Company will use best efforts to ship by the dates specified; however, the Company shall not be liable for any delay or failure in the estimated delivery or shipment of material and equipment or for any damages suffered by reason thereof.

The company makes no other warranty or representation of any kind whatsoever, expressed or implied, except that of title, and all implied warranties, including any warranty of merchantability and fitness for a particular purpose, are hereby disclaimed.

Limitation of Liability:

The remedies of the Purchaser set forth herein are exclusive, and the total liability of the Company with respect to this order whether based on contract, warranty, negligence, indemnity, strict liability or otherwise, shall not exceed the purchase price of the part upon which such liability is based.

The Company shall in no event be liable to the Purchaser, any successors in interest or any beneficiary of this order for any consequential, incidental, indirect, special or punitive damages arising out of this order or any breach thereof, or any defect in, or failure of, or malfunction of the parts hereunder, whether based upon loss of use, lost profits or revenue, interest, lost goodwill, work stoppage, impairment of other goods, loss by reason of shutdown or non-operation, increased expenses of operation or claims of customers of Purchaser for service interruption whether or not such loss or damage is based on contract, warranty, negligence, indemnity, strict liability or otherwise.

AIREND EXCHANGE PROGRAM

Ingersoll-Rand offers an airend exchange program to benefit portable compressor users.

On the airend exchange program the exchange price is determined by the age and condition of the airend.

Your nearest sales office, autonomous company or authorized distributor must first contact the Parts Service Department at the factory at which your portable air compressor was manufactured for an airend exchange number. The airend must be tagged with this preassigned number and returned to the factory prepaid. The airend must be intact, with no excluded parts, otherwise the exchange agreement may be cancelled. The warranty on an exchange or factory rebuilt airend is 365 days.

Airends being returned to the factory in connection with a WARRANTY CLAIM must be processed through the Customer Service Department. If returned without a Warranty MRR (Material Return Request) Number, no warranty claim will be considered.

For information on how to order parts or information regarding your local distributor (Europe, Middle East, Africa) please contact:

Facility:

Portable Power Aftermarket ESA
Ingersoll-Rand European Sales Ltd
Swan Lane, Hindley Green
Wigan WN2 4 EZ
United Kingdom

Telephone: +44 (0) 1942 257 171

Emergency order telephone # +44 (0) 777 617 0921

Fax: +44 (0) 1942 523 417

Office hours: Monday – Friday 8:00 a.m. to 4:30 p.m. (GMT)