

XAS 950 CD8 T4F

Portable compressor



Standard Scope of Supply

The Atlas Copco **XAS 950 CD8 T4F** is a single-stage, oil-injected, rotary screw type air compressor, powered by a liquid-cooled, six-cylinder turbocharged diesel engine.

The unit consists of an air end, diesel engine with exhaust treatment, cooling circuit, air/oil separation and control systems - all enclosed within a sound dampened steel enclosure.

A range of undercarriage formats, factory and locally installed options are available.

Special attention has been given to the overall product quality, user friendliness, ease of serviceability, and economical operation to ensure best in class cost of ownership.

Pressure and Flow

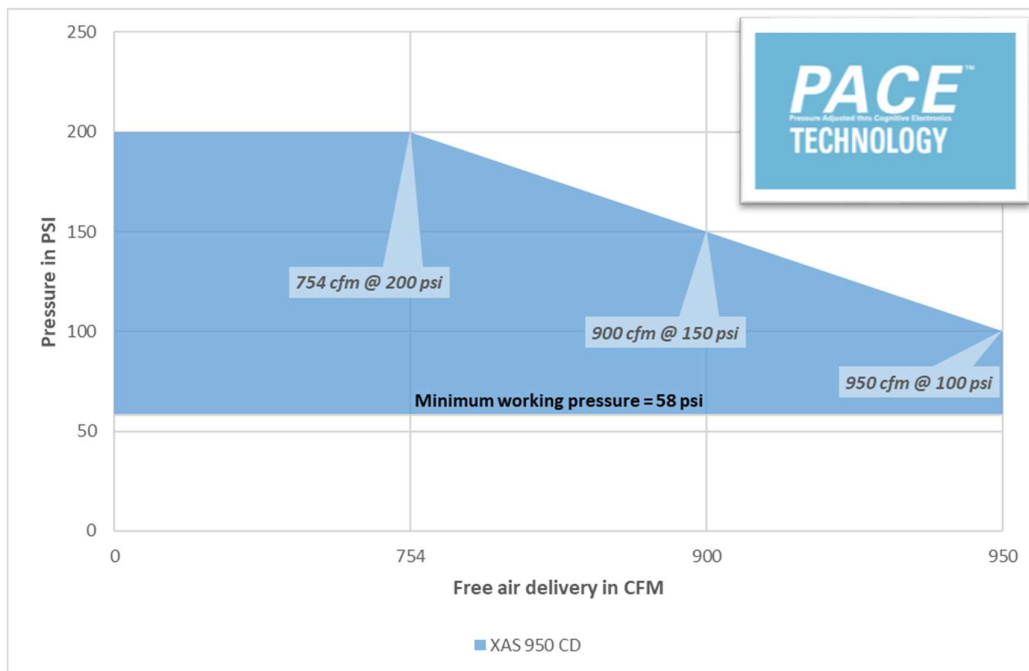

Available Models

XAS 950 CD8 T4F

Single stage – 100 to 200 psi – Caterpillar engine

Features

- Caterpillar T4F engine
- Atlas Copco Controller XC2003 PACE
PACE = Pressure Adjusted through Cognitive Electronics
- 110% Spillage Free Containment Frame
- Low Fuel Shutdown
- Heavy Duty Single Axle Trailer w/ 17.5 tires
- FuelXpert™
- PFF (Portable Full Feature) air treatment:
Aftercooler, Water Separator and DD&PD Filters
- Cold Weather Package

Benefits

- Meets all current T4F emission regulations.
- Integrated exhaust aftertreatment makes T4F integration easy
- Extended warranty available through Caterpillar dealer
- Improved altitude performance with turbo-charged engine
- Proven controller for easy operation and diagnostics of the compressor and engine.
- Allows operator to view compressor parameters including: Pressure settings, reading engine codes, two programmable service timers, all temperatures and pressures of compressor, fuel levels and consumptions, and load/unload compressor.
- Protects environment, avoids costly clean up liability
- Reduces downtime on site when operator runs out of fuel as there is no longer a need to "re-prime" the fuel system
- Well balanced for safer towing or moving around site
High ground clearance for rough site and road conditions
- Reduces fuel consumption up to -10% at 75% load
- Lowers operational costs, increases project profitability
- Provides cool, dry, clean air for applications where instrument quality air is required.
- Features required for reliable cold weather operation.
Including; synthetic compressor oil, coolant heater and ether start

Technical Data

Compressor

XAS 950 CD8 T4F

Normal effective working pressure	psig	200	150	100
Actual free air delivery ¹ (FAD) at pre-set pressure setting	cfm	754	900	950
Maximum unloading pressure	psig	232	232	232
Minimum working pressure	psig	58	58	58
Max. sound pressure level @ 23' (7m) at normal working speed & pressure ²	dB(a)	72	72	72
Compression Stages		1	1	1
Air Receiver Capacity	US Gal (L)	24 (91)	24 (91)	24 (91)
Compressor oil capacity	US Gal (L)	9 (34)	9 (34)	9 (34)
Approximate air outlet temperature (without use of PFF)	°F (°C)	200 (93)	200 (93)	200 (93)
Air Compressor outlets	Qty & Size	2 x ¾" & 2 x 2"	2 x ¾" & 2 x 2"	2 x ¾" & 2 x 2"
Max. ambient temperature (at sea level) ³	°F (°C)	121 (49.4)	121 (49.4)	121 (49.4)
Maximum altitude	Ft (m)	10000 (3048)	10000 (3048)	10000 (3048)
Minimum starting temperature	°F (°C)	-13 (-25)	-13 (-25)	-13 (-25)

Engine

	Caterpillar	C 7.1	C 7.1	C 7.1
Emissions Regulation	US EPA Tier	T4F	T4F	T4F
Output at rated speed (2400 rpm)	HP	302	302	302
Number of cylinders		6	6	6
Aspiration		Turbocharged	Turbocharged	Turbocharged
Displacement	cu in (L)	428 (7.1)	428 (7.1)	428 (7.1)
Engine speed (Unloaded)	rpm	1300	1300	1300
Engine speed (Maximum loaded)	rpm	2200	2200	2200
Engine oil capacity	US Gal (L)	4.2 (16)	4.2 (16)	4.2 (16)
Engine oil required		Low Ash Oil per API CJ-4, ACEA C9		
Engine coolant capacity	US Gal (L)	12.9 (49)	12.9 (49)	12.9 (49)
Fuel tank capacity	US Gal (L)	90 (340)	90 (340)	90 (340)
Fuel consumption at 0% load	Gal/Hr (L/Hr)	2.37 (9)	2.37 (9)	2.37 (9)
Fuel consumption at 100% load (normal effective working pressure)	Gal/Hr (L/Hr)	12.08 (46)	13.21 (50)	12.42 (47)
DEF tank capacity	US Gal (L)	8.45 (32)	8.45 (32)	8.45 (32)
DEF consumption at 100% load	Gal/Hr (L/Hr)	0.42 (1.59)	0.46 (1.74)	0.43 (1.63)
Battery Capacity (Cold Cranking Amps ⁴)	A	2 x 1100	2 x 1100	2 x 1100

¹ According to ISO 1217 ed.3 1996 annex D

² Measured in accordance with ISO 2151 under free field conditions @ 7m distance

³ Consult Atlas Copco for proper de-rating instructions for operation beyond ambient limitations

⁴ According to DIN 72311

Dimensions

Trailer mounted

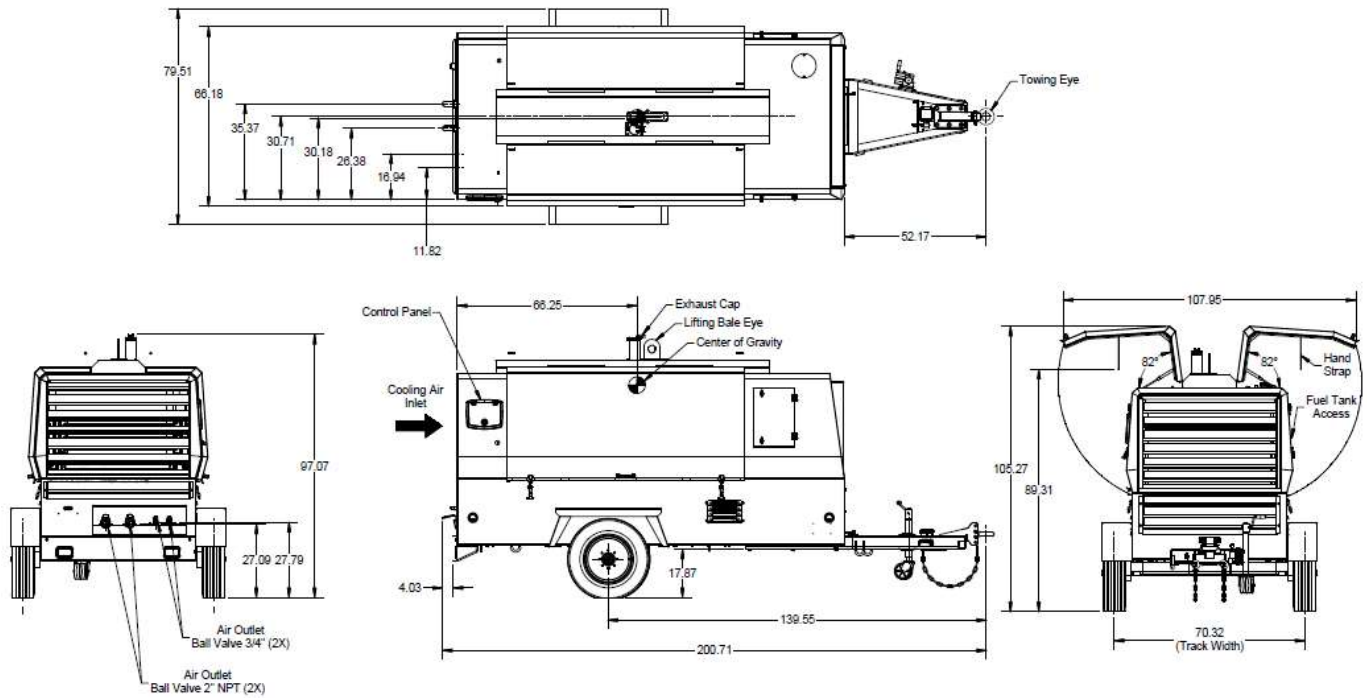

Support mounted

TBD

Weight (Wet - Ready-to-operate)

XAS 950 CD8 T4F

Trailer mounted	lb (Kg)	8200 (3719)
Support mounted (approx.)	lb (Kg)	TBD

Dimensions

XAS 950 CD8 T4F

Trailer mounted	Inches (mm)	L x W x H	201 x 80 x 97 (5105 x 2032 x 2425)
Support mounted	Inches (mm)	L x W x H	149 x 66.5 x 78 (3784 x 1689 x 1981)

Principle Data

Compressor Element

The quality of a compressor can be measured through the reliability, efficiency and durability of the compressor element used. Through decades of expertise in the design of compressor elements, Atlas Copco remains a world leader in designing the most efficient and reliable compressors on the market. With air-end efficiency, maintenance intervals are extended and fuel consumption is reduced.

The XAS 950 CD8 T4F compressors utilizes Atlas Copco's C142 element and is driven from the diesel engine through a gear box with a fibre disc coupler.

The compressor system comes with Atlas Copco PAR Oil compressor oil. The oil cooler comes equipped with a standard thermostatic by-pass valve for superior cold weather lubrication.

Air/Oil Separator

Air and oil separation is achieved through a centrifugal oil separator combined with a filter element. Separators come standard with an ASME, CRN and AS1210 (triple certified) certified tank and are stamped accordingly.

Designed for a higher maximum working pressure, the separator is equipped with a sealed high pressure safety relief valve, minimum pressure valve, automatic blow-down valve, and pressure regulator.

Air/Oil Separator Tank:

Volume	24 US Gal / 91 L
Certifications	ASME / CRN
MAWP	305 psi @ 266°F

Cooling System

The cooling system consists of integrated side-by-side aluminum oil cooler with axial fan to ensure optimum cooling. The cooling system is suitably designed for continuous operation in ambient conditions up to 125°F, with canopy door closed for the XAS 950 CD8 TF4.

Compressor Regulating System

The compressor regulating system consists of an air filter, air receiver/oil separator, compressor element, unloader assembly with unloader valve, blow down valve and loading valve.

Economic power consumption is assured by the fully automatic 100% step-less speed regulator that adapts engine speed to air demand.

PACE (Pressure Adjusted through Cognitive Electronics) electronic pressure regulation system provides greater operator flexibility for pressure setting. Two (2) operational set-points (min/max) in 2 psig increments can be pre-programmed for greater flexibility when multiple pressures are needed on application.

Discharge Outlets

Compressed air is available from 2 x 3/4" outlet valves and 2 x 2" NPT valves. 1 x 2" NPT valve dedicated to quality filtered air through the PFF system.

Engine

Caterpillar C 7.1

Caterpillar C 7.1 turbo charged six-cylinder, liquid-cooled Tier 4 Final compliant diesel engine provides ample power to operate the compressor continuously at full-load.

Meets all US EPA and Environment Canada exhaust legislations with Final Tier 4 compliance.

The US EPA engine family is "KPKXL07.0BN1" and rated at 302 hp at 2200 rpm, in accordance to SAE Standard

Engine starting capacity at -13°F (-25°C).

The 90 Gal (340 L) fuel tank enables operation for 7.25 hours at full load and comes standard with a low fuel shutdown at 5%.

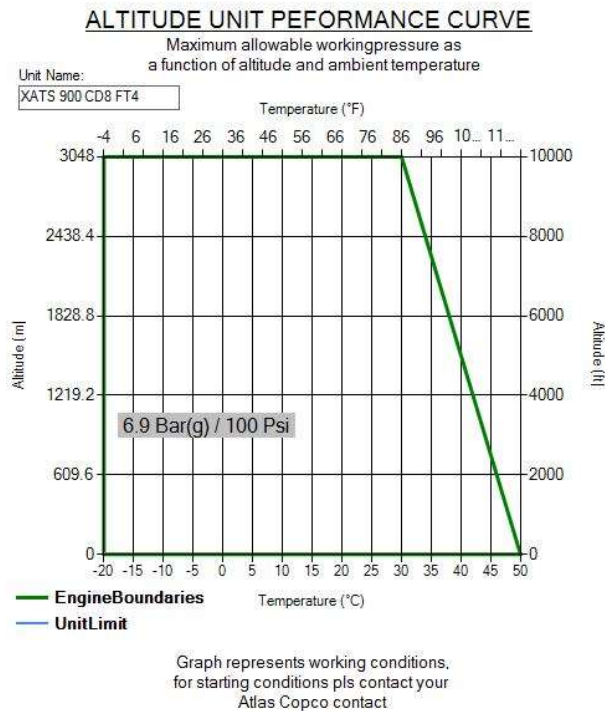

Emissions Treatment

Caterpillar C 7.1 T4F engine after treatment consists of a Diesel Oxidation Catalyst (DOC), passive Diesel particulate Filter (DPF) and Selective Catalytic Reduction (SCR). The SCR utilizes the temperature of the exhaust to passively regenerate during normal use.

Electrical System

The **XAS 950 CD8 T4F** range is equipped with a 24 Volt negative ground electrical starting system.

Instrumentation

The instrument control panel is located on the back, curbside of the compressor canopy with easy access.

Standard instrument package includes fully diagnostic ECU controller with large 3.5" display. The intuitive Atlas Copco XC2003 controller is easy to operate with all functions conveniently at your fingertips. The controller also manages the engine ECU operating system, and a number of safety warnings, shut downs on various parameters (listed below) and full digital pressure control with PACE.

PACE functionality can be viewed on YouTube at <https://www.youtube.com/watch?v=1rj-vtATCoI>

XC2003 Controller Functionality:

- Displayed while running
 - Hours
 - Fuel level
 - RPM
 - Outlet pressure
- Operational Buttons
 - Start and stop of the unit
 - View measurements, settings and alarms
 - Multi position cursor to navigate menus
 - PACE digital pressure control
- Compressor measurements displayed
 - Running hours
 - Fuel level
 - Clock
 - Battery voltage
 - Running hours
 - Regulating pressure
 - Emergency stop count
 - Average fuel consumption
 - Minor and major service counters in hours and days
- Engine measurements displayed
 - Fuel consumption per hour tally
 - Engine coolant temperature
 - Engine oil pressure
 - Engine RPM

- Warnings and Shutdowns
 - High temperature engine coolant
 - High temperature compressor oil
 - Engine oil pressure
 - Low fuel level
- Settings
 - Reset service timers
 - Diagnostics for engine ECU
 - Language settings
 - Unit of measure changes
 - Electronic pressure adjustment
- Alarms
 - View current & historical alarms present
 - History of last 20 alarms and events with time and date stamps
 - DM1 & DM2: View current engine codes (SPN/FMI)



Bodywork

The compressor comes standard with metal canopy that has a 2 layer protective coating (Primer base and Powder Coated top layer) providing excellent corrosion protection. The canopy is sound attenuated to meet the most current legal noise requirements. Large service doors offer easy service access to all components from all sides of the machine.

Undercarriage & Frame

The **XAS 950 CD8 T4F** range compressor is available with two undercarriage alternatives, providing utmost flexibility in installation or towing requirements.

- Single axle trailer setup with:
 - DOT approved light package
 - Adjustable height pintle hitch (3" lunette)
 - 8,000 lbs torsional axle {GAWR – 7415 lb (3363 kg)}
 - 17.5" Rims w/ 215/75R17,5 Tires
 - Electric trailer brakes as standard (with 7 pin flat blade connector), Hydraulic surge-type brakes optional
 - 1500 lbs jack leg stand, with wheel
- Support mounted version, on steel frame, less undercarriage is available

The **XAS 950 CD8 T4F** range has as standard a spillage free containment base frame, to avoid potential fluid leaks to environment.

Factory Options Available

- Fixed Hydraulic surge-type Brakes undercarriage (Electric Brakes are standard)
- Support Mount
- Inlet shut-down
- Spark arrester
- External fuel connection

Manufacturing & Environmental Standards

The **XAS 950 CD8 T4F** range are manufactured following stringent ISO 9001 regulations, and a fully implemented Environmental Management System fulfilling ISO 14001 requirements.

Attention has been given to ensure minimum negative impact to the environment.

The **XAS 950 CD8 T4F** range meets all current EPA and Environment Canada exhaust and noise emission directives.

Supplied Documentation

The unit is delivered with documentation regarding:

- Hard copies of the Atlas Copco Operators Safety and Instruction Manual, Caterpillar Engine Operators Manual, as well as electronic copies, available upon request.
- Warranty Registration card for Caterpillar Engine and Atlas Copco Compressor (Units must be registered upon receipt).
- Test certificate for air delivery pressure and capacity, acc. ISO 1217 (Upon request only).
- Certificate for air/oil separator vessel and safety valve approval, ASME (Upon request only).

Warranty Coverage

Caterpillar Engine: Caterpillar Diesel engines are warranted to be free from defects with regard to materials and workmanship for the period of twelve (12) months from the date of initial startup without limitation in running hours or for the period of thirty six (36) months from the date of initial startup prior to the accumulation of 4000 running hours.

Atlas Copco Compressor: Warrantied to be free from defects with regard to material and workmanship for the period of eighteen (18) months from date of shipment from the factory, or twelve (12) months from date of initial start-up, whichever occurs first, without limitation of running hours.

Air compressor element assemblies used in Atlas Copco portable air compressors, is warranted to be free from defects with regard to materials and workmanship for the period of thirty (30) months from date of shipment from the factory, or twenty four (24) months from date of initial start up, whichever occurs first, without limitation of running hours. Atlas Copco service kits including parts and oils (PAR Oil's) must be used to maintain warranty. Failure to register warranty upon initial start-up may cause warranty claim delays or rejection of claims.

PRODUCT: Portable Compressors	EXTENDED WARRANTY PERIOD*: 24 months from date of end of initial standard warranty term. For the compressor's air system **, the warranty period is an additional 96 months from the end of the 24 month extended warranty term. For the engine, see Footnote 1 below.
<p>* Requirements for Extended Warranty;</p> <ul style="list-style-type: none"> · Service maintenance must be completed according to published intervals while utilizing genuine Atlas Copco/Chicago Pneumatic/American Pneumatic Tool parts and lubricants. Record of such maintenance must be entered onto Machines Online for the specific serial number and include all required information including date service performed, service interval performed, and part numbers used. · Oil sample (engine or compressor) to be taken at any time of failure and available upon request <ul style="list-style-type: none"> · Oil sample kit part number 9753300442 available for purchase · Unit must be available for onsite inspection by a representative of Power Technique North America if required · Unit must be available for transport to a Power Technique North America service center location if required · Failed components must be retained and available for return and inspection if required 	
<p>** Air end system component exclusions: Electrical components (i.e. Sensors, wiring), Perishable items (i.e. Rubber, plastics), Wear and air regulation items (i.e. Check valves, couplings)</p>	
<p>Note: End users are authorized to complete the required preventative maintenance utilizing genuine parts and lubricants purchased from an authorized dealer. Service maintenance recorded into Machines Online are to be completed by the authorized dealer where products purchased or another authorized dealer after providing proof of purchase for genuine parts and fluids utilized..</p>	
<p>Note: Equipment/machinery/components/Accessories/parts/items sold by SELLER but not manufactured by SELLER or an affiliate (including but not limited to a Product's engine, alternator, tires, battery, carrier, electrical equipment, and hydraulic transmission, if applicable) are not warranted by SELLER and shall carry whatever warranty (if any) which the manufacturer has conveyed to SELLER to the extent it can be passed on to the purchaser.</p>	