



**GLOBAL SERIES  
DIESEL POWERED TWO STAGE  
SCREW AIR COMPRESSORS**

**PG 1200S-Combo 350 (Domestic & International) /**

**PG 1200S - 330 /**

**PG 1100S - 300**

**SKID MOUNTED**

**OPERATION AND MAINTENANCE MANUAL  
PARTS MANUAL**

©

**ELGI EQUIPMENTS LIMITED**

Coimbatore, TN - 641 005

Part / Document No. 03 94 000 24

**Print Status**

R00 - June - 2013

R01 - 1st Revision April - 2014

R02 - 2nd Revision October - 2014

R03 - 3rd Revision November - 2014

R04 - 4th Revision December - 2014

R05 - 5th Revision August - 2015

Contact Info :

**Elgi Equipments Limited**

**Trichy Road, Singanallur**

Coimbatore, TN - 641 005, India

Tel : 91 - 422 2589555

Fax : 91 - 422 2591384 (Domestic Business)

Fax : 91 - 422 2589401 (International Business)

E-mail : enquiry@elgi.com, ccs@elgi.com, www.elgi.com

Domestic Toll free No. : 1800 425 3544

**Customer Care No. :0091 422 2589242, 243, 244 , 245**

## Machine Identification and Sale Record

Owner's Name : \_\_\_\_\_

Address : \_\_\_\_\_

Model : \_\_\_\_\_

FAB No. : \_\_\_\_\_

Year of Manufacture : \_\_\_\_\_

Engine : \_\_\_\_\_ hp

Capacity : \_\_\_\_\_ m<sup>3</sup>/ min

Rated Pressure : \_\_\_\_\_ bar g

Date of Delivery : \_\_\_\_\_

Date of Commissioning : \_\_\_\_\_

Dealer's Name/Code : \_\_\_\_\_

Dealer's Signature and Stamp

**Note: The warranty on this compressor is valid only if all the details above are filled in and the dealer stamps and signs this page**

**Note: To avail warranty benefits, please fill above information and send it to customer care mail ID for registration purpose.  
Email: [ccs@elgi.com](mailto:ccs@elgi.com)**

## Owner Possession Information

Warranty Book Serial No. : \_\_\_\_\_  
Customer Code : \_\_\_\_\_  
Customer Name : \_\_\_\_\_  
Customer Address : \_\_\_\_\_

### Contact Data

Phone : \_\_\_\_\_  
Mobile GSM : \_\_\_\_\_  
Mobile CDMA : \_\_\_\_\_  
Fax : \_\_\_\_\_  
E-mail : \_\_\_\_\_  
Compressor Type : \_\_\_\_\_  
Compressor Model : \_\_\_\_\_  
Fabrication No. : \_\_\_\_\_  
Invoice No. : \_\_\_\_\_  
Date of Delivery : \_\_\_\_\_  
Place of Purchase : \_\_\_\_\_  
Airend Type : \_\_\_\_\_  
Airend Serial No. : \_\_\_\_\_  
Engine Model : \_\_\_\_\_  
Engine Serial No. : \_\_\_\_\_

## Message from the Managing Director

It gives me great pleasure to welcome you to the family of users of the Global Series Diesel Powered Screw Air compressors from Elgi, among the most sophisticated rotary screw air compressors available in the world today.

Elgi has designed your Global Series Compressor to be reliable, safe, easy to maintain and friendly to use in meeting your compressed air requirements. This user manual will enable you to use the Global Series Compressor optimally. Please familiarize yourself with all the information it contains.

I look forward to your continued satisfaction as a Global user. Elgi is honoured to be your choice for all your compressed air needs.

Yours sincerely



(signed)

## About ELGI

Elgi, established in 1960, designs and manufactures a wide range of compressors. The company has gained its reputation for design and manufacture of screw compressors through strategic partnerships and continuous research and development.

Screw compressor elements are manufactured in-house using state-of-the-art machining centres for rotor grinding and machining castings of various sizes. Elgi's own eta-V profile rotors ensure energy-efficient compressed air supply for all demanding applications. Elgi is one of the few companies capable of manufacturing wide range of airends and compressor packages in the world. Elgi's patent portfolio is a testament to the company's continuous research and innovation capability.

Elgi has modern manufacturing facilities in equipped with advanced high precision grinding machines, turning centres and CNC horizontal and vertical machining centres. Screw airends are manufactured with the latest rotor grinding technology, coupled with measurement technology to maintain precise manufacturing tolerances. Elgi's manufacturing plants are both ISO and EOHS certified. Elgi serves the world marketplace. Over two million compressors are powering business in 63 countries worldwide. The company offers a strong sales and service network with a well-knit distribution network of dealers and distributors worldwide. Elgi has its own manufacturing facilities in China, France, India and Italy. Additionally, Elgi has warehouse operations to stock units and parts in Australia, Brazil, UAE and USA.

## Introduction

Elgi Equipments Limited is a leading Indian manufacturer of Rotary Screw Air Compressors. Elgi Rotary Screw Air Compressors are widely used in India and other parts of the world. The equipment is known for their reliability, maintenance, friendliness and safety. Every Screw Type Air Compressor is designed keeping in mind three key quality considerations viz.

1. Energy Efficiency
2. Air Quality
3. Maintenance

We are confident that the equipment you have purchased will give you satisfactory service for its life.

We thank you for giving us an opportunity to serve you with our Compressor. Please check and ensure Operation and Maintenance Manual, Parts Manual and Engine Manual are received along with the compressor. If not, contact your local Dealer / Elgi equipments Ltd.

This Operation and Maintenance Manual has been specially designed keeping you in mind, so that you can get the most out of Elgi Compressor. Before you start using your compressor, do go through this manual thoroughly. It contains vital information on operations and useful tips that will keep your compressor running as good as new, year after year.

All information, illustrations and specifications in this manual are based on the latest product development available at the time of supply. We reserve the right to make changes in the product at any time without notice. We assure you of the best service in maintaining uptime of the compressor through prompt service and supply of spare parts as per your requirements.

This manual has been prepared with utmost care to help the user to understand various systems involved in the compressor thoroughly through detailed descriptions, working conditions and illustrations. This manual must be made available to the compressor operating personnel at all times.

Please read the instructions very carefully, right to the end, as the operating life and reliability of the compressor depends to a large extent on correct operation and maintenance.

## General Information

Your Global Series Compressor belongs to a family of rotary screw compressors from Elgi. Overall, the features of your Global Series Compressor translate to convenience for you. The compressor has only two moving parts—the rotors—which do not touch each other but are separated by a thin film of oil, so that there is no wear. This also means that the reliability of the compressor is unsurpassed.

The screw compressor technology ensures that there is no reduction in output capacity even after many years of operation. It involves a continuous flow of air through helical cavities in the screw, and so the compressed air delivery is pulsation free. The design of the Global Series compressor gives you a compact and self-contained compressor. Because it has no reciprocating parts, it runs quietly and free of vibrations. The discharge temperature of the coolant oil is low, less than 90°C, and therefore carbonized oil is not formed in the compressor.

Please read the instructions in this manual carefully and follow them at all times. The operating life and reliability of the compressor depend to a large extent on correct operation and maintenance.

When calling your Elgi branch office, dealer or service centre regarding your compressor, keep at hand the details present on the name plate of the compressor and entered in the inside front cover of this manual.

When ordering spare parts, refer to the list provided in this manual and identify the part number. Specify the part number and quantity in addition to the name plate details.

## **ELGI's Customer Care System (CCS)**

Elgi provides high-quality customer care and after-sales support through the CCS, a computerized system developed in-house. The CCS aims to minimize the time taken to resolve complaints.

### **Service Requests/Complaints**

At the heart of the CCS is the toll-free telephone number for domestic 1800-425-3544 at the centralized customer care centre at Coimbatore. Customers can register their service requirements or complaints with coordinators here.

A unique tracking number is generated for each call logged by the CCS. The customer is sent an automatic e-mail acknowledgement with the tracking number and details of the call for reference.

A service engineer is assigned to the call, and the date and time of the engineer's visit are communicated to the customer by e-mail. Every requirement or complaint must be resolved and closed in the CCS within a specified time limit, failing which the call is brought automatically to the notice of the manager higher in the hierarchy, up to the level of the Managing Director. Thus the CCS ensures that not only are customer complaints logged, they are also attended on time every time.

### **Enquiries**

A number of calls received by the CCS relate to customers' queries regarding products and spare parts. The details are noted, and basic information on product specifications and usage are provided. The caller is informed whom to contact for further discussions. The enquiry is passed on to a salesperson at the Head Office or the appropriate branch for follow-up.

### **The CCS Database**

The CCS also creates a database of customers, adding every new customer calling and thereby building a large pool of installation details. These details are used to provide value-added services to improve customer satisfaction with Elgi products.

### **CCS-Working Hours**

Customers can now use the CCS from 08:30 to 21:30 IST five days a week (Monday to Friday). Elgi has received suggestions that the service be extended to Sundays.

### **Multi-lingual Capability**

The coordinators at the CCS are multi-lingual. They can handle calls in all the major regional languages of India.

### **Coverage**

The toll-free number of the CCS is accessible in domestic from the following areas:

**Southern Region:** Tamilnadu, Karnataka, Kerala, Pondicherry, Andhra Pradesh, Andaman & Nicobar Islands

**Western Region:** Maharashtra, Gujarat, Madhya Pradesh, Goa, Lakshadweep islands

**Eastern Region:** Orissa, Chattisgarh, Jharkhand, West Bengal, Bihar and the North-Eastern states

**Northern Region:** Rajasthan, Uttar Pradesh, Delhi, Haryana, Punjab, Uttaranchal, Himachal and Jammu & Kashmir.

### **Other Contact Numbers for Domestic Customers**

The CCS can also be availed through the following numbers:

Telephone: 009 - 4222589206  
                  - 4222589241  
                  - 4222589242  
                  - 4222589243  
                  - 4222589244  
                  - 4222589245  
                  - 4222589325  
                  - 4223254230

Fax: 0422-2573697- Domestic business  
      0422-2589401 - International business

### **For International Customers**

**Please send the following details through mail, enable us to take immediate action**

1. Name of the Customer
2. Compressor Model
3. Fab Number
4. Contact Person Name
5. Phone Number
6. Nature of Complaint
7. Hour Meter Reading

**You may use the CCS by sending e-mail to: [ccs@elgi.com](mailto:ccs@elgi.com)**

## Commissioning Process

### Customer Satisfaction Survey

If you have used the CCS, you may be contacted and your feedback sought on the after-sales support received by you. Your response helps Elgi to improve this service.

Before the new Global Series compressor is operated for the first time, it needs to be installed at your site according to Elgi's specifications. Elgi's commissioning engineer carries out a series of checks on the machine and the systems to which it is connected to ensure that it is in a condition to function safely and as desired. The engineer will then describe to the operator of your compressor how the equipment is to be operated and maintained. This procedure is referred to as the commissioning process.

The commissioning of your compressor ensures that it is installed safely: the general operating conditions of the equipment such as the cleanliness of the atmosphere, temperature and ventilation are checked. Technical details relating to your system such as particulars of your electrical installation are noted. The operator of your compressor is familiarized with all aspects of both its normal running and dealing with unusual situations. The commissioning process provides to Elgi data that will help understand your requirements better.

Please make preparations for commissioning your Global Series compressor according to the instructions provided in the Installation section of this manual. Ensure that the location chosen meets the requirements of accessibility, ventilation and safety.

Upon completion of the commissioning process, the commissioning engineer will fill in a document known as the commissioning report. Please verify the information filled in and attest the certificate of completion of commissioning. The Elgi commissioning engineer will also sign the report. Kindly hand over the commissioning report to the commissioning engineer. Please fill in also the warranty card that comes along with the compressor and hand it over to the engineer. The engineer will send the report and the card to Elgi's Service Department — Compressor Division, Head Office.

## Using this operation and Maintenance Manual

This operation and maintenance manual has been specially designed keeping you in mind so that you can get the most out of your Elgi Global Series Compressor. Before you start using your compressor, do go through this manual thoroughly. It contains vital information on operation as well as useful tips that will help you keep your compressor running as good as new year after year.

The manual has been prepared with utmost care to help you understand the various systems of the compressor thoroughly through descriptions, information and illustrations.

All information, illustrations and specifications in this manual are based on the latest product information at the time of preparation of the manual. We reserve the right to make changes in the product at any time without notice. The manual must be available at all times to the personnel operating the compressor.

**The manual must be available at all times to the personnel operating the compressor.**

## Definitions and Symbols

### NOTE:

A **Note** clarifies procedures or conditions which may otherwise be misinterpreted or overlooked. A **Note** may also be used to clarify apparently contradictory or confusing situations.









### CAUTION:

A **Caution** is provided to draw attention to a procedure which, if not carried out done correctly, can lead to equipment damage.

### WARNING:

A **Warning** calls attention to dangerous or hazardous conditions inherent to the operation, cleaning and maintenance of the equipment which may result in personal injury or death of the operator or other persons.

### SYMBOLS:

	Never operate the machine without protective equipment		Never breathe in compressed air
	Never operate the unit with open doors or loose		<b>Warning:</b> Hot surface
	Danger of Electric Shock		<b>Warning:</b> Change the oil filter cartridge after approximately
	Lifting		<b>Warning:</b> Pressurized part or system
	<b>Warning:</b> Check the connecting terminals and retighten if required		



## List of Contents

<b>Section 1 USER INFORMATION</b>	<b>Page No.</b>
General	7.0
Warranty Information	7.0
Handling Compressor	7.5
Compressor Location	7.6
<b>Section 2 SAFETY</b>	<b>8.0</b>
<b>Section 3 DO'S AND DON'TS</b>	<b>9.0</b>
<b>Section 4 SALIENT FEATURES &amp; SPECIFICATIONS</b>	<b>10.0</b>
Salient Features	10.0
Technical Specifications	10.4
<b>Section 5 INSTALLATION</b>	<b>11.0</b>
General	11.0
Installation Requirements	11.0
Installation Guidelines for Skid Unit When Mounting on a Truck	11.1
Connection of the Compressor Air Supply	11.2
Electrical Connection	11.3
Diesel Tank Mounting Position with Respect to Engine Pump Arrangement	11.3
Pre-shipment Procedure for Units Shipping to Customers	11.3
<b>Section 6 COMMISSIONING</b>	
Points to Be Observed Before Initial Start	12.0
Points to Be Observed Before Starting	12.0
Preservation Procedure for Whole Package	12.2
General recommendations for Product Preservation -up to 6 months - Airend	12.2

## List of Contents

General recommendations for Product Preservation -up to 6 months - Engine	12.3
General recommendations for Product Preservation -up to 6 months - General	12.5
Pre-requisites for Commissioning	12.8
Checklist for Engine Preparation Before Commissioning	12.9
Checklist for Engine Running Performance	12.10
Compressor Re-Commissioning Checklist	12.11
Compressor Daily Maintenance Checklist	12.13
Compressor Routine Maintenance Checklist	12.14
Starting Procedure	12.15
<b>Section 7 WORKING PRINCIPLE</b>	<b>13.0</b>
<b>Section 8 SYSTEM OPERATION</b>	<b>14.0</b>
<b>Section 9 FUNCTIONS OF VARIOUS SYSTEMS</b>	<b>15.0</b>
Air Inlet System	15.0
Discharge System	15.2
Cooling System	15.4
Lubrication System	15.6
Two Stage Control System	15.8
Base System	15.15
Canopy System	15.16
Engine System	15.17
Lubrication Oil	15.18
<b>Section 10 SAFETY SYSTEM AND INTERLOCKING DEVICES</b>	<b>16.0</b>
Safety Devices	16.0
Interlocking Devices	16.3

## List of Contents

<b>Section 11 ELECTRICAL SYSTEM AND</b>	
<b>CONTROL ELEMENTS</b>	<b>17.0</b>
System Components and Description	17.2
Instrument Panel	17.3
Purpose of Controls	17.4
<b>Section 12 MAINTENANCE</b>	<b>18.0</b>
General	18.0
Daily Operation	18.0
Maintenance Checklist-After 500 Hours of Running	18.1
Maintenance Checklist-After 1500 Hours of Running	18.2
Maintenance Checklist-After 3000 Hours of Running	18.2
Maintenance Checklist-After 5000 Hours of Running	18.3
Components Maintenance and Replacement Procedure	18.4
Oil Filter	18.5
Separator Element	18.9
Air Inlet Filter Cleaning Procedure	18.11
Drive Coupling Dismantling	18.13
Assembling Procedure	18.14
Control System Adjustment	18.15
Operating Adjustment	18.15
Butterfly Valve Adjustment	18.15
Pressure Regulator Valve Adjustment	18.16
Idle Speed Adjustment	18.17
Minimum Pressure Valve	18.19
Oil Stop Valve	18.21

## List of Contents

Blow Down Valve	18.23
Discharge Check Valve	18.25
Pressure Regulator valve	18.27
Single Acting Actuator	18.29
Airend Maintenance	18.30
Oil Cooler and Radiator Maintenance	18.30
Battery Maintenance	18.30
Flushing the Compressor	18.32
<b>Section 13 TROUBLE SHOOTING</b>	<b>19.0</b>
Conversion Tables	20.0
Torque Values	21.0
Disclaimers	22.0
Business Reply Card	23.0
Feedback Form	24.0
<b>CHAPTER-II</b>	
<b>PARTS MANUAL</b>	
Air Inlet System	25.0
Discharge System	25.4
Cooling System	25.8
Lubrication System	25.12
Engine System	25.16
Control System	25.20
Canopy System	25.26
Base System	25.28
Instrumentation System Location	25.30
Airend Package	25.34
Recommended Spares	26.0
Dewpoint Temperature air	27.0
Notes	28.0

## User Information

### General

**ENSURE THAT THE COMPRESSOR IS LIFTED USING THE LIFTING EYE PROVIDED ON THE LIFTING BAIL ONLY.**

Ensure that this operation manual is made available at all times to the personnel operating the compressor.

Please read the instructions carefully and strictly adhere to them as the operating life and the reliability of the compressor depend to a large extent on correct operation and maintenance.

When communicating with an Elgi dealer/service centre/branch office regarding your compressor, ensure that all the details on the name plate (format shown below) are given. The name plate is fitted on the front of the compressor base frame. For ordering spare parts, refer to the Recommended Spare Parts section and provide the part number along with the required quantity in addition to the name plate data of the compressor.

### Warranty Information

The Company recommends that every Elgi compressor owner familiarize himself or herself with this warranty document. The warranty is explicitly/implicitly subjected to certain conditions. These are summarized here for the benefit of the owners.

The warranty is subjected to fulfilment inter alia of the following obligations by the purchaser/owner of the compressor.

- Proper installation of the compressor. This is the sole responsibility of the purchaser.
- Normal use and preventive maintenance as recommended by the compressor owner's operation manual supplied along with each compressor.
- Warranty will be applicable subject to use of Elgi genuine parts.
- Warranty as expressed/implied shall stand to exist only when the equipment is registered with dealer/Elgi plant.

## User Information

### Warranty Information . . .

- In case any defects are noticed, it would be a worthwhile effort on the owner's part to satisfy himself or herself in the first instance that the defect could be reasonably deemed to be of workmanship or material and that the compressor was never subjected to conditions in respect of which the warranty has been expressly negated.
- Any attempt to tamper with, or interchange any parts between, compressors shall void the warranty. The company has a record of each compressor and parts utilized thereon duly coded.
- Warranty claims related to the engine would be made directly to the engine manufacturer at their respective regional centres only. This is in line with an agreement arrived between Elgi and the engine manufacturer. Refer to the engine manufacturer's warranty conditions (given along with the sale documents) as per international warranty terms and conditions.
- Engines, oil coolers, radiators, separator elements, etc., not manufactured by us are usually warranted by the respective manufacturers. This shall however be applicable as expressed/implied for warranty as per manufacturer's guidelines of maintenance/operation/usage.
- The maintenance of the equipment has to be strictly logged in the log book and preserved, and the log book shall be shown at any time when demanded by an Elgi authorized representative.
- To analyse the cause for compressor failure, or for any major failure, the entire rig/compressor package is to be brought to the place of service to be rendered, i.e., factory or regional service centre or dealer's or agent's premises.
- Used products, and products not assembled by Elgi, are sold as is with no representation or warranty, and all warranties of quality, written, oral or implied, other than may be expressly agreed to by Elgi in writing, including without limitation, warranties of merchantability or fitness, are hereby disclaimed.

## User Information

### Warranty Information . . .

- In no event shall Elgi be liable for special, indirect, incidental or consequential damages however arising, whether in warranty, strict liability, contract, tort, negligence or otherwise, including but not limited to loss of profits of revenue, loss of total or partial use of the products, facilities of services, downtime costs or claims of purchaser for such or other damages whether on account of products furnished hereunder or delays in delivery there of will not be Elgi's liability.
- Elgi's liability on any claim, whether in warranty, strict liability, contract, tort, negligence or otherwise, for any loss or damage arising out of, connected with or resulting from this warranty or the performance or breach thereof, or from the design, manufacture, sale, delivery, resale, repair, replacement, installation, technical direction of installation, inspection, serving, operation or use of any product covered by or furnished under this warranty shall in no case exceed the purchase price allowable to the product or part thereof which gives rise to the claim.
- Notice of claims against Elgi hereunder for any reason, including breach of warranty, must be made to Elgi in writing within forty-eight (48) hours of discovery to afford Elgi the opportunity to make a prompt investigation of the surrounding facts and mitigate any damage which might ensue, should it be determined to be Elgi's responsibility. Failure to give such notice to Elgi shall constitute a waiver by purchaser of any right later to assert such a claim.
- Any cause of action against Elgi arising out of or relating to the warranty or the performance hereof shall expire unless brought within two (2) years of the time of actual thereof. Please refer Warranty / Service Log Book for detailed warranty instructions for major components.
- We provide warranty for the following equipment for a period of THIRTY MONTHS from the date of supply or twelve months from the date of commissioning whichever is earlier against defective material and bad workmanship and is valid only when the product is used in accordance with the manufacturer's instructions as stated in the Operation & Maintenance Manual.

## User Information

### Warranty Information . . .

#### Warranty Does Not Apply To

- Any compressor that shall have been subject to overspeeding, misuse, negligence or accident.
- a If the compressor is not commissioned by Elgi/ authorised person and duly not recorded in the Customer Maintenance Log Sheet.
- b Failures in any way resulting from use of parts not manufactured or approved by us.
- c Normal maintenance services including but, not limited to compressor tune up and the repair or replacement of filters, compressor and other normal maintenance spares.
- The months/hours criteria would work on "whichever is earlier" system from the date of invoicing the unit to the original user.
- The Commissioning of compressor shall be done only by Elgi/Authorised persons, after due verification of sale documents of compressor and duly recorded in the log book
- Wherever Hour Meter reading is not available for warranty claims determination, computation of total hour worked would be based on an average working of 10 hours per day from the date of invoice. In case, exclusion of downtime on account of major breakdown is required, necessary documentary proof and log book would be verified for the downtime claimed
- Warranty claims must be supported by purchase vouchers for spares like Air filters/ Oil filters, compressor oil etc, procured through Elgi outlet Annexure V. This should correspond to the recommendation of the manufacturer in terms of quantity, interval of change and source of purchase and proper recording to be maintained as per Annexure/111.
- In respect of units working away from place of sale, they should receive necessary service & spares on chargeable basis, from the branch/ regional offices, which is proximate to the working site of the unit. Warranty claim should be filed with the branch who made the sale along with purchase vouchers, service report from branch/regional office which rendered

## User Information

### Warranty Information . . .

service and the failed components should be sent to the Head Office located at M/s. Elgi Equipments Limited, Trichy Road, Singanallur, Coimbatore - 641 005 within a period of 15 days from the date of service report. Any warranty claim made beyond this stipulated time, would not be entertained. The statutory levies so incurred during part replacement shall not be refunded when considered for warranty.

- We make no warranty as to normal wear and tear, nor do we agree to be liable for loss of time to the used while the compressor or other equipment is out of commission, nor for any labour or other expense, damage or loss occasioned, or claimed to be occasioned by such defective parts.
- Any claim or obligation in connection with the sale of our compressor shall be subject to the jurisdiction of the courts in Coimbatore.
- The Company make no warranties expressed or implied relating to the sale of Elgi's genuine replacement parts.
- The Companies warranty practice with respect to allowances made for material, labour or miscellaneous expenses associated with the repair of a failure involving genuine Elgi's replacement parts is beyond the Company's legal obligation.

## User Information

### Handling Compressor

- Lift the compressor using the lifting bail.
- Prior to lifting, inspect the lifting bail and points of attachment for cracked welds and for cracked, bent, corroded or otherwise degraded members and for loose bolts and nuts.
- Make sure the lifting hook has a functional safety latch, or equivalent, and is fully engaged and latched on the bail.
- Use guide ropes or equivalent to prevent twisting or swinging of the machine once it has been lifted clear of the ground.
- Do not attempt to lift in high winds.
- Keep all personnel out from under and away from the compressor when it is suspended.
- Lift the compressor no higher than necessary.
- Keep the lift operator in constant attendance whenever the compressor is suspended.

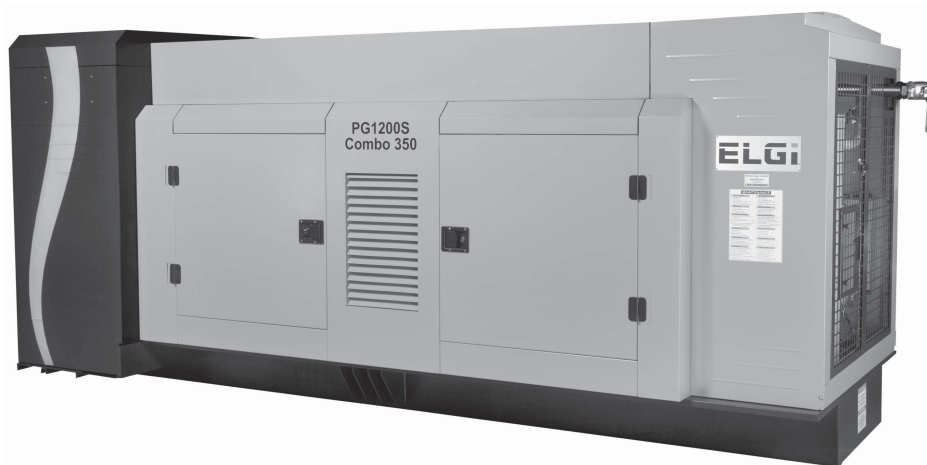

**PG 1200S-Combo 350 (Domestic / International) /  
PG 1200S - 330 / PG 1100S - 300**

## User Information

### Nomenclature of Models

DS – Diesel-powered skid model

DT – Diesel-powered trolley model

#### **EXAMPLE:**

In PG 1200S-Combo 350

PG – Portable Global

1200 – 1200 CFM (Flushing)

S – Skid type

350 – Maximum Pressure (psi)

### Compressor Location

Please observe the valid accident prevention regulations when installing this screw compressor.

Install the compressor with adequate accessibility to ensure obstruction-free operation and maintenance.

The area around the compressor should be clean, dry, cool and free of dust. Excessively warm intake air affects the compressed air output. The ambient temperature should not drop below -5°C.

When the ambient temperature is below -5°C, the compressor should not be operated. For assistance/clarifications on cold start kits and other arrangements, please contact Elgi India.

## Safety

Elgi designs and manufactures its products for smooth and safe operation. However, the responsibility for safe operation rests with those who use and maintain these products. The following safety precautions and devices are offered as a guide and accessories, respectively. These when followed will minimize the accidents and failures through out the useful life of the equipment.

Only those who have been trained and delegated to do so and who have read and understood this operation and maintenance manual should operate the air compressor. Failure to follow the instructions, procedures and safety precautions given in the manual may increase the possibility of accidents and failures.

Refer to the operation and maintenance manual of the engine and follow the instructions as given by the engine manufacturer.

- Never start an air compressor unless it is safe to do so. Do not attempt to operate an air compressor with a known unsafe condition. Tag the air compressor and render it inoperative by disconnecting power supply so that others who may not know of the unsafe condition will not attempt to operate it until the condition is corrected.
- This Elgi screw compressor is not explosive-proof and is not to be operated in explosive areas.
- Do not modify the compressor except with written approval from the factory.
- Please verify that the exhaust line rain cap/flap is closed properly after shutting down the compressor. It is the responsibility of the customer to avoid rain water entry into the engine.

### Follow the safety instructions

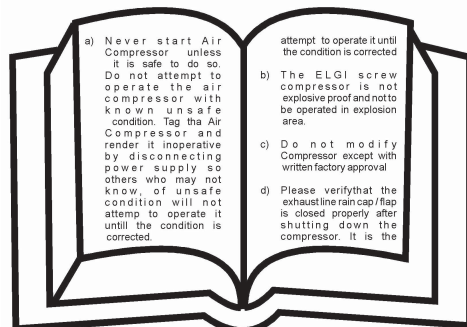

## Safety

### Pressure Release

- Manually pop up the pressure relief valve when the compressor is operating, at least weekly, to make sure the pressure relief valve is not blocked, closed, obstructed or otherwise inoperative.
- 
- Do not use tools that are rated below the maximum rating of this compressor. Select tools, air hoses, pipes, valves, filters and other fittings accordingly. Do not exceed the manufacturers' rated safe operating pressure for these items.
  - Secure all hose connections by wire, chain or other suitable retaining devices to prevent tools or hose ends from being accidentally disconnected.
  - Open the oil fill cap only when the compressor is not running and is not pressurized. Shut down the compressor and bleed the receiver tank to zero internal pressure before removing the cap.
  - Vent all internal pressure prior to opening any line, fitting, hose, valve, drain plug, connection or other component, such as filters.
  - Keep personnel out of line with and away from the discharge end of hoses or tools or other points of compressed air discharge.
  - Do not use air at a pressure higher than 2.5 kgf/cm<sup>2</sup> for any cleaning purposes.
  - Do not engage in horseplay with air hoses as death or serious injury may result.
  - Do not remove the radiator pressure cap until the coolant temperature is below its boiling point. Loosen the cap slowly to relieve any excess pressure and make sure that the coolant is not boiling before removing the cap completely.

## Safety

- After stopping the engine, confirm that the pressure gauge indicates 0 bar and before starting repair and maintenance. Residual air under pressure will blow off and severely injure the operator.
- Under any circumstance, do not open the oil fill cap of the separator receiver tank while running or immediately after stopping operation. It is very dangerous because the oil filler could be blown off and high-temperature compressed air and oil could jet out from the filler port and cause serious injury.
- When you refill the separator receiver tank with compressor oil, stop the engine and make sure that the pressure gauge indicates 0 bar and that there is no residual pressure in it, and then gradually loosen the oil filler cap for refilling oil.
- Do not connect the compressor air line to any air receiver directly without proper grouting and foundation of air receiver. Any hose line needs to be secured by wires/chain or other suitable retaining devices to pressure tools and hose ends from being accidentally disconnected.

### Fire and Explosion

- Clean up spills of lubricant or other combustible substances immediately if spills occur.
- Shut off the air compressor and allow it to cool. Keep sparks, flames and other sources of ignition away and do not permit smoking in the vicinity when checking or adding oil/fuel.
- Do not use flammable solvents for cleaning purposes.
- Keep electrical wiring and other terminals in good condition. Replace any wiring that has cracked, cut, abraded or otherwise degraded insulation; keep all terminals clean and tight.



## Safety

- Keep grounded conductive objects such as tools away from exposed live electrical parts such as terminals to avoid arcing, which might serve as a source of ignition.
- Keep oily rags, trash, dry leaves, litter or other combustibles out of and away from the compressor.
- Do not operate the compressor without a proper flow of cooling air/ cooling water or with an inadequate flow of lubricant or with a degraded lubricant.
- Do not attempt to operate the compressor in any class of hazardous environment unless the compressor has been specially designed and manufactured for explosive applications.
- Disconnect the grounded (negative) battery connection prior to attempting to any repairs or cleaning inside the compressor enclosure. Tag the battery connection cable so that others will not accidentally reconnect it.
- Switch off the battery charger before making or breaking connections to the battery.
- Keep flames away from the battery because the battery may generate hydrogen gas and may explode.
- Under any circumstance, do not bring lit cigarettes or matches near such oils as engine oil and compressor oil.
- Replace damaged fuel tanks or lines immediately rather than attempting to weld or otherwise repair them. Do not store or attempt to operate the compressor with any known leaks in the fuel system.
- Such parts as mufflers and exhaust pipes can be extremely hot. Remove twigs, dried leaves, dried grass, waste paper, etc., from the exhaust outlet of the muffler.



## Safety

- Be sure to perform periodical checks of the compressor oil and oil separator. Neglecting checks could cause overheating of the oil, resulting in a fire.
- Open all the access doors and ventilate the enclosure prior to attempting to start the engine.
- Have fire extinguishers near the unit, ready for emergency situations.

### Battery Safety

- Never wash the battery with pressurized water.
- Never top up with acid/mineral water/tap water/stream water.
- Never apply grease on terminals/cable clamps.
- Never remove electrolyte, and never overfill the battery.
- Never hammer down the clamps on the terminals.
- Never operate the vehicle or charge the battery if the electrolyte temperature exceeds 60°C.
- Never short the battery terminals directly with a cable.
- Never do any welding work while charging.
- Never allow the batteries to run the vehicle with the specific gravity below 1.19.
- Never operate vehicles with batteries of two different specific gravity values.
- Never run vehicles with the vent plugs open.
- Never recharge the battery without topping up to the maximum level.
- Do not connect any other power connections for local lighting/rig lighting or any other purpose from this battery connection.

# Safety

## Moving Parts

Decals are fitted on the compressor to identify moving/rotating parts.

- The compressor is designed for running with the enclosure doors closed. Ensure that no loose parts are kept inside and that all doors are closed before starting the compressor.
- Keep hands, arms and other parts of the body as well as clothing away from couplings, fans and other moving parts during any checking/testing.
- Do not attempt to operate the compressor with the fan, coupling or other guards removed.

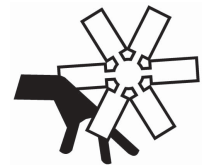

### DANGER



Death or serious injury may result from inhaling compressed air without using proper safety equipment.

- Wear snug-fitting clothing and confine long hair when working around the compressor, especially when hot or moving parts are exposed.
- Keep access doors, if any, closed except when making repairs or adjustments.
- Make sure all personnel are out of and/or clear of the compressor prior to attempting to start or operate it.



## Safety

- Disconnect and lock out all power at source and verify at the compressor that the circuits are de-energized to minimize the possibility of an accidental start-up or operation, prior to attempting repairs or adjustments. This is especially important when the compressor is remotely controlled.
- Keep hands, feet, floors, controls and walking surfaces clean and free of fluid, water or other liquids to minimize the possibility of slips and falls.
- Make adjustments only when the engine is shut off.
- Keep hands away from rotating parts or belts. If hands are caught they can be seriously injured.



### Hot Surfaces

**Decals are fitted on the exposed hot surfaces of the compressor.**

- Avoid bodily contact with hot oil, hot coolant and hot surfaces.
- Keep all parts of the body away from all points of air discharge.
- Wear personal protective equipment including gloves and head coverings when working in, on or around the compressor.
- Keep a first-aid kit handy. Seek medical assistance promptly in case of injury. Do not ignore small cuts and burns as they may lead to infections.



## Safety

- Under any circumstances, do not open the radiator cap while the machine is running or immediately after stopping operation. High-temperature steam jets out when this is done, and this could cause scalding.
- After stopping the engine, wait for 10 to 20 minutes until the engine oil cools down. Then check the level of the engine oil, or refill or drain the oil. Engine oil is very hot and highly pressurized during or just after operation. Hot oil could blow out of the tank and can cause scalding.

### Toxic and Irritating Substances

- Do not use air from this compressor for respiration (breathing).



- Exhaust gas from the engine is poisonous and could cause death when inhaled. Avoid using the machine in an insufficiently ventilated building or tunnel.

- Oils, coolants and lubricants used in this compressor are typical of the industry. Care should be taken to avoid accidental ingestion and/or skin contact. In the event of ingestion, seek medical treatment promptly. Wash with soap and water in the event of skin contact.



- Never blow compressor air directly towards people. Scattered impurities, dust and foreign objects in the compressed air may cause skin and eyes to be seriously injured.



- When the machine has to be unavoidably temporarily operated with its port open, be sure to mount a silencer to reduce the noise, and wear protective items such as ear plugs to prevent damage to hearing.

#### **DANGER**



Death or serious injury may result from inhaling compressed air without using proper safety equipment.

## Safety

### Electrical Shock

- Keep all parts of the body and any hand-held tools or other conductive objects away from exposed live parts of the electrical system. Maintain a dry footing, stand on insulating surfaces and do not contact any other portions of the compressor when making adjustments or repairs to exposed live parts of the electrical system. Make all such adjustments or repairs with one hand only so as to minimize a current path through the heart.
- Attempt repairs only in clean, dry and well-lit and ventilated areas.
- Keep the towing vehicle or equipment carrier, compressor, hoses, tools and all personnel at least 10 feet from power lines and buried cables.
- Disconnect, lock out and tag all the power lines prior to attempting repairs or adjustments to the machinery and prior to handling any ungrounded conductors.

### Lifting

- The compressor is provided with a lifting bail ("2"). Ensure that the compressor is lifted using the lifting provided. Use slings of adequate capacity to lift the compressor more than 3 metres above the ground level or to transport the compressor using a helicopter.

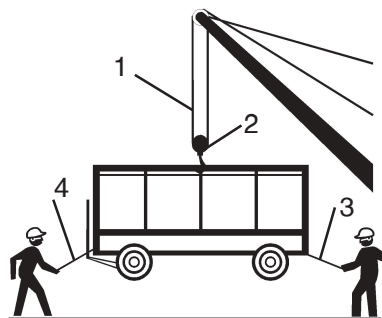

- Prior to lifting, inspect the lifting bail and points of attachment for cracked welds and for cracked or bent or corroded or otherwise degraded members and for loose bolts or nuts.
- Make sure that the entire lifting, rigging and supporting structure has been inspected, is in good condition and has a rated capacity of at least the net weight of the compressor plus an additional 10% allowance for the weight of mud or stored tools and equipment. Weigh the compressor if you are not sure of the total weight.

## Safety

- Make sure the lifting hook (“1”) has a functional safety latch or equivalent and is fully engaged and latched on the lifting bail.
- Use guide ropes or equivalent materials (“3”) to prevent twisting or swinging of the machine once it has been lifted clear of the ground.
- Do not attempt to lift in high winds.
- Keep all personnel away from below the compressor when it is suspended.
- Do not lift the compressor higher than necessary.
- Keep the lift operator in constant attendance when the compressor is suspended.
- Set the compressor down only on level surfaces capable of supporting at least its net weight plus an additional 10% allowance for the weight of mud or stored tools and other equipment.

## Safety

### C) Parking or Locating Compressor

- Park or locate the compressor on a levelled area, if possible. If not, park or locate the compressor across the gradient so that the compressor does not tend to roll downhill. Do not park or locate the compressor on a land gradient exceeding 15° (27%).
- Make sure that the compressor is parked or located on a firm surface that can support its weight.
- Park compressors such that the wind tends to carry the exhaust away from personnel and away from the compressor air inlet openings and where the compressor will not be exposed to excessive dust from the work site.
- If chains are provided, unhook and remove them from the points of chain attachment on the towing vehicle; then hook the chains to the ball on the drawbar or wrap chains around the drawbar and hook them to themselves to keep the chains off the ground so that rusting is not accelerated.
- If a front screw lock is provided, lower it and/or any rear stabilizer legs. Make sure that the surface they contact has the load-bearing capability to support the weight of the compressor.
- Keep feet clear of the drawbar at all times to avoid crushing accidents in case it should slip from your hands or otherwise fall to the ground.
- Move the towing vehicle clear of the parked compressor and erect hazard indicators, barricades and/or flares (if at night) if the compressor is parked on or adjacent to public roads.

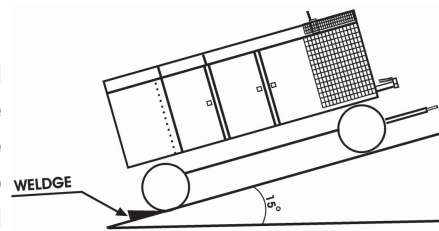

While skid-mounted portable air compressors are not towed in the usual sense of the word, many of these recommendations are directly applicable to them as well.

## Safety

### Entrapment

- Make sure all personnel are out of the compressor before closing and latching enclosure doors.
- If the compressor is large enough to hold a man, and if it is necessary to enter it to perform service or adjustments, inform other personnel before doing so, or else secure the access door in the open position to avoid the possibility of others closing and latching the door with personnel inside.



### Jump-Starting

- Observe all the safety precautions mentioned elsewhere in this manual.
- Batteries may contain hydrogen gas, which is flammable and explosive. Keep flames, sparks and other sources of ignition away.
- Batteries contain acid, which is corrosive. Do not allow battery acid to contact eyes, skin, fabrics or painted surfaces as serious personal injury or property damage could result. Flush any contacted areas thoroughly with water immediately. Wear an acid-resistant apron and face shield when attempting to jump-start the compressor.
- Remove all vent caps from the battery or batteries in the compressor. Do not permit dirt or foreign matter to enter the open cells.
- Check the fluid level. If it is low, bring it to the required level before attempting to jump-start.
- Do not attempt to jump-start if the fluid is frozen or slushy. Bring batteries up to at least 40°F (5°C) before attempting to jump-start.
- Cover open cells of oil compressor batteries with clean, damp cloths before attempting to jump-start.
- Attempt to jump-start only with a vehicle with a negative ground electrical system with the same voltage and that is equipped with a battery or batteries of comparative size or larger than that supplied with the compressor. Do not attempt to jump-start using motor generator sets, welders or other sources of DC power as serious damage may result.

## Safety

- Bring the starting vehicle alongside the compressor; do not permit metal-to-metal contact between the compressor and the starting vehicle.
- Set the parking brakes of both the compressor (if provided) and the starting vehicle on or otherwise block both sides of all wheels.
- Place the starting vehicle in neutral or park, turn off all non-essential electrical loads and start the engine.
- Use only jumper cables that are clean, in good condition and are heavy enough to handle the starting current.
- Avoid accidental contact between the jumper cable terminal clips or clamps and any metallic portion of either the compressor or the starting vehicle to minimize the possibility of uncontrolled arcing which might serve as a source of ignition.
- Positive battery terminals are usually identified by a plug (+) sign on the terminal and the letters POS adjacent to the terminal. Negative battery terminals are usually identified by the letters NEG adjacent to the terminal.
- Check your connections. Do not attempt to start a 24V compressor with one 12V battery in the starting vehicle.
- Start the compressor in accordance with the normal procedure. **Avoid cranking for more than 5 seconds continuously.**
- Remove and carefully dispose of the damp clothes as they may be contaminated with acid. Replace the oil vent caps.

### Service Line Hose Connection

Do not connect a high-pressure air service line with a hose and air receiver arrangement without proper mounting of the air receiver and hose line.

## Do's and Don'ts

### Do's

- Read the manual in detail and follow the instructions.
- Clean the air compressor package regularly.
- Keep the air filter clean.
- Use only genuine Elgi spares.
- Use only clean and recommended lubricants.
- Maintain the correct oil level.
- Use proper tools.
- Attend immediately to anything unusual relating to the air compressor.
- Maintain a log book to monitor the operation of the compressor.
- Attend o repairs/service with qualified technicians only.
- Please check that the exhaust line flap is closed properly after the compressor is shut down.

### Don'ts

- Neglect routine attention.
- Allow any leakage in the system.
- Keep any tools or loose items on the compressor/other modules.
- Meddle with any adjustments or settings.
- Use cleaning agents when changing oil.
- Do any repair work while the unit is running.
- Overload the compressor for a long period, even though it is of continuous rating, as we recommend intermittent use only.

## **Salient Features and Specifications**

### **Salient Features**

#### **Less Maintenance**

A screw compressor has only two moving parts-the rotors-which do not touch each other as they are kept apart by means of a thin film of oil and hence there is not wear and tear. There are no reciprocating parts such as pistons, piston rings and connecting rods and no suction or discharge valves to be maintained.

#### **Maximum Reliability**

With only two rotors, moving at a conservative speed, screw compressors provide a level of reliability never before attained in the history of the compressor industry.

#### **Low Discharge Temperature**

The heat of compression is taken away from the point of origin to the cooler by the injected oil, and hence the discharge temperature does not exceed 90°C. No carbonized oil is therefore formed in the compressor and in the system.

#### **Small Package**

Because of the unique way in which the screw compresses the air, a complete air package is provided with modest overall dimensions.

#### **Low Noise and Free of Vibrations**

There are no reciprocating masses. There are only rotating parts which are dynamically balanced.

#### **Long Life**

Since there is no metallic contact between the rotors and the housing, and they are flooded with oil, no wear or reduction in output capacity/performance occurs even after many years of operation.

## **Salient Features and Specifications**

### **No Loss in Capacity**

There is no wear in the solid steel screws. Thus there is no loss in performance due to wear. The compressor provides the same air flow, no matter what its age is.

### **Pulsation-Free Flow**

The continuous flow of air through the helical cavities in the screw and the continuous compression ensure pulsation-free compressed air delivery.

### **Air Quality**

The unique tangential air-oil separation system of the compressor ensures efficient separation of oil particles with a minimal pressure drop from the compressed air-oil mixture delivered at the compression end. The tangential system ensures a consistent quality of air during normal running and unloading cycles.

### **Low Operating Cost**

The operating cost of a screw compressor is generally less than those of other conventional machines.

### **Daul Pressure**

The compressor can be operated with two pressure ratings 325 and 350 Psi respectively depending up on the Hammer requirements

## Application Details

This model **PG 1200S-Combo 350 (Domestic / International) / PG 1200S - 330 / PG 1100S - 300** is recommended for (6"- DTH Hammer)  
- 6 1/2" DTH drilling



**DTH drilling - General**

A drilling rig is a machine which creates holes (usually called boreholes) and/or shafts in the ground. Drilling rigs can be massive structures housing equipment used to drill water wells, oil wells, or natural gas extraction wells or they can be small enough to be moved manually by one person. They sample sub-surface mineral deposits, test rock, soil and groundwater physical properties, and also can be used to install sub-surface fabrications, such as underground utilities, instrumentation, tunnels or wells

Drilling rigs can be mobile equipment mounted on trucks, tracks or trailers, or more permanent land or marine-based structures (such as oil platforms, commonly called 'offshore oil rigs' even if they don't contain a drilling rig). The term "rig" therefore generally refers to the complex of equipment that is used to penetrate the surface of the earth's crust.

## Application Details

### Types of DTH Drilling.

- Keep feet clear of the drawbar at all times
- Water Well Drilling
- Geothermal Drilling (Heating)
- Geothermal Drilling (Power Plants)
- Exploration Drilling
- Blast-hole Drilling
- Dimensional Stone Quarries
- Geotechnical Drilling
- Horizontal Drilling
- Oil & Gas
- Coal Bed Methane
- Nitrogen Plants
- Pipeline Testing
- Deep-Water Berths
- Seismic Surveys

## Specification Sheet - PG 1100S - 300

No.	Description	Unit	Data
01	Model (skid mounted)		PG 1100S -300
02	Duty cycle		Intermittent
03	Free air delivery (Max.)	cfm (m <sup>3</sup> /min)	1100 (31.1)
04	Working pressure	PSIG (kg/cm <sup>2</sup> )	300 (21.0)
05	Unloading pressure	PSIG (kg/cm <sup>2</sup> )	315 (22.1)
06	Airend Model.		284/159 Axis airend
07	No. of stages		Two
08	Engine make		CUMMINS India Ltd.,
09	Engine model		NTA-855C BigCam, water cooled with Plastic Fan
10	Rated operating speed	rpm	1800 (+30)
11	Drilling speed	rpm	1600 (+25)
12	Min. operating speed	rpm	1200 (+50)
13	Engine power output (Net)	hp	415
14	Reference conditions-ambient & altitude	Deg. C & Mtrs	5°C -50°C & 2286 Mtrs
15	Additional Accessory on Engine		Refer Engine scope
16	Engine Lube oil capacity	Lit.	40
17	Engine coolant capacity with Radiator	Lit	70
18	Capacity of seperator tank (full)	Ltrs	307
19	Oil fill capacity (Initial/Refill)	litres	135 / 10
20	Total oil fill capacity	Ltrs	145 (+10)
21	DOT(Ambient <30)	Deg C	Amb + 66 to 80
22	DOT(Ambient 30 to 40 Deg C)	Deg C	Amb + 63 to 70
23	DOT(Ambient > 40 Deg C)	Deg C	Amb + 58 to 65
24	Air outlet port size & Qty	Inches &Nos	2", 1 No
25	Sound Pressure Level of the Compressor	dB (A)	92 (+3) dB(A) at 7 meter
26	Overall dimensions (LXBXH)	mm	4800 X 2200 X 1950
27	Ref. standard for FAD		ISO 1217:1996 Annex D
28	Ref. standard for noise level		ISO 3744
29	Net weight	kg	5200 (±50)

## Specification Sheet - PG 1200S-Combo 350 (Domestic / International)

No.	Description	Unit	Data
01	Model (skid mounted)		PG 1200S-Combo 350
02	Duty cycle		Intermittent
03	Free air delivery (Max.)	cfm (m <sup>3</sup> /min)	1200 (34)
04	Working pressure	PSIG (bar g)	350 (24.2)
	Optional pressure		325(22.4)@1600 rpm
05	Unloading pressure	PSIG (bar g)	365 (25.2)
06	Airend SPL no.		X990370
07	No. of stages		Two
08	Engine make		CUMMINS India Ltd.,
09	Engine model		NTA-855C BigCam, water cooled with Plastic Fan
10	Rated operating speed	rpm	1800 (+30)
11	Drilling speed	rpm	1660 (+25)
12	Min. operating speed	rpm	1200 (+50)
13	Engine power output (Net)	hp	415
14	Reference conditions-ambient & altitude	Deg. C & Mtrs	5°C -50°C & 2286 Mtrs
15	Engine Lube oil capacity	Lit.	40
16	Engine coolant capacity with Radiator	Lit	70
17	Battery capacity, Qty.	V, Ah, nos.	12, 180, 2 Nos
18	Capacity of separator tank (full)	Ltrs	307
19	Oil fill capacity (Initial/Refill)	litres	135 / 10
20	Total oil fill capacity	Ltrs	145 (+10)
21	DOT(Ambient <30)	Deg C	Amb + 68 to 78
22	DOT(Ambient 30 to 40 Deg C)	Deg C	Amb + 65 to 70
23	DOT(Ambient > 40 Deg C)	Deg C	Amb + 60 to 65
24	Air outlet port size & Qty	Inches & Nos	2", 1 No
25	Sound Pressure Level of the Compressor	dB (A)	92 (+3) dB(A) at 7 meter
26	Overall dimensions (L x B x H)	mm	4800x 2200 x 1950
27	Ref. standard for FAD and SFC		ISO 1217:1996 Annex D
28	Ref. standard for noise level		ISO 3744
29	Net weight	kg	5200 (±50)

## Specification Sheet - PG 1200S - 330

No.	Description	Unit	Data
01	Model (skid mounted)		PG 1200S-330
02	Duty cycle		Intermittent
03	Free air delivery (Max.)	cfm (m <sup>3</sup> /min)	1200 (34)
04	Working pressure	PSIG (kg/cm <sup>3</sup> )	330 (23.2)
05	Unloading pressure	PSIG (kg/cm <sup>3</sup> )	345 (24.2)
06	Airend SPL no.		X990370
07	No. of stages		Two
08	Engine make		CUMMINS India Ltd.,
09	Engine model		NTA-855C BigCam, water cooled with Plastic Fan
10	Rated operating speed	rpm	1800 (+30)
11	Drilling speed	rpm	1600 (+25)
12	Min. operating speed	rpm	1200 (+50)
13	Engine power output (Net)	hp	415
14	Reference conditions-ambient & altitude	Deg. C & Mtrs	5°C - 50°C & 2286 Mtrs
15	Additional accessory on engine		Ref. Engine scope
16	Engine Lube oil capacity	Lit.	40
17	Engine coolant capacity with Radiator	Lit	70
18	Capacity of seperator tank (full)	Ltrs	307
19	Oil fill capacity (Initial/Refill)	litres	135 / 10
20	Total oil fill capacity	Ltrs	145 (+10)
21	DOT(Ambient <30)	Deg C	Amb + 68 to 78
22	DOT(Ambient 30 to 40 Deg C)	Deg C	Amb + 65 to 70
23	DOT(Ambient > 40 Deg C)	Deg C	Amb + 60 to 65
24	Air outlet port size & Qty	Inches & Nos	2", 1 No
25	Sound Pressure Level of the Compressor	dB (A)	92 (+3) dB(A) at 7 meter
26	Overall dimensions (L x B x H)	mm	4800x 2200 x 1950
27	Ref. standard for FAD and SFC		ISO 1217:1996 Annex D
28	Ref. standard for noise level		ISO 3744
29	Net weight	kg	5200 (±50)

# Installation

## General

The operating instructions given below are for commissioning standard version air-cooled series compressors without additional equipment. Before commissioning the equipment, check for visual damage of parts. An electrical circuit diagram is delivered with every compressor (kept inside the electrical control panel) for electrical wiring reference.

Every screw compressor is subjected to a test run and set prior to despatch. Transport damage at a later stage cannot however be excluded. Therefore, please observe the compressor closely during commissioning and the trial run.

## Installation Requirements

While installing the compressors, ensure the following:

- The compressor is kept on a levelled surface capable of withstanding the weight.
- Safe operation of the compressor is only ensured if the ambient temperature remains within the limits.
- A forced cool air flow should not be directed towards the compressor.
- The compressor is to be located such that hot air from other machines is not directed towards the compressor.
- Keep the compressor under cover to protect it from rain/storms.
- Provide a clearance space of 1.5 metres around the compressor.
- The battery supplied along with compressor package is not charged. You need to charge the batteries for 72 hours before commissioning.

**Note:**

If you fail to observe the instructions concerning installation and ventilation, the discharge temperature of the compressor may increase or decrease excessively and trip the compressor at high discharge temperature conditions. The output of the compressor will also be affected.

The compressor will not give warnings during short operating times. It will operate below the dew point, and moisture condensate will mix with the oil. This will reduce the lubricating qualities of the oil and lead to damage to the compressor.

## Installation

### Installation Guidelines for Skid Unit When Mounting on Truck

- **Truck mounting recommendations: Pusher-type fan arrangement**
- For a pusher-type fan arrangement, it is recommended that the ROC to be mounted away from driver's cabin.(ie.,) tank side to be mounted next to cabin.
- The minimum recommended gap between the compressor and the driver's cabin is min. 0.9 meter and max. 1 meter as shown in the picture below.
- The minimum recommended gap provided should be free of restrictions. It should not be occupied with hydraulic tanks, oil cans, hammer, drills etc.,
- **Fuel Tank Recommendations**

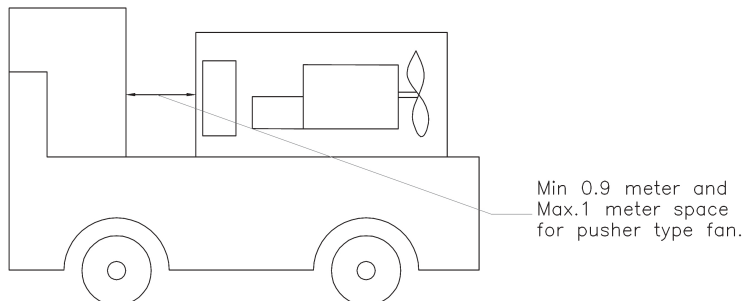

- The fuel tank is commonly sized for operation for one shift (8 hours).It is suggested that a 500 litre tank be provided for NTA855CBC.
- The tank should have a drain fitting with a ball valve to bleed off water condensate, accumulated dirt, etc. The use of a ball valve will avoid spilling over of diesel during cleaning.
- The breather opening should be provided to vent gases and air from the tank without a back-pressure being created. A suitable breather must be selected which will not allow the dust to get sucked into the tank.
- The filler cap and breather should be elevated to prevent mud or dirt from dropping into the tank. The fill neck should be extended inside the tank to an equivalent of 5% of the tank volume to provide for thermal expansion. A coarse fuel strainer (#80 mesh) should be provided in the fill neck to remove all coarse gravel, leaves, rags, etc.

## Installation

- The fuel pump suction line should pick up fuel about one inch above the bottom of the tank at its centre. A bottom opening should be avoided, as it is prone to damage from flying stones or other road hazards. Caution should be exercised to assure that there are no air leaks in this line and fittings as this may cause erratic engine behaviour.
- It is recommended that a baffle plate be provided with a hole between the fuel return and suction lines. The minimum distance recommended between the fuel supply and return lines is 12 inches.
- The return line discharge should be pointed away from both the breather and the suction areas. Direct the return flow against the side wall of the fuel tank.
- The tank should be clean and not prone to rust or corrosion.
- Appropriate cleaning of the tank should be done after welding to clean off any debris of slag, which might remain in the tank.
- A hand hole cover is to be provided on top for cleaning the tank.
- The location of the fuel tank should be such that it is away from any external heating source which may cause the fuel temperature to rise in excess of 160°F (71°C).

### General Recommendations

- The mast or hoses of the mast should not touch the air the intake piping.
- The mast or hoses of the mast should not touch the exhaust piping.
- The package should operate with all doors closed.
- Do not connect a high-pressure air service line with the hose and air receiver arrangement without mounting the air receiver and hose line properly.

### Connection of the Compressed Air Supply

The unit is set up and ready to operate. Connect the discharge outlet to the pipe line using a flexible hose or suitable arrangement according to the application.

## Installation

### Electrical Connection

- Ensure that only authorized electricians carry out the electrical work. Study the electrical circuit diagram before starting the work.
- The batteries supplied along with the compressor are not charged. Ensure that the batteries are removed from the unit, prepared suitably and charged.
- The electrical connections in the compressor are completed and tested at the factory before shipment. The wiring circuit diagram is supplied along with the compressor. Study the wiring diagram before providing the connection.
- Fix the batteries in position (after charging) and secure them. Connect the cables to the batteries as per the wiring diagram.
- Check the correctness of the connections first with a multi-meter and then by switching on the lamp in the compressor.
- Remove the battery connection when the compressor is not ready for starting. This is to ensure accidental starting by unauthorized personnel/ personnel unaware of the state of the compressor.

### Diesel Tank Mounting Position With Respect to Engine Pump Arrangement

For skid units the diesel tank is to be located so that the fuel level is no higher than the injectors and no lower than 6 feet below the fuel suction. Locate the fuel tank so that the fuel is not preheated by an external source. The fuel return line connection in the tank should be located to allow separation of the fuel and vapour or gases in the expansion space above the normal fuel line. It is suggested that the return line discharge be pointed away from both the breather and suction areas. Less agitation is created by mounting the return line against a side wall at a shallow angle.

### Pre-shipment Procedure for Compressor stored for more than six months

#### COOLANT SYSTEM

- Drain radiator water.
- Flush cooling system using air at a pressure of 5 psi.
- Block all the openings, if any, on the engine block.

## Installation

- Tell the customer to add antifreeze agent before starting the engine, along with the coolant.
- The antifreeze coolant specifications are provided subsequently.

### FUEL SYSTEM

- Drain all the diesel in inlet and return lines (In some cases the fuel leakage line need to be drained out)
- Fuel hose ends to be tightened or blocked with proper arrangement so that no moisture will enter into the system.
- Flush the system by air pressure of 10 psi.
- Block the opening in fuel system.
- Remove the fuel filter element

### LUBE OIL SYSTEM

- Drain all the oil from the pan.
- Flush the oil system at a pressure of 15 psi.
- Block all the openings, if any, in the lube system.
- Check the suitability of the oil before starting the engine.
- The specifications of the oil follow.
- Remove the used oil filter element including the bypass and place a new unused element in it and despatch.
- Care is to be taken at the time of commissioning to despatch the unit with a new filter element, and at the time of commissioning the element is to be taken out and immersed in oil and refitted so that the engine starts without any problem.
- This is applicable for fuel system filters also.

## Commissioning

Elgi ships the compressor unit without the compressor suction duct assembly, engine suction assembly and engine exhaust duct assembly. These are packed separately and shipped along with the unit. During commissioning you need to fix them on the unit before starting it.

On receipt of the compressor unit at your warehouse, please open the door and take the compressor manual bag, which is tied to the lifting bail pillar. In the compressor manual bag you will find the compressor manual, engine manual, compressor warranty card, engine warranty card, battery manual & battery warranty card, test certificate and packing slip.

The compressor door keys and panel keys are tied to the service line ball valve handle.

### Points to be Observed Before Initial Start

Every compressor is test run in the factory and carefully checked before shipment. The test run confirms that the compressor conforms to the specifications and runs perfectly. However, regardless of the checks carried out at the factory, the compressor could be damaged during transport. We recommend that the compressor be examined for such damage and if any damage is found that it be reported to the nearest dealer/Elgi Equipments Ltd.



**Attention**

Important functional components in the compressor (such as the minimum pressure valve, pressure relief valve, inlet valve, pressure switches and temperature switch) are adjusted and fitted. Alterations to these components are not allowed without prior consultation with the manufacturer.



The minimum pressure valve and pressure relief valve are spring actuated.

### Points to be Observed Before Starting



If these instructions (Warning, Attention) are not complied with, accidents can occur, causing injury to persons or damage to equipment.

## Commissioning

### Operate the compressor with doors kept open.

- The operator is expected to employ safe working conditions and to follow all prescribed operating and safety regulations while operating this compressor.
- The user of this compressor is responsible for its safe operating conditions.
- Do not operate this compressor under heavy dust conditions-toxic or inflammable gases could be present.
- Do not connect the compressor to a supply voltage other than that specified in the Technical Specifications section.
- Do not install the compressor in a place subject to freezing temperatures. The air temperature at the air intake must be above +5°C.
- Check the oil level in the receiver tank before starting the compressor. The oil level should be up to the middle of the oil sight glass provided on the receiver tank.
- Fill the recommended compressor oil to the middle of the oil sight glass on the receiver tank. The oil fill capacity of the compressor is 120 litres when the receiver tank is empty. The first-time fill should be to the middle of the sight glass only. The rest of the oil is to be added after the initial start only. Refer to the Initial Start instructions given in the following pages.
- Check and ensure that the oil filter elements are fitted properly.
- Open the air outlet line ball valve (provided on the front side of the compressor) fully before starting the compressor.
- Check the engine oil level by removing the dipstick provided on the engine block.
- Check the oil in the fuel injection pump.
- Check the coolant level in the radiator. Use a recommended coolant as per the engine manual.
- Check the belt tension of the engine fan drive. Refer to the engine manual for guidelines.

## Commissioning

- Check the diesel level in the diesel tank.
- Ensure that only authorized electricians carry out the electrical work. Study the electrical circuit diagram before starting the work.
- Ensure that the electrical supply is disconnected and check all the screws of the electrical connections for tightness (carry out this check again after 50 operating hours).
- Ensure that the battery connections are as per the wiring diagram.

### Preservation Procedures for Whole Package

#### General recommendations for product preservation ( upto 6 months )

##### Airend :

1. Remove the Butterfly valve at the suction of the airend.
2. Pour 4 litres of rust-preventive oil into the suction.
3. Change all oil filters
4. Remove the discharge plug after pouring rust-preventive oil to drain the oil.
5. After draining the rust-preventive oil from the airend, refit the discharge plug.
6. Close the suction using the Butterfly valve.
7. Carry out this procedure every three months until usage.
8. Use CORTEC369 rust-preventive oil or any equivalent oil available to you.
9. Change the Airend air filter.

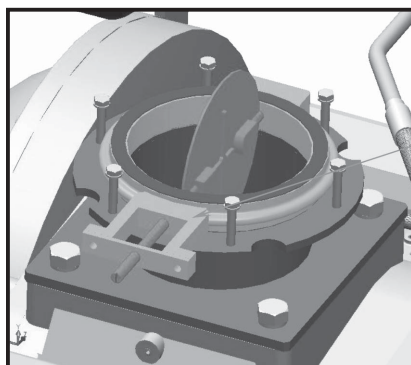

Butterfly valve

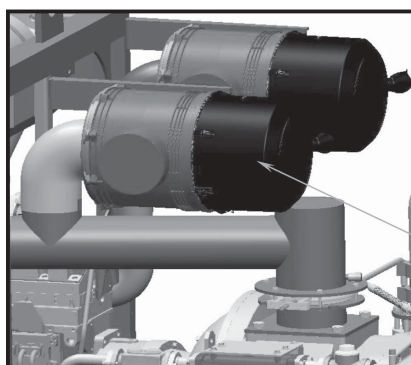

Air filter

## Commissioning

### Preservation Procedures for Whole Package

#### General recommendations for product preservation ( upto 6 months )

#### Engine :

1. Change the engine oil filter element.
2. Change the lube oil.

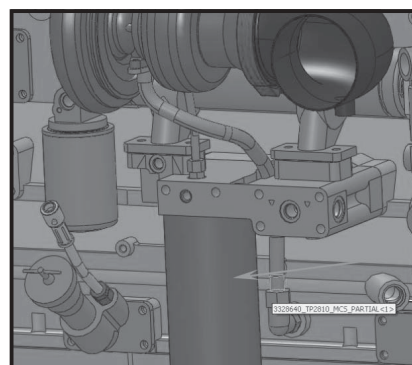

**Oil  
filter**

3. Change the fuel filter element.

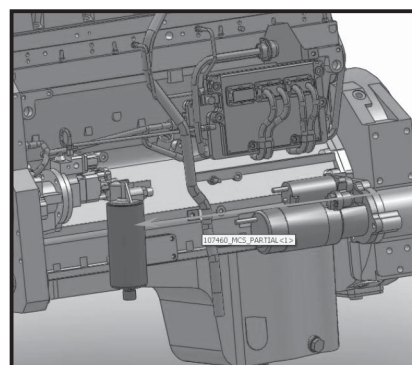

**Fuel  
filter**

4. Change the engine air filter.

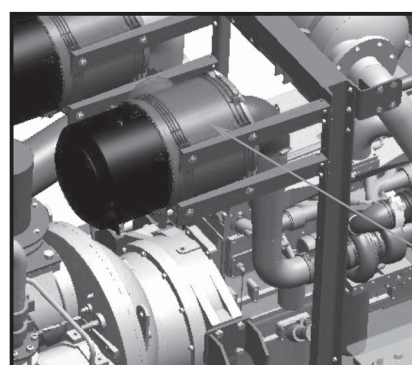

**Air  
filter**

## Commissioning

### Preservation Procedures for Whole Package

#### General recommendations for product preservation ( upto 6 months )

5. Replace the radiator coolant.
6. Remove the engine turbo oil line hose and lubricate it with engine oil.

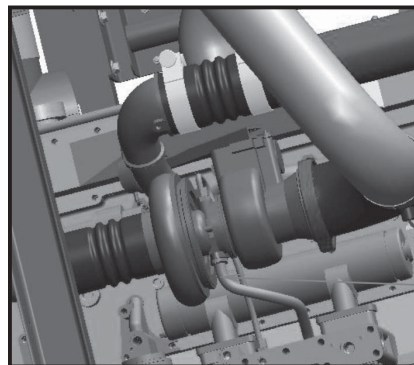

**Turbo  
oil drain**

7. Drain the radiator and flush it out.

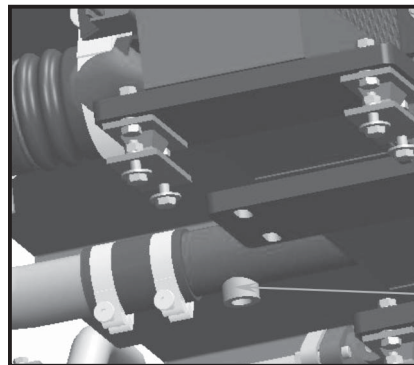

**Radiator  
coolant  
drain plug**

8. Inspect the fuel line non-return valve (NRV).
9. Remove the fuel tank drain and drain out the dust.

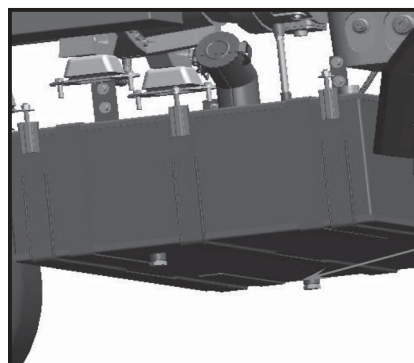

**Diesel  
drain**

## Commissioning

### Preservation Procedures for Whole Package

#### General recommendations for product preservation ( upto 6 months )

##### General :

1. Check for Engine and Air end mounting bolt tightness
2. Crank the engine without pressing over run key to ensure the free rotation.

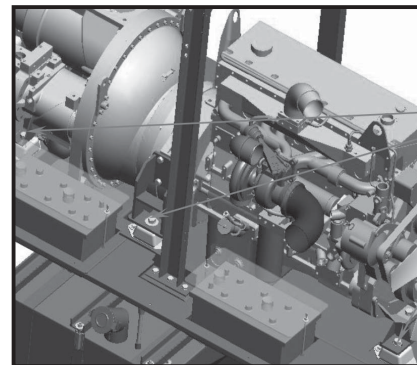

Engine and  
Airend  
mountings

3. Ensure the air filter indicator (both engine and Air end) indication to normal condition



Engine and  
Airend  
mountings

4. Ensure the mounting bolt tightness of bail lift assembly before lifting the package

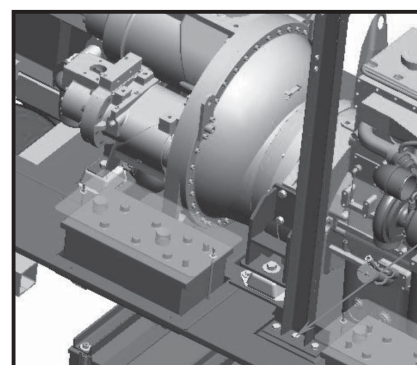

Bail lift assy  
mountings  
bolts

# Commissioning

## Preservation Procedures for Whole Package

### General recommendations for product preservation ( upto 6 months )

- 5. Clean the actuator assembly  
(Engine and Compressor)

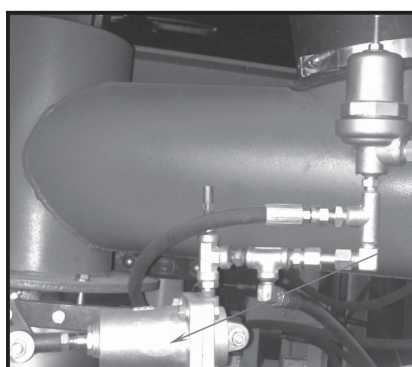

**Actuator assembly**

- 6. Clean MPV and BDV.
- 7. Ensure the tightness of all control system fittings to avoid leakage while compressor starting

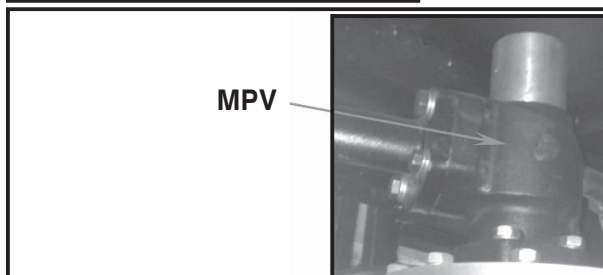

**MPV**

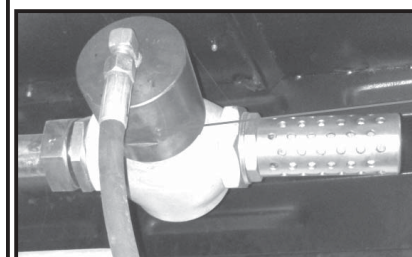

**BDV**

- 8. Compressor should be started with Start mode.
- 9. Check the safety valve sealing to ensure the setting pressure.
- 10. Flush out the coolant from radiator using compressed air
- 11. Flush out the oil from oil cooler using compressed air

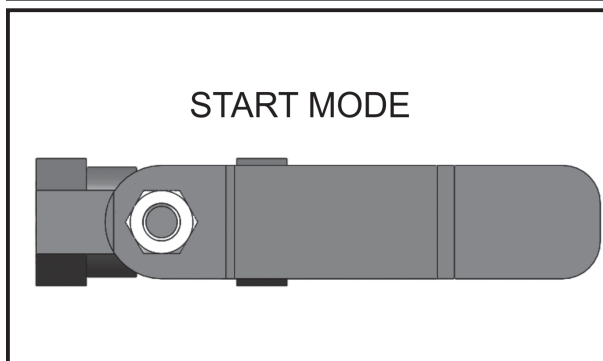

**START MODE**

## Commissioning

### Preservation Procedures for Whole Package

#### General recommendations for product preservation ( upto 6 months )

12. Fill with recommended fresh coolant and oil in ROC with the specified level
13. Remove Air oil separator and check for the visual defect, replace if any defect found.

14. Ensure the tank mounting bolt tightness

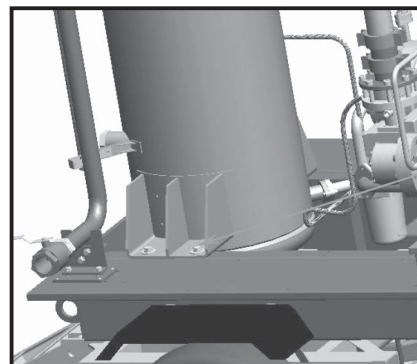

**Tank  
mounting  
bolts**

15. Ensure the all lubrication joint bolt tightness to avoid leakage while starting

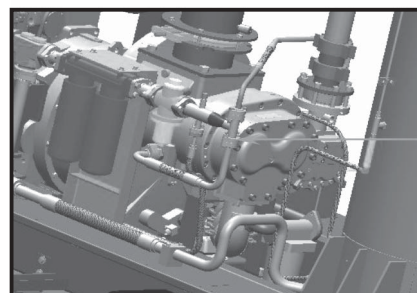

**Lubrication  
hose  
joints**

16. Check for electrical connections before starting the compressor

## Commissioning

### Preservation Procedures for Whole Package

General recommendations for product preservation  
( upto 6 months )

#### Pre requisites for commissioning

(a) Replace the below critical components if its shelf life has crossed as recommended in table below.

Sl.No.	Component Name	Shelf Life, in Months
1	Air filter Element	24*
2	Oil filter element	12*
3	Air Oil Separator Element	12*
4	Lubricating Oil	12
5	Rubber Hoses	24
6	Nylon tubes and fittings	12
7	Shaft Seal	36
8	Anti vibration mount (AVM)	36
9	Valves	24
10	Gauges	24
11	Switches	24

\*Air filter element, Oil filter element & Air Oil Separator element to be changed at the time of commissioning, if shelf life exceeds as stated in table above.

# Commissioning

## Checklist for Engine Preparation Before Commissioning

CHECK LIST FOR ENGINE PREPARATION BEFORE COMMISSIONING	
1	Fill/check the oil level in the Engine using the dipstick provided on the engine block. If required add oil so that it reaches the necessary level. Consult with the local Cummins representative for the right grade of oil.
2	Fill/check the water level in the engine radiator. Check with Cummins for the appropriate engine coolant.
3	Check/ensure that the end play of the engine crankshaft is 0.1 mm to 0.3 mm (refer to the engine manual for the procedure to be followed)
4	Check/ensure that the coupling bolts are tightened properly.
5	Ensure that the battery is charged for 48 hours before the compressor is commissioned.
6	Check/ensure that the battery terminals are connected properly.
7	Check the fan belt tension.
8	Check/ensure that the clamps holding the exhaust manifold on the silencer are tightened properly.
9	Check the engine air filter condition and clamps tightness.
10	Check/ensure that the engine bed mounting bolts are tightened properly.
11	Check/ensure that the engine fan shroud bolts are tightened properly.
12	Check the gap between the engine fan and the shroud gap and its position.
13	Check the engine belt tension and adjust its tightness.
14	Check the condition of the engine belt.
15	Check the engine tripping switches and their condition.
16	Check the condition of the radiator and oil cooler AVM.

## Commissioning

### Check list for Engine Running Performance

CHECK LIST FOR ENGINE RUNNING PERFORMANCE	
1	Check the engine lubrication oil pressure.
2	Check the engine water temperature.
3	Check whether the alternator is charging.
4	Check the RPM meter and its condition.
5	Check the hour meter and confirm that it is working.
6	Check whether the engine exhaust joint leaks.
7	Check the condition of the engine turbo.
8	Check whether there is any leakage in the suction line.
9	Check the tightness of the engine air suction rubber elbow.
10	Check whether the roof light condition is ok or not.
11	Check whether there is any leakage from the flanges and joints.

# Commissioning

## Compressor Re-commissioning Checklist

COMPRESSOR RE-COMMISSIONING CHECKLIST	
1	Check/clean air filter element.
2	Check/ensure that the clamps on the duct are tightened properly.
3	Check/ensure that the Mounting Bolts of Airend & engine are tightened properly.
4	Check/ensure that the cooler/radiator mounting bolts are tightened properly.
5	Check/ensure that the air-oil receiver mounting bolts are tightened properly.
6	Check/ensure that the canopy bolts are tightened properly.
7	Check/replace the bearing oil filter element.
8	Check the condition of the main oil filter element.
9	Pour new compressor oil into the air-oil receiver tank. The compressor oil fill capacity is 160 litres.
10	Check/ensure that the oil lubricating line on the airend is tightened properly.
11	Check/ensure that the pulse line to the oil stop valve is tightened properly.
12	Check/ensure that the pulse line to the blow down valve is tightened properly.
13	Check/ensure that the pulse line to the actuator is tightened properly.
14	Check/ensure that the pulse line to the regulator assembly is tightened properly.
15	Check/ensure that the actuator on the butterfly valve assembly is fitted properly.

## Commissioning

16	Check/ensure that the pulse lines to all the gauges are tightened properly.
17	Check for any loose connections on the electrical terminals on the control panel board.
18	Check/ensure that the oil hose is fitted properly.
19	Check/ensure that all the bolts of the trolley, base frame and wheels are tightened properly.
20	Check/ensure that there is no damage to the electrical cables to avoid a short circuit.
21	Check/ensure that all the safety interlock switches are intact, including the wiring.
22	Check for any loose connections in the electrical terminals on the tripping switches.
23	Check the compressor exhaust duct flap condition and its closing and opening positions. This is very important.
24	Check the condition of the door hinges.
25	Check whether the roof light condition is ok or not.
26	Check whether the air suction rubber elbow is tight.
27	Check/ensure that the clamps on the pre-filters are tightened properly.

## Commissioning

### Compressor Daily Maintenance Check List

COMPRESSOR DAILY MAINTENANCE CHECKLIST	
1	Drain moisture/water from the sump before starting the unit.
2	Drain moisture/water from the moisture filter (red colour) fitted on the tank.
3	Check and clean the air filter.
4	Check whether the exhaust line flap has been closed properly after the compressor has been shut down.
5	Check whether the compressor oil level is at the half mark of the glass before starting the unit.
6	Check the engine oil and radiator water coolant levels.

## Commissioning

### Compressor Routine Maintenance Checklist for spin-on type oil filters fitted modified units

Compressor Routine Maintenance Checklist	
1	The bearing oil filter (fitted above the second-stage airend) must be replaced after every 500 hours of operation
2	The oil must be changed after every 500 hours of operation.
3	The air filter must be replaced after every 500/1000 hours of operation as required.
4	The main oil filters 2 numbers must be replaced every 500 hours.
5	The separator element must be replaced every 1500 hours as warranted.
6	The return line filter to be replaced every oil change

## Commissioning

### Starting Procedure

- Install the compressor on a surface levelled using a spirit level.
- Switch on the power supply to the compressor. The switch is provided on the instrument panel.

Keep the ¼ th gate valve near the regulator should be kept parallel position ( it means we start the compressor in low pressure mode)

- Turn the ignition key and press the override button simultaneously for up to minimum pressure valve reaches to 7 bars..
- Check that the engine rotates clockwise when viewed from the fan side.

**Note :** If the engine does not start within 5 seconds, release the ignition key and override button.

- Restart the engine after an interval of 1 minute.
- Run the compressor for 1 minute to circulate the compressor oil.
- Five minutes after stopping the compressor, check the oil level in the receiver tank. After the fumes settled down, the oil level should be up to the half mark on the glass.
- Run the unit for 15 to 20 minutes and check for any leakage.

The oil level of the compressor should be checked after shutdown the compressor and air-oil fumes settled down completely. The oil level should be half glass visible.

- The settings of the pressure regulator, electrical protection devices, etc., are set at the factory during the testing before despatch.

The foregoing procedure must be followed during re-installation of the compressor at a new location.

If the compressor is stored for a longer period before commissioning, contact the Elgi service engineer for installation and commissioning services.

## Working Principle

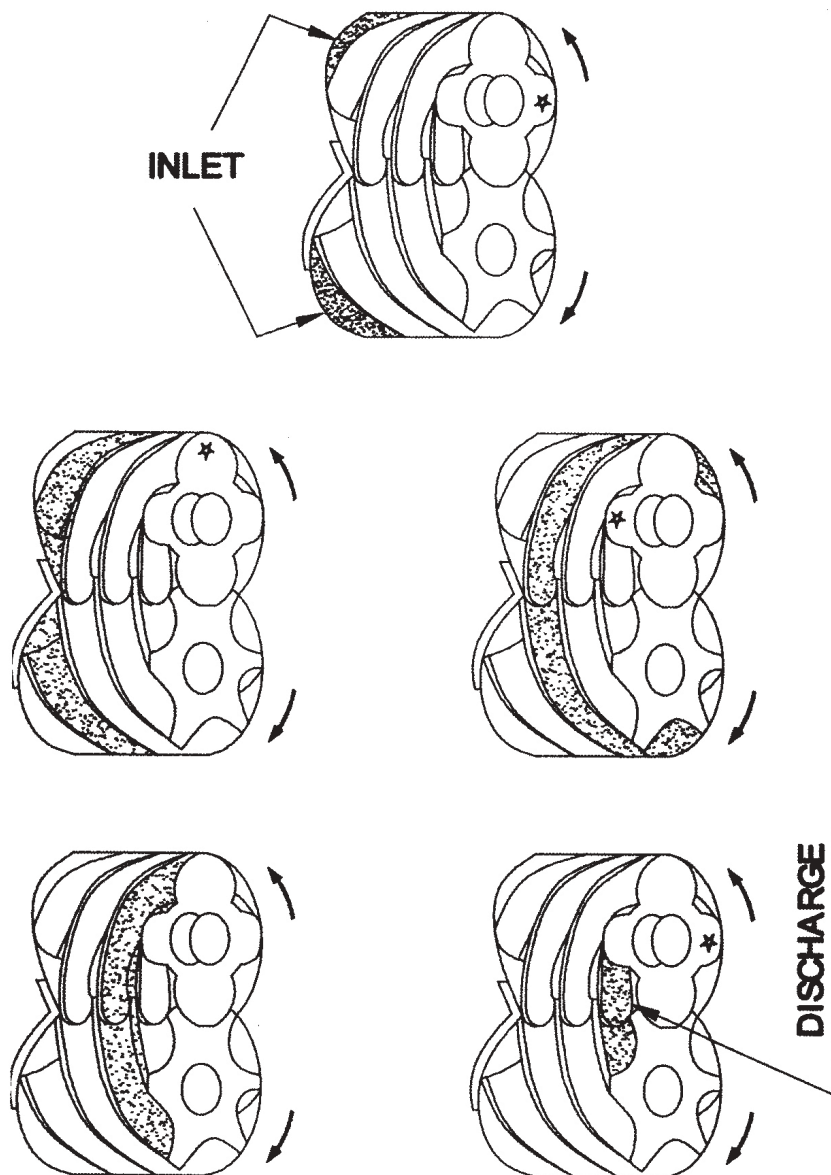

**WORKING PRINCIPLE OF SCREW AIR COMPRESSOR**

## Working Principle

- Compression of air is achieved in a rotary screw compressor in the following manner. Air is admitted at one end of the rotors, where the matching lobe and flute first mesh as the rotors turn. Continued rotation brings the line of meshing past the air inlet port, and then the air in the flute of the female rotor is confined by the lobe of the male rotor and stator. Compression now occurs as the rotors turn further. The far end of the compression pocket turns towards the discharge port and air flows out in the system, as shown in the accompanying figure, which depicts one lobe meshing with one flute.
- The flutes of the female rotor and the lobes of the male rotor correspond, respectively, to the cylinder and piston of a reciprocating compressor. Lubricating oil is injected into the compressor unit (here referred to as the airend), which mixes directly with the air in large quantities as the rotors turn, compressing the air.
- The lubricating oil has four functions.
  - a) As a coolant it takes away the heat of compression.
  - b) It seals the leakage paths between the rotors and housing.
  - c) It acts as a lubricating film between the rotors, allowing one rotor to drive the other directly without a metal-to-metal contact.
  - d) It also lubricates the bearings and gears.

## System Operation

- The air aspirated through the air filter is compressed in the screw compressor driven by the diesel engine. The air drawn into the compressor is throttled by the butterfly valve.
- The air–oil mixture is delivered to the receiver tank through the discharge check valve which acts like a non-return valve.
- The oil and air are separated by the OSBIC process, which utilizes an impact and the difference in density between air and oil to separate them.
- The separated oil is cooled in the oil cooler and is returned to the injection point through the oil filter. This oil circulation circuit, operated solely by a pressure differential, does not require a separate oil pump.
- A final separation is done using a high-efficiency separator, maintaining oil carry-over levels consistently below 10 ppm.
- The thermal valve provided in the oil circuit ensures the desired discharge temperature for optimum performance.
- Oil collected in the receiver tank is cooled by the oil cooler and returned back to the airend through the main oil filter and oil stop valve.
- Compressed air liberated from the air–oil separator element is delivered to the service line through the minimum pressure valve.
- The minimum pressure valve positioned downstream of the oil separator maintains a minimum pressure for supply of oil to the compressor unit for safety.
- The engine is throttled by the actuator, which in turn gets the input air from the receiver tank through the pressure regulator and moisture separator.
- Refer to the schematic diagram provided for various elements used in the system.

## **Functions of various systems**

---

## Functions of various systems

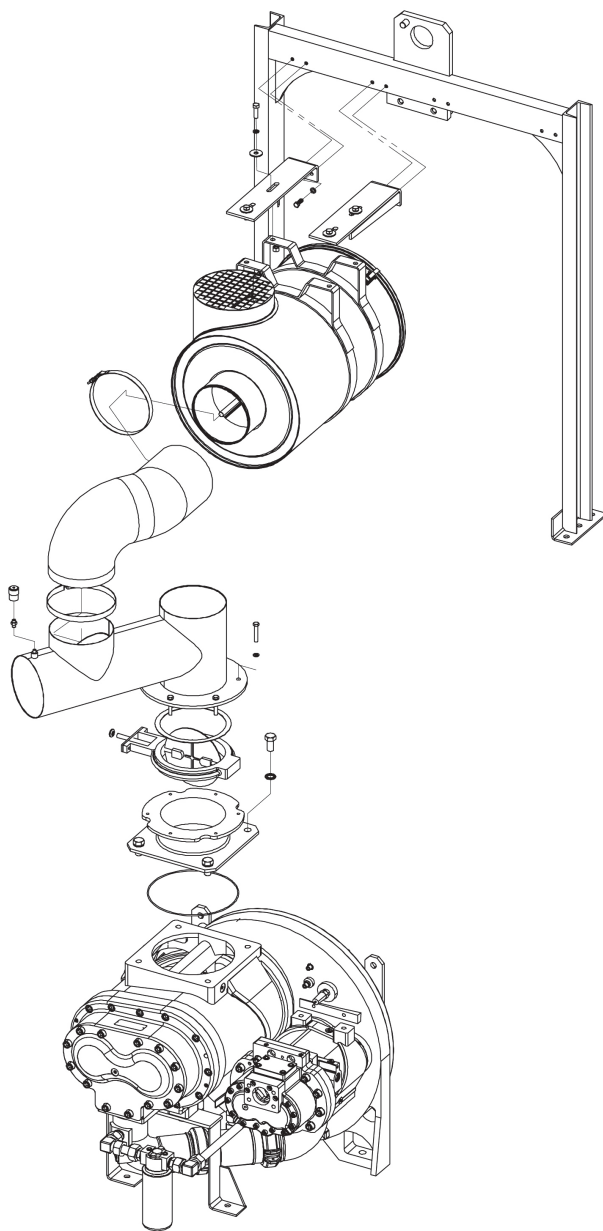

**AIR INLET SYSTEM**

## Functions of various systems

### Air Inlet System

- The air inlet system comprises a dry-type filter, which filters the inlet air and prevents foreign particles from entering the airend.
- The air inlet valve is of the butterfly type and directly controls the amount of air entering the airend. The opening or closing of the valve disc controls the port area in response to the function of a single-acting spring-loaded actuator which operates in coordination with the control system. The actuator receives operating pulses from the pressure regulator valve.
- Replace air filter elements when the restriction indicator is red, or every 1000 hours, whichever is earlier.

# Functions of various systems

## BLOCK DIAGRAM OF DISCHARGE SYSTEM

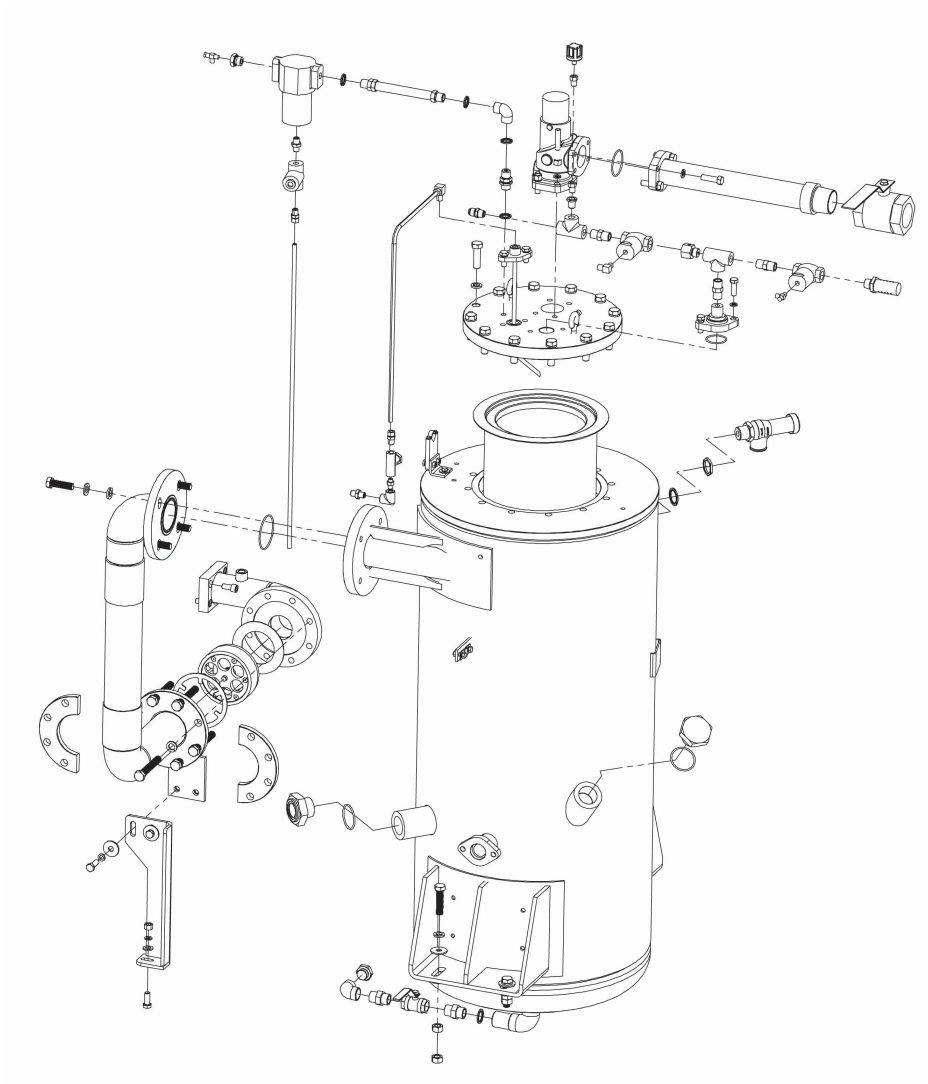
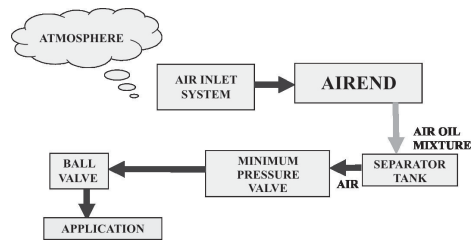

**DISCHARGE SYSTEM**

## Functions of various systems

### Discharge System

- The screw air compressor discharges a compressed air-oil mixture through a discharge check valve into the receiver tank.
- The discharge check valve prevents the compressed air from returning to the compression chamber after the unit is shut down.
- The compressed air-oil mixture enters the receiver tank tangentially. Heavier particles are separated and fall to the bottom of the receiver tank. The separator element at the final stage of air-oil separation is the vital element for getting clean air at the outlet. The separated oil collects on the element surface and descends to the bottom of the separator.
- The return valve (or scavenge line) leads from the bottom of the separator element to the inlet regime of the compressor unit, ensuring that the separated oil is returned to the compressor by the pressure differential between the area surrounding the separator element and the compressor inlet. The nylon tube used in the return line usually checks the oil flow.
- The minimum pressure valve at the outlet of the receiver tank ensures a minimum receiver pressure of 10 kgf/cm<sup>2</sup> during all conditions for proper air-oil separation and proper oil circulation to the aircend.
- A pressure relief valve (located on the wet side of the separator) is set to open if the receiver tank pressure exceeds by this formulae (Working pressure in bar +1) x 1.1
- Oil is to be filled in the receiver tank through the elbow welded on the tank after removing the plug. An oil sight glass enables the operator to visually monitor the receiver tank oil level.



Do not remove caps, plugs or other components when the compressor is running or pressurized. Stop the compressor and relieve all internal pressure before doing so.

# Functions of various systems

## BLOCK DIAGRAM OF COOLING & LUBRICATION SYSTEM

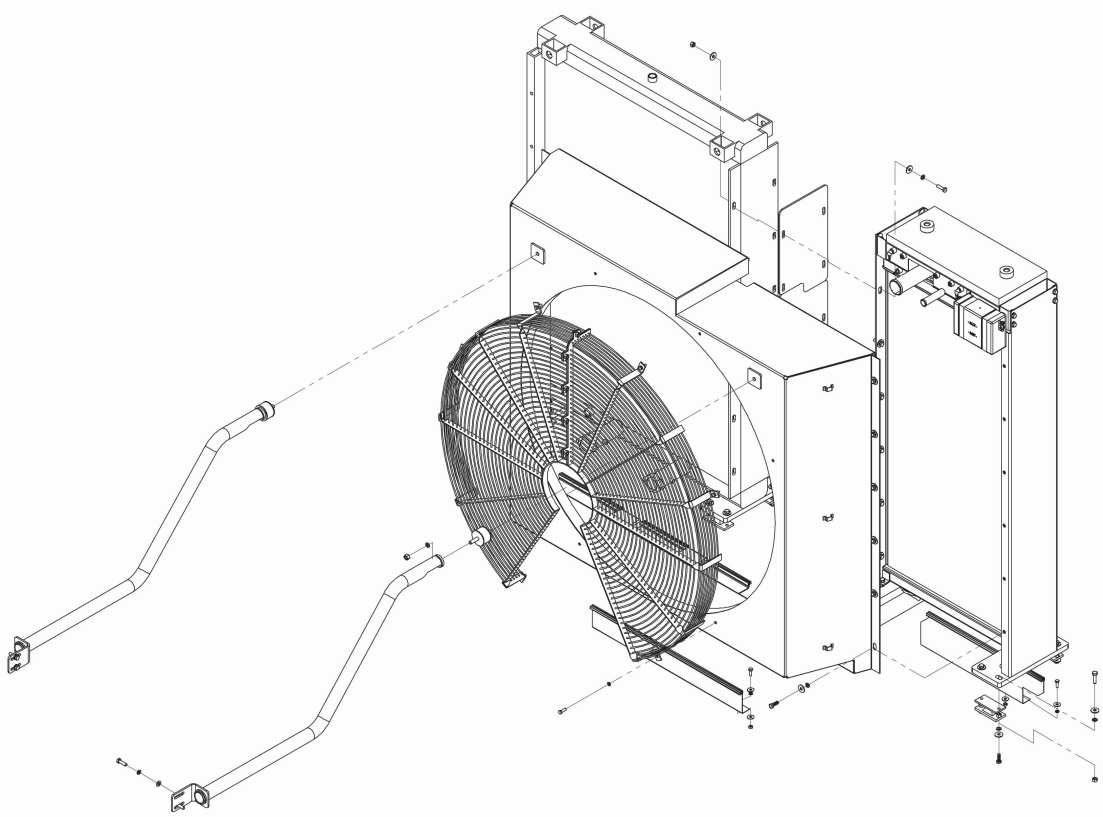
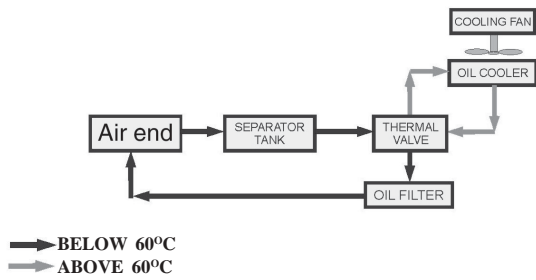

**COOLING SYSTEM**

## Functions of various systems

### Cooling and Lubrication System

- The cooling and lubrication system consists of the fan, shroud, oil cooler, oil filter and thermal valve.
- The pressure in the receiver/sump causes a fluid flow from the sump to the airend through the oil cooler, thermal valve and oil filter.
- The thermal valve is fully closed when the oil temperature is 185°F. **REFER TO THE PARTS LIST FOR THE TYPE OF THERMAL VALVE USED ON A PARTICULAR MODEL.**
- As the discharge temperature rises above 185°F due to the heat of compression, the oil temperature rises and the thermal valve begins to close the oil line from the tank to the airend through the oil filter to divert the oil through the oil cooler. Depending on the oil temperature, the thermal valve opening position ensures that the temperature of the oil at the inlet of the airend is maintained by
  - a) fully allowing the oil from the tank to the airend;
  - b) fully allowing oil from the cooler to the airend; and
  - c) mixing oil from the tank with oil the cooler before it goes to the airend.
- When the machine is started the oil temperature and pressure are low. The oil separated from the air–oil mixture in the receiver tank flows through the return line (scavenge line) to the airend.
- This continues till the required pressure is built up in the receiver tank. As the compressor continues to operate, the temperature of the oil also rises.
- Once the intended pressure is built up in the receiver tank, oil starts to flow to the main line by the pressure differential through the oil cooler, main oil filter, bearing oil filter and oil stop valve to the airend in large quantities, that is, from the high-pressure region in the receiver tank to the low-pressure region in the airend. The return line is operated throughout the whole process.

## Functions of various systems

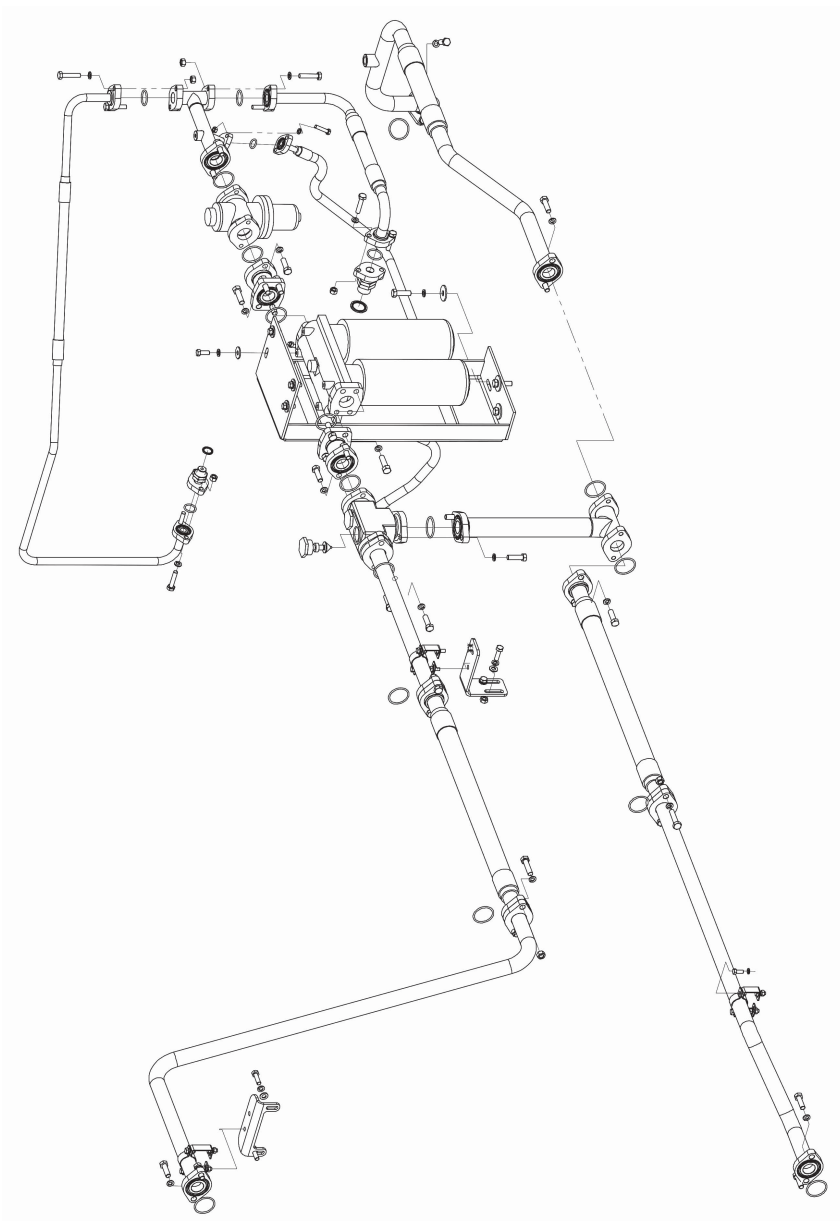

**LUBRICATION SYSTEM**

## Functions of Various Systems

- The oil cooler is so arranged that the lubricating and cooling oil flowing internally through the core section is cooled by the air stream from the cooling fan flowing past the core section. When dirt accumulates on the external surface of the oil cooler, its efficiency is improved. It is recommended that the oil cooler be cleaned every month by directing compressed air through the core of the oil cooler.
- After being cooled the oil is filtered in preparation for injection into the compression chamber and bearings of the compressor unit. The filter has a replaceable element and a built-in bypass valve which allows the oil to flow even when the filter element becomes clogged, requiring a change of the filter element, or when the viscosity of the oil is too high for an adequate flow.
- After the oil is properly filtered, it flows through the oil stop valve to the compressor unit, where it cools the seals and the compression chamber and lubricates the bearings and gears.
- The oil stop valve functions when the unit is shut down. It shuts off the oil supply to the airend. The oil stop valve is held open by a pressure signal from the airend when the compressor runs. When it shuts down, the pressure signal is lost and the oil stop valve closes, isolating the airend from the cooling system.
- A portion of the oil flowing to the airend is routed to a bearing oil filter. All the oil flowing to the gears, the shaft seal and the internal bearings of the compressor unit flows through this extra-fine filter, ensuring that the cleanest possible oil is supplied to these components. This filter also has a built-in bypass valve and a replaceable element.

## Functions of Various Systems

### PG 1200S-Combo 350 TWO-STAGE CONTROL SYSTEM

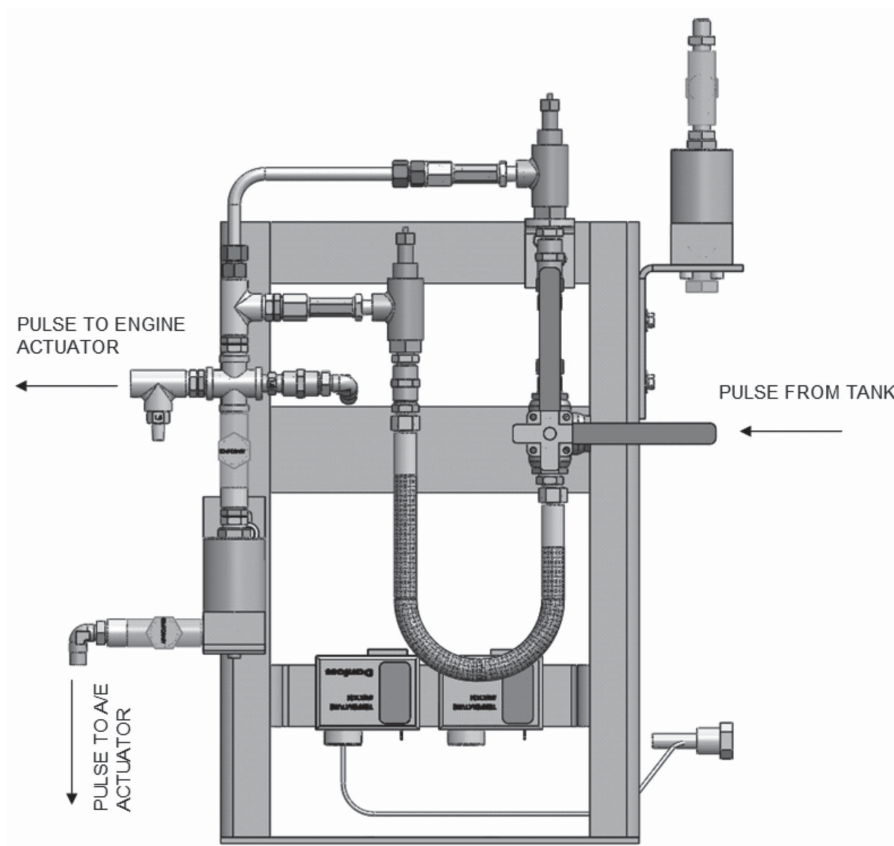

**NOTE :** "The image and explanation is shown for PG1200S-Combo 350 model. The operating pressure will vary and the combo routing will be applicapable / not applicapable as per the model in consideration."

## Functions of Various Systems

### Capacity Control System

- Check the engine oil level, radiator water level, compressor oil level Before starting.
- Close the service line ball valve fully.
- Keep the ball valve in START MODE position
- Switch on the toggle switch. The green bulb (indicates that the machine is ready to start)
- Turn the ignition switch to ignition position
- Wait for 10Secs till the Starter Protection unit ignition indicator lamp glows off
- Hold the ignition switch in override position
- Simultaneously press the start push-button (the self-starter button).
- As soon as the engine builds up speed (press the start push-button for only 5 seconds), release the start push-button.
- Hold the ignition switch key up to the sump pressure raises until it reaches 7 bar & above.
- Now release the ignition override switch.
- When the compressor is started, atmospheric air is drawn through the butterfly valve, compressed and discharged to the air-oil receiver. The pressure builds up in the receiver tank from 0 to 217 Psi.
- After verifying for leakage in the compressor in start mode, keep the ball valve in LOADING MODE to run the compressor for drilling

### Operating Condition :

- Observe the drilling speed
- If drilling speed observes < 1650 RPM, continue to operate as it is condition, which compressor will run in 350 pressure rating.
- If drilling speed observes > 1650 RPM, keep the MODE SELECT in 325 psi mode, which compressor will run in 325 pressure rating.
- With the 325 Psi pressure rating, once the drilling speed reaches 1500 RPM, Keep the MODE SELECT in 350 psi mode, which compressor will run in 350 pressure rating.

### Pressure Setting (If required while commissioning) :

- Observe the drilling speed
- Start the compressor without master
- Set the pressure rating (HP) as 350 Psi @ 1600 RPM by adjusting the HP Psi pressure regulator
- Set the pressure rating (LP) as 325 Psi @ 1600 RPM by adjusting the LP pressure regulator

NOTE : For immediate starting of compressor MCB should not be switched off

## Functions of Various Systems

### Engine actuator setting

**Water yield speed setting :**

Adjust the nut to position the plunger appropriately to set the water yield speed

**Idle speed setting :**

Adjust the slider to set the idle speed in the slot

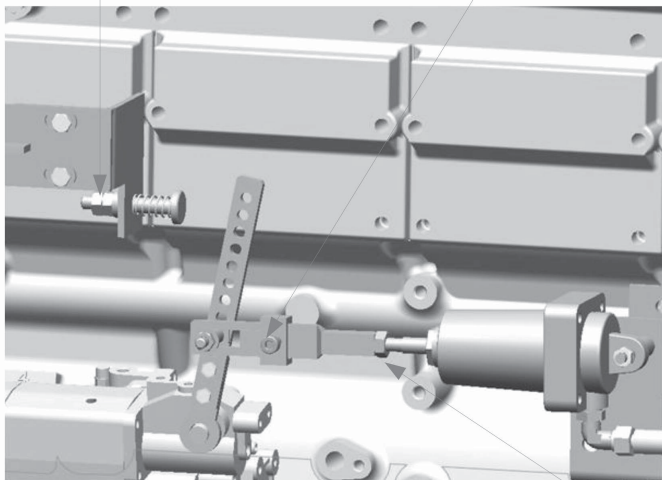

**Flushing speed setting:**

Adjust the lever to set the flushing speed

## Functions of Various Systems

### Base System

The structure of the compressor is made of formed channels adequately designed with cross-beams and dimensioned to withstand the basic weight, forces acting during the running of the compressor and forces acting during towing. The leaf springs, axles and wheels are designed and selected to withstand static and dynamic loads. Refer to the figure given below to understand the parts of the base system. Refer to the parts manual for the part numbers.

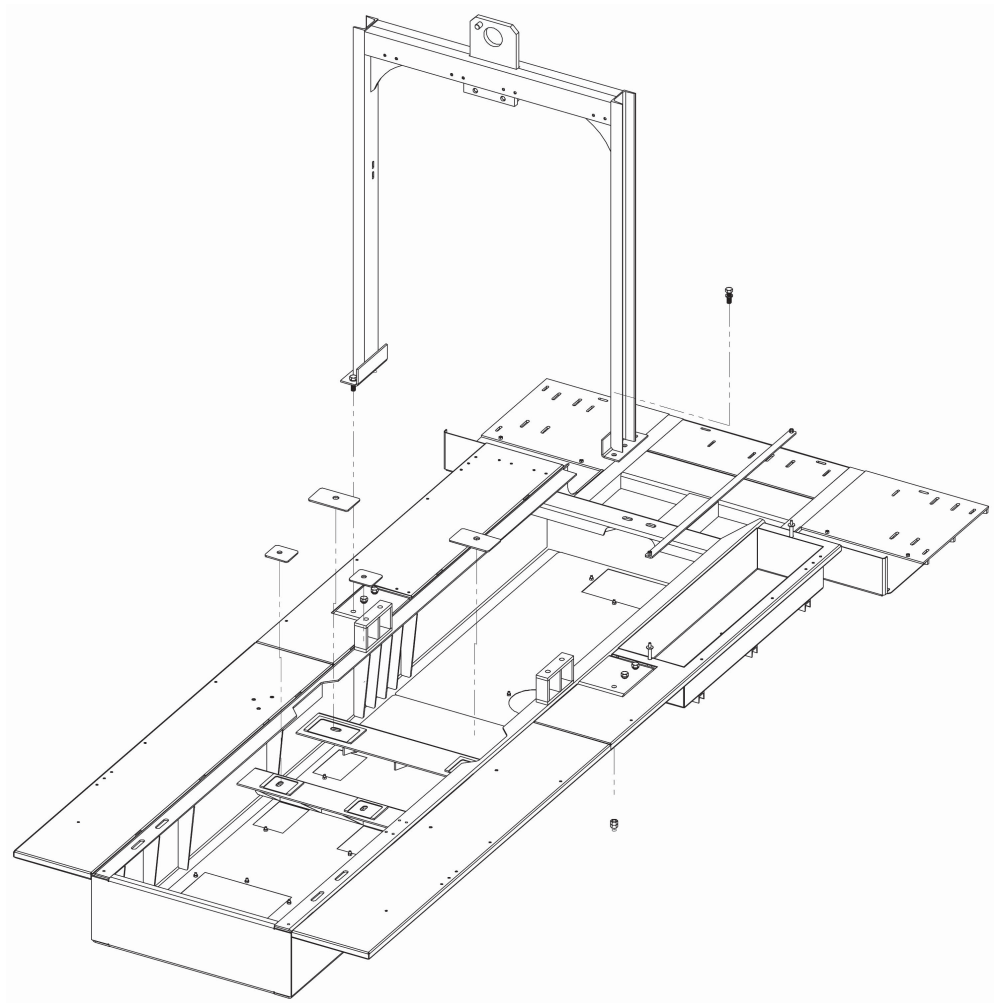

**BASE SYSTEM**

## Functions of Various Systems

### Canopy System

The canopy assembly is made of multiple panels for ease of manufacturing and assembly/disassembly. The canopy design ensures that there is an adequate flow of air into it and hot air flows out without any restriction when the compressor is run with all the doors closed. Refer to the figure given below to understand the various parts of the canopy. Refer to the parts manual for the part numbers.

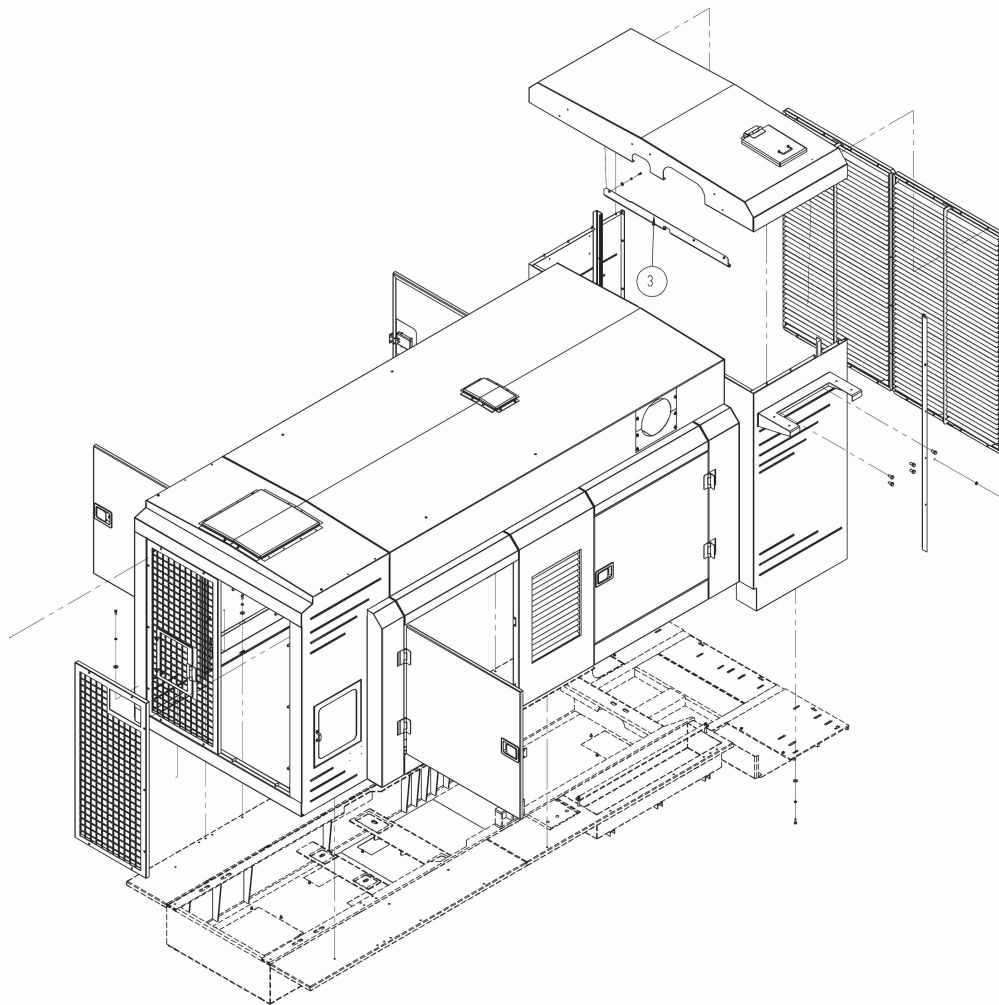

**CANOPY SYSTEM**

## Functions of Various Systems

### Engine System

The diesel-powered engine supplied is rated for continuous duty application at full load. The engine, with all accessories, will run trouble-free provided the periodic maintenance is done as per the recommendations given in the engine manual. The diesel tanks mounted on the base frame are of adequate capacity to run the compressor at full load for 8 hours.

For regular maintenance and inspection of the engine, contact the nearest Cummins dealer.

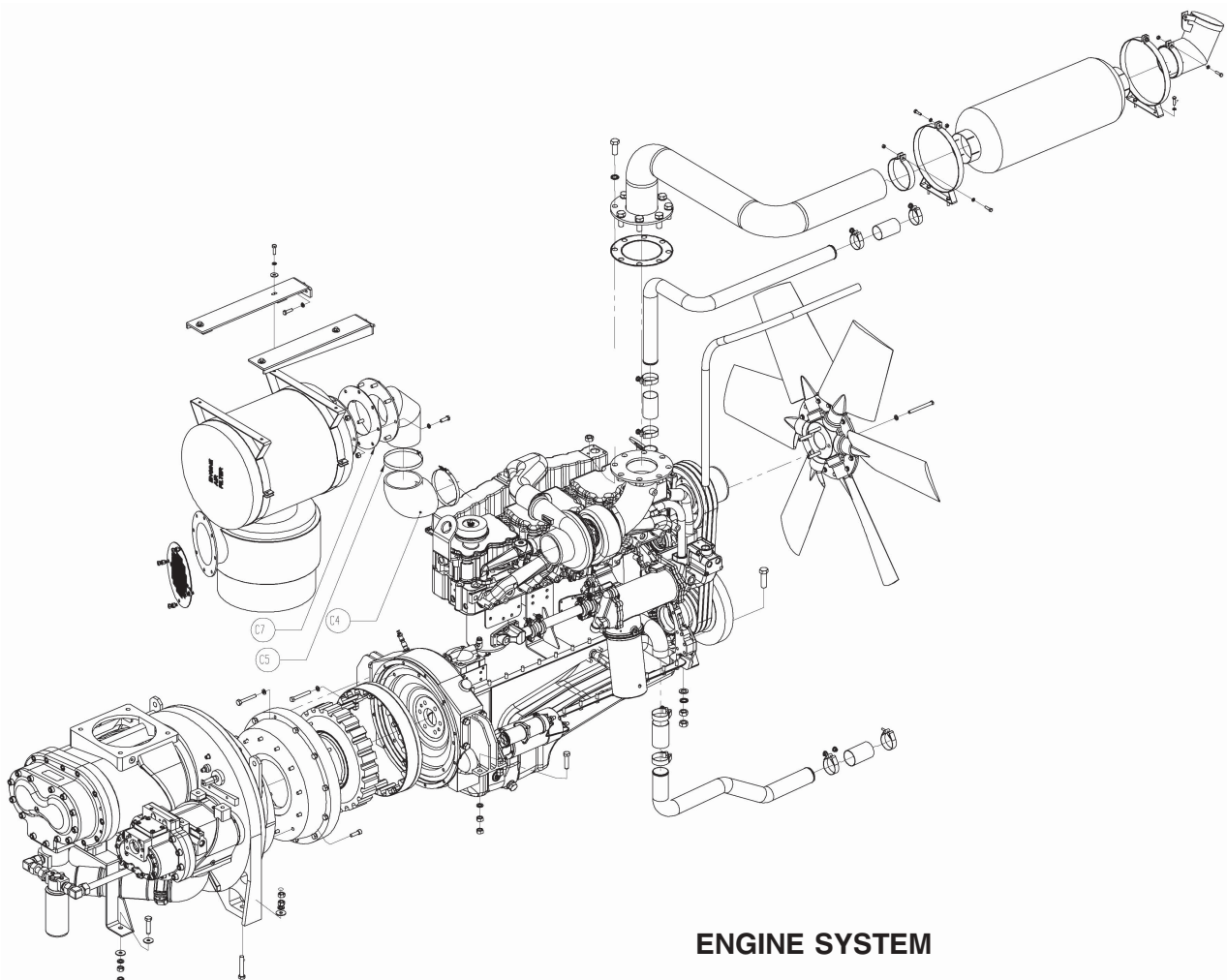

## Functions of Various Systems

### Lubrication Oil

Oil performs a very critical function in an oil-flooded screw-type air compressor. This takes away the major part of the heat of compression, seals all the areas and lubricates the bearings and gears. The important criteria of a lubricant for a screw compressor are its

- viscosity
- wear characteristics
- demulsibility
- heat resistance
- thermal stability

Elgi Air Lube is blended using heavy-duty hydraulic-based oils with appropriate amounts of additives to ensure satisfactory compressor performance.

The life of a synthetic oil is determined by the operating temperature. For every 10°C above 120°C, the life of the oil goes down by almost 30–40%. It is recommended that the oil change frequency be varied in the summer months and winter months to get the best out of the synthetic oil and the compressor. A good record of the operating temperature of the compressor is essential to do this. Continuous operation of the compressor at high temperatures beyond 120°C without changing the oil will lead to varnish formation and will affect the life of the bearings and air end. **If the compressor is kept idle for a long period, the oil may deteriorate, depending on the storing conditions. Please consult local elgi dealer for details..**

The oil must be changed:

- **once in 500 hours if mineral oil is used**
- once every 2000 hours when a semi-synthetic oil is used
- once in 4000 hours in the case of a synthetic oil

## Lubrication oil

RECOMMENDED ELGI OIL			
Elgi Oil Grade	Oil Change Frequency	Elgi Part number	Contained Volume
AIRLUBE	500 hours	000998043	210 Litres
AIRLUBE PLUS	1000 hours*	00099805A	20 litres
		00099805B	50 litres
		00099805C	210 litres

\* For operating temperature above 90°C and dusty atmospheric conditions, recommended oil change frequency is 800 hours.

- All the above figures are guide lines based on extensive trials in the field. However our service engineers can help you to optimise the oil drain interval for your application based on the operating temperature, pressure and the environment condition.
- **The Discharge Temperature Switch** is fitted on the panel. It shuts down the compressor if the discharge air-oil mixture temperature reaches the preset value of  $120 \pm 5^{\circ}\text{C}$ . The probe is fitted on the airend outlet cover or receiver tank.

## Safety and Interlocking Devices

The following safety and interlocking devices have been provided in your Elgi portable rotary screw air compressor for safe and reliable service.

### Safety Devices

The Pressure Relief Valve is located on the wet side of the oil separator of the receiver valve tank and is set to open if the tank pressure exceeds the working pressure by 45 psi.

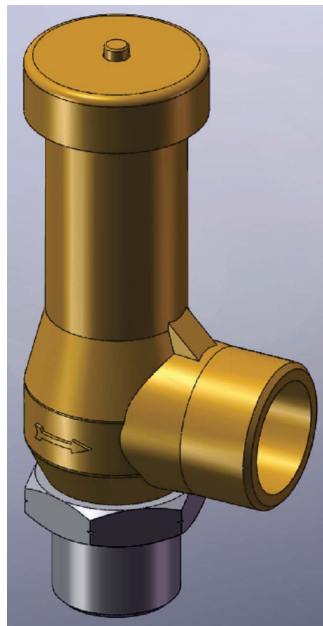

**PRESSURE RELIEF VALVE**

## Safety and Interlocking Devices

- **The Discharge Temperature Switch** is fitted on the panel. It shuts down the compressor if the discharge air-oil mixture temperature reaches the preset value of  $120 \pm 5^{\circ}\text{C}$ . The probe is fitted on the airend outlet cover or receiver tank.
- **The High Pressure Switch** Line is fitted on the sump. When the sump pressure exceeds the working pressure (working pressure+3 bar) this switch trips the unit automatically.
- **The Low Pressure Switch** is fitted after oil stop valve in the lubrication manifold. While operating the unit, the compressor sump should be maintained at a minimum of 7 bar. Otherwise the unit trips off automatically.
- **The Inter-stage Temperature Switch** is fitted at the outlet of the first-stage airend. It trips the unit when the discharge oil temperature reaches  $120 \pm 5^{\circ}\text{C}$

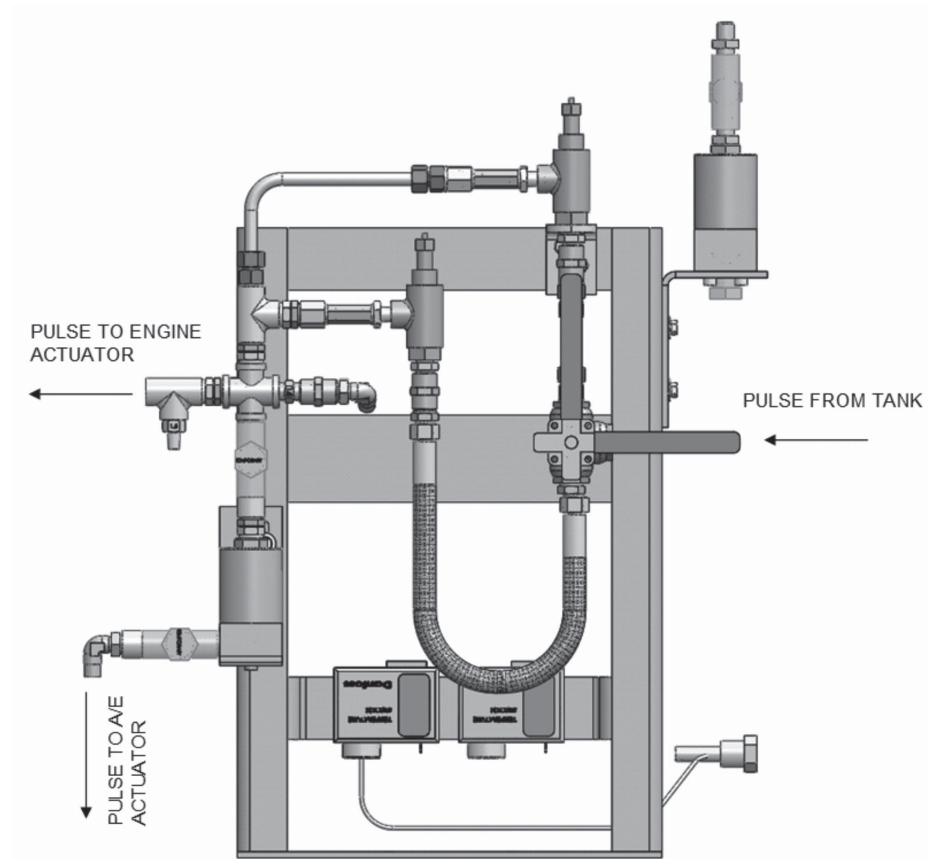

## Safety and Interlocking Devices

The **Engine Water Temperature Switch** indicates the radiator water temperature and trips the unit when the water temperature reaches 98°C.

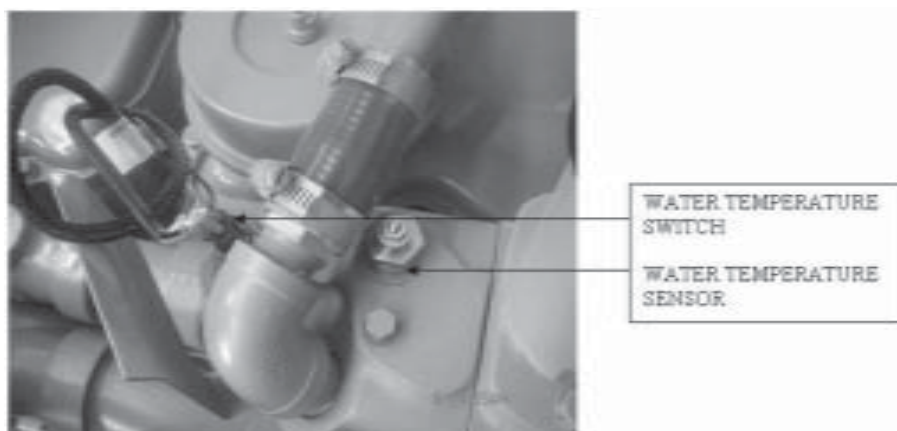

The **Engine Low Lube Oil Pressure Switch** is set at 3 bar. When the engine oil sump pressure drops below 3 bar the unit trips automatically.

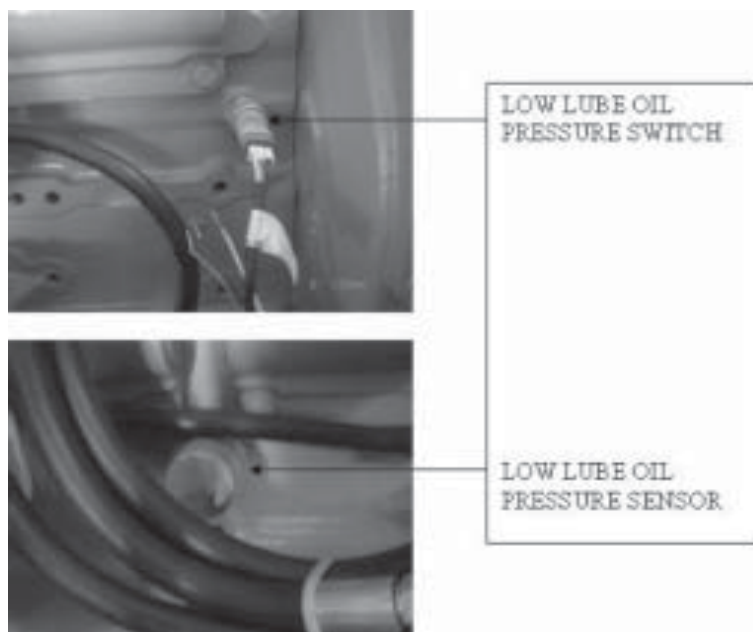

## Safety and Interlocking Devices

The **Oil Level Indicator** of the compressor is fitted at the compressor sump (separator tank). This indicates the oil level in the sump before the unit is started. When the machine is running, the oil level may not be readable.

The **Line Pressure Gauge** reading is taken from the dry air from the sump top plate. This indicates the line pressure in all operation modes.

The **Sump Pressure Gauge** reading is taken from the wet side of the sump. This indicates the sump pressure in all operation modes.

The **Ammeter** fitted in the panel shows the condition of the battery.

The **Discharge Temperature Gauge** reading is taken from the discharge line (the line from the second-stage outlet to the sump). The maximum allowable temperature of the discharge air-oil mixture is 120°C in the case of a mineral oil. This gauge indicates the overall system temperature.

The **mcb** is fitted on the panel for safety.

The **Air Filter Indicator** for the compressor and engine is fitted at the point of entry of air to the filter assembly. This indicates the condition of the air filter. When the air filter is choked the red-coloured stem moves forward and provides an indication that cleaning is required. This also provides an idea of the restriction level of the air filter element so that maintenance can be carried out accordingly (either replacement or cleaning).

The **Engine Oil Pressure Gauge** is fitted at the engine oil sump block to indicate the oil pressure inside the sump.

The **Engine Water Temperature Gauge** indicates the temperature of the water cooling the engine.

The **Hour Meter** measures the running hours of the engine.

The **Manifold Pressure Gauge** of the airend is fitted at the oil line manifold (near the bearing oil filter line) to indicate the pressure of the oil going to the bearings of both airends.

## Safety and Interlocking Devices

### Interlocking Devices

The following interlocking devices have been provided your compressor for safe and reliable service.

The **Minimum Pressure Valve** is fitted at the outlet of the oil separator. It maintains a minimum receiver tank pressure of about 10 kgf/cm<sup>2</sup> during all conditions, which facilitates proper air-oil separation and circulation of oil to the aircend.

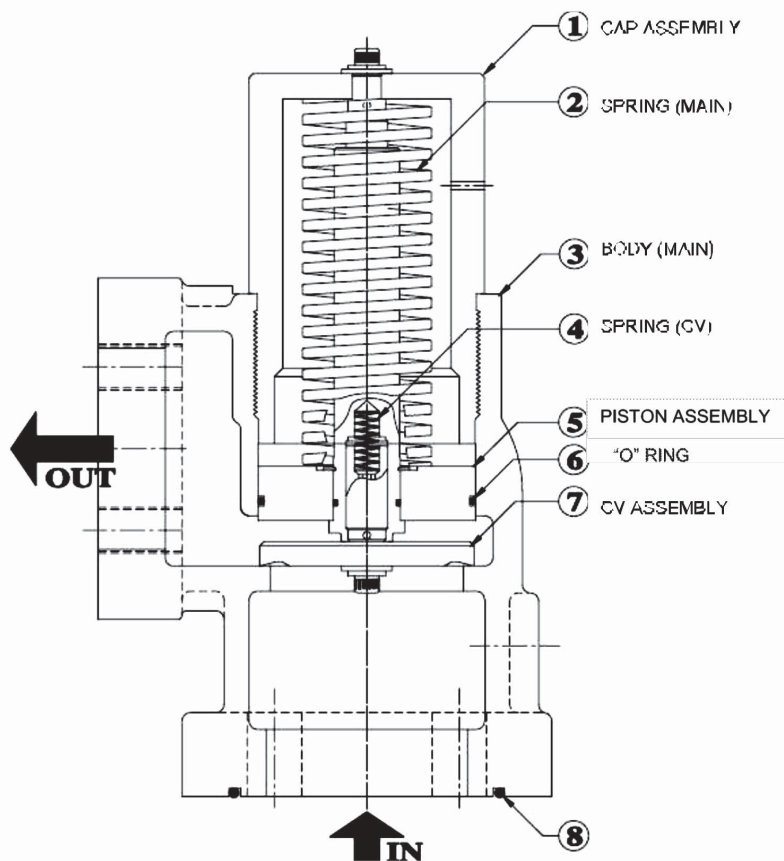

**MINIMUM PRESSURE VALVE**

## Safety and Interlocking Devices

The **Oil Stop Valve** is located downstream of the bearing oil filter and upstream of the airend. It cuts off the oil supply to the compressor unit when the unit is shut down.

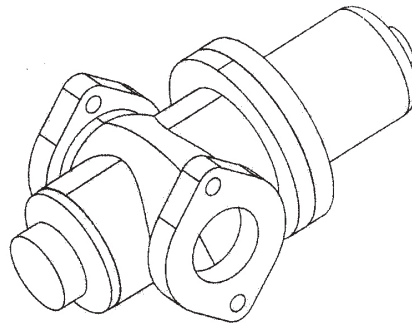

**OIL STOP VALVE**

The **Pressure Regulator Valve** can be adjusted depending upon your pressure requirements. It is set to supply a pressurized air pulse to the single-acting actuator, which in turn operates the butterfly valve to gradually open or close the inlet port of the airend, in accordance with the outlet air pressure at suction.

It also operates the engine governor lever to vary the speed between 1200 rpm (idle) and 1800 rpm, or the rated speed, according to the air demand.

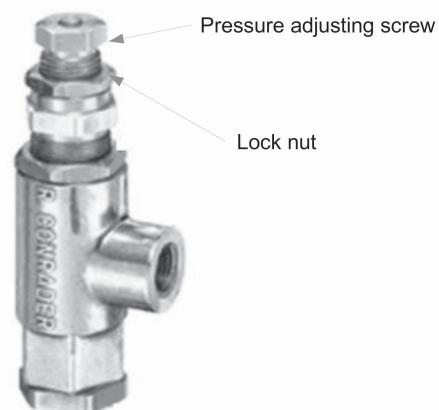

**PRESSURE REGULATOR VALVE**

## Safety and Interlocking Devices

An **actuator** connected to the butterfly valve opens the butterfly valve or closes it gradually in response to the pressure signal received from the pressure regulator valve, thereby controlling the amount of intake air of the air end.

It also operates the engine governor lever to increase/decrease the engine speed according to the demand.

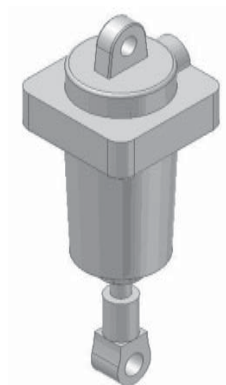

**ACTUATOR**

The **Blow Down Valve** installed in the receiver tank serves two functions:

When the compressor starts up, the air pulse line from the second-stage outlet opens, which in turn closes the blow down valve to permit the air-oil pressure to build up in the air-oil receiver tank.

When the machine is shutting down, the air pulse line from the second-stage outlet closes, which in turn opens the valve to bring the tank pressure down to atmospheric.



**BLOW DOWN VALVE**

## Safety and Interlocking Devices

The **Discharge Check Valve** is used for automatically limiting the flow in a piping system to a single direction. This (non-return) valve is installed between the second-stage outlet and the separator tank inlet point to allow the air-oil to flow in one direction alone so that the air filter is protected from a sudden reverse flow of the air-oil mixture from the receiver tank when the unit trips.

When the machine is running, the air-oil mixture moves from the second-stage air end outlet to the air-oil receiver tank.

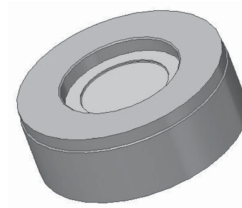

**DISCHARGE CHECK VALVE**

The Thermal Valve allows the oil to flow from the receiver tank to the oil filter when the temperature is less than or equal to the "start to move temperature". It also bypasses the oil to the oil cooler when the temperature is above the "cracking temperature". This maintains the dew point temperature of the whole cooling system.

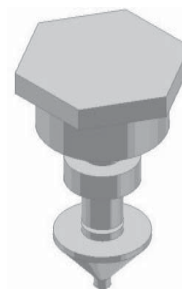

**THERMAL VALVE**

## Electrical System and Control Elements

### System Components and Description

The electrical system comprises not only the equipment necessary to operate the compressor but also a system included to shut down the machine in the event of a malfunction. The components of the electrical system are an engine starter with an integral solenoid, batteries (one or two as the case may be) and an alternator with a built-in voltage regulator.

The electrical control system consists of the following:

- 24 V battery
- Ammeter
- Alternator with built-in voltage regulator
- Ignition/override switch
- Engine stop knob
- Start push-button
- Engine starter with integral solenoid
- Hour meter
- Indicating lamps

## Electrical System and Control Elements

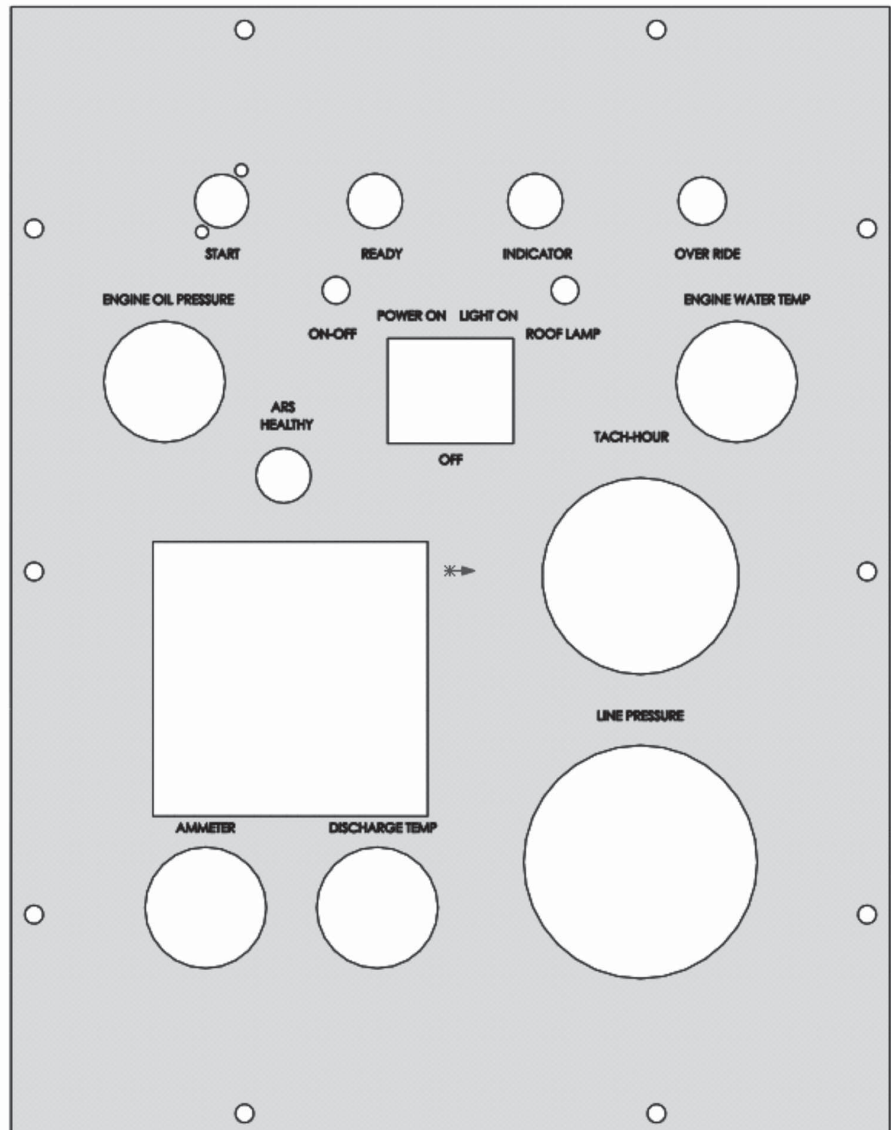

## Electrical System and Control Elements

### Instrument Panel

The instrument panel consists of a line pressure gauge, discharge temperature gauge, engine oil temperature gauge, engine water temperature gauge, engine oil pressure gauge, ammeter, start button, override key, engine stop knob, tach-hour meter and indicating lamp. The functional locations of the following controls are as follows.

- **Start Button:** Press button to start the engine. Release immediately when engine fires.
- **Indicator Lamp:** Glows when alternator is not charging.
- **Ready Lamp:** Glows when circuit connections are correct.
- **Override Key:** Turn key to check all electrical connection. Turn further to override all switches.

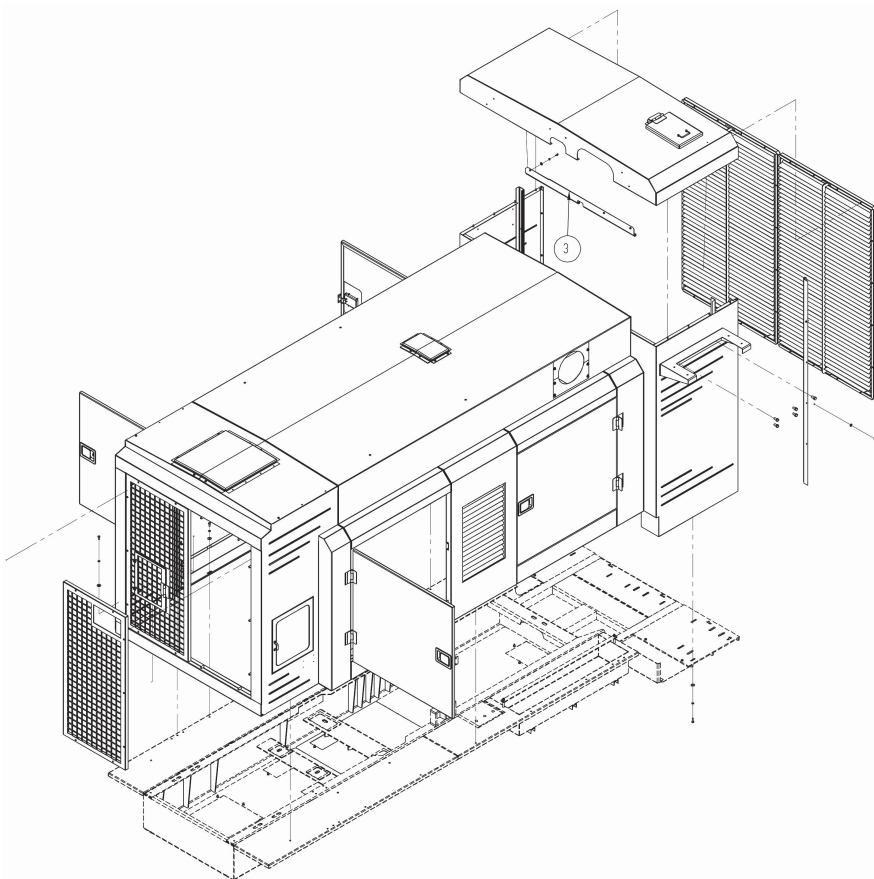

## Electrical System and Control Elements

- The **ammeter** indicates the performance of the electrical charging system. Upon starting the engine, the needle should move to the positive (+) side of zero (0); however the needle should fall back to a position slightly past the zero on the plus side after the engine starts. The ammeter should never indicate a reading on the negative (-) side of zero as this indicates that the alternator is not charging.
- The **engine water temperature gauge** monitors the temperature of the cooling water.
- The **engine oil pressure gauge** monitors engine lube oil pressure.
- The **engine oil temperature gauge** monitors the temperature of the engine oil inside the crankcase.
- The **line pressure gauge** is connected to the dry side of the receiver tank and continually monitors the service line air pressure.
- The **tach-hour meter** indicates the engine speed as well as the accumulated hours of compressor operation. This is useful for planning and logging service operation.
- The **discharge temperature gauge** monitors the temperature of the air and oil leaving the airoend.
- The **sump pressure gauge** is connected to the wet side of the receiver tank and continually monitors the sump air-oil pressure.
- The **fuel level gauge** is connected to the diesel tank and monitors the level of fuel in the tank in trolley units.

## Electrical System and Control Elements

### Purpose of Controls

NO.	CONTROL OR INDICATOR	PURPOSE
01.	Start push-button	Press to start the engine. Release immediately when engine fires.
02.	Toggle switch	Put it in OFF position to stop the engine.
03.	Over ride switch key	Turn key to check all electrical connections. Turn further to override all switches. Release the key once engine starts.
04.	Ammeter	Monitors the performance of the engine alternator and is the primary indicator of an electrical malfunction. The normal reading is slightly to the + side of '0'.
05.	Engine oil pressure gauge	Monitors the engine oil pressure. The normal reading is 3-4 kgf/cm <sup>2</sup> at the rated speed.
06.	Engine water temperature gauge	Monitors the temperature of the engine water. Normal operating temperature is 70-90°C.
07.	Engine oil temperature gauge	Monitors engine oil temperature. Normal operating temperature is 75-95°C.
08.	Discharge temperature gauge	Monitors the temperature of the air-oil mixture leaving the compressor unit.
09.	Oil sight glass	Monitors the oil level in the receiver tank. Check oil level only when machine is shut down.
10.	Oil stop valve	Cuts off flow of oil to the compressor unit when the machine is shut down and allows a flow of oil to the unit when starting up.

## Electrical System and Control Elements

11.	Minimum pressure valve	Maintains a minimum pressure of upto 10 kgf/cm <sup>2</sup> in the receiver tank. This valve restricts the air discharge from the receiver tank to the service line when the pressure falls below 10 kgf/cm <sup>2</sup> . However the full flow is allowed at the normal operating pressure.
12.	Single-acting actuator valve	Regulates the amount of air entering the inlet valve.  This regulation is determined by the amount of air being used at the service line.
13.	Pressure regulator valve	Opens a pressure line between the receiver tank and actuator, allowing the actuator to regulate the air delivery according to the air demand.
14.	Pressure relief valve	Opens when the pressure in the tank exceeds the designed value.

# Maintenance

## General

As you read this section, you will see that the maintenance programme of the unit is quite minimal but important. The use of the service indicator provided for the suction filter alerts you when service maintenance is required.

For the maintenance requirements of the engine, refer to the engine manual, which provides detailed service instructions.

## Daily Operation

Before starting the machine, it is necessary to check the oil level in the receiver tank. Should the level be low, add the necessary amount. If the addition of oil becomes too frequent, a problem has developed which is causing this excessive loss. Refer to the troubleshooting section (excessive coolant consumption) for a probable cause and remedy.

After a routine start has been made, observe the instrument gauges and be sure they monitor the correct readings for that particular phase of operation. It is recommended that after the machine has warmed up a general check on the overall machine and instruments be made to ensure that the compressor is running properly.



Do not remove caps, plugs or other components when the compressor is running or pressurized. Stop the compressor and relieve all internal pressure before doing so.

## Maintenance

### **Maintenance Checklist: After 500 Hours of Running**

- Change the main oil filter elements.
- Change the compressor oil.
- Check the tension of the fan belt.
- Check the control system (regulator, actuator, hoses).
- Clean the return line strainer.
- Check the electrical system.
- Check all the gauges.
- Check and clean the radiator and cooler externally.
- Check the condition of the airend bearing using the SPM meter.
- Check and replace the tyre coupling element.
- Check the shaft seal condition for any leakages.

## Maintenance

### **Maintenance Checklist: After 1500 Hours of Running**

- Check and change the main oil filter elements.
- Change the compressor oil.
- Check and change the separator element.
- Check the tension of the fan belt.
- Check the control system (regulator, actuator, hoses).
- Clean the return line strainer.
- Check the electrical systems.
- Check all the gauges.
- Check and clean the radiator and cooler externally.
- Check the condition of the airend bearing using an SPM meter.
- Check and replace the tyre coupling element.
- Check the shaft seal for any leakages and replace if required.
- Check the inlet face of the second-stage rotor (after removing the pipe connecting to the interstage)

### **Maintenance Checklist: After 3000 Hours of Running**

- Check and change the main oil filter elements.
- Change the compressor oil.
- Check and change the separator element.
- Check the tension of the fan belt.
- Check the control system (regulator, actuator, hoses).
- Clean the return line strainer.
- Check the electrical systems
- Check all the gauges.
- Check and clean the radiator and cooler externally.

## Maintenance

- Check the condition of the airend bearing using an SPM meter.
- Check and replace the tyre coupling element.
- Check the shaft seal for any leakages and replace if required.
- Clean the receiver tank thoroughly.

### **Maintenance Checklist: After 5000 Hours of Running**

- Check and change the main oil filter elements.
- Change the compressor oil.
- Check and change the separator element.
- Check the tension of the fan belt.
- Check the control system (regulator, actuator, hoses).
- Clean the return line strainer.
- Check the electrical system.
- Check all gauges.
- Check and clean the radiator and cooler externally.
- Check the condition of the airend bearing using an SPM meter.
- Check and replace the tyre coupling element.
- Clean the receiver tank thoroughly.
- Check the shaft seal for any leakages.
- Check the inlet face of the second-stage rotor (after removing the interstage connecting pipe).
- Change the airend tube line hoses.

#### **NOTE**

The change hours are given as guidelines for normal operating conditions and may vary depending on the site conditions.

# Maintenance

## Components Maintenance and Replacement Procedure

### Oil Filter

The lubrication and cooling system of the compressor is provided with a spin-on filter with an integral bypass valve. It is located between the (air-cooled or water-cooled) oil cooler and the compressor unit. When a new element is installed all the oil flows through the entire area of the element, from outside to inside. As the element becomes contaminated with dirt, the pressure drop across the element increases and the bypass valve opens. Thus the flow of oil through the system continues and prevents any damage from loss of oil. An exploded view of the oil filter is provided in the accompanying figure. This is a full-flow filter with a replaceable pleated element. For servicing this filter, order the repair kit. The procedure for complete servicing of this filter is explained below.

### Disassembly

- Loosen the filter elements and remove the same.

### Reassembly

- Apply a thin film of oil to the gaskets on the new element.
- Tighten the new element on to the filter head, by hand only.

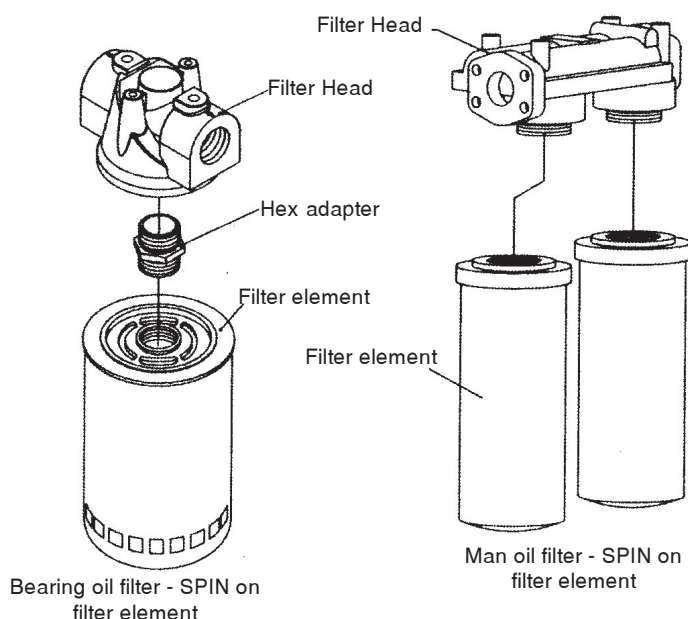

**OIL FILTER—SPIN-ON TYPE**

## Maintenance

### OIL FILTER-CATRIDGE TYPE

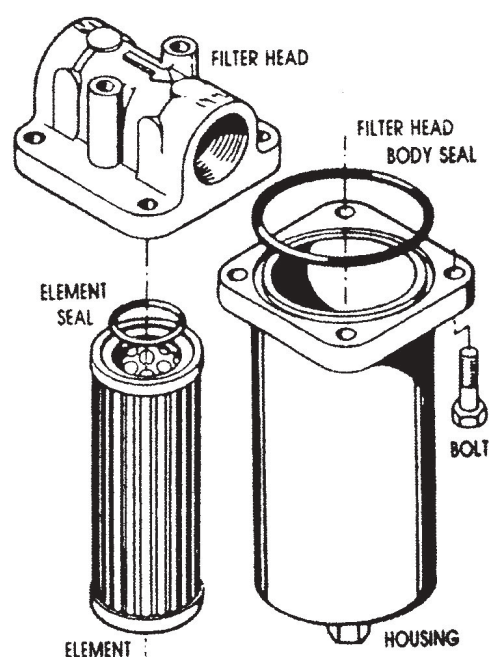

#### Oil Service Procedure

- Drain the old oil from the sump/separator tank.
- Drain the old oil from the oil cooler inlet/outlet points.
- Remove the oil filter elements (main oil filter/bearing oil filter/return line filter).
- Rotate the coupling assembly by rotating the engine fan and remove the oil completely from the separator tank.
- Replace the oil filter elements (main oil filter/bearing oil filter/return line filter).
- Refit all the plugs of the sump, oil cooler and oil filters.
- Use specified quantity of a recommended oil.
- Run the unit for a few minutes and stop the compressor after closing the service ball valve.

## Maintenance

- Recheck the oil level in the sump. It should be at the half mark of the glass after the fumes settle down. If necessary, add oil.
- Change the air filter element after every 1000 hours of running.
- Change the separator element after every 1000 hours of running.
- Clean the radiator and oil cooler using an air jet with a pressure of 4 bar only after every 1000 hours of running.

After 2000 hours of running, in addition to all the above, clean the receiver tank thoroughly. Also check each of the accessories independently to see if it functions and replace the components as necessary.

### **RECOMMENDATION FOR SPIN-ON TYPE OIL FILTER- FITTED UNITS**

- Change the main oil filter element (2 nos.) after every 500 hours of running.
- Change the bearing oil filter element after every 500 hours of running.
- Change the return line filter after every 1000 hours of running.
- Change the air filter element after every 1000 hours of running.
- Change the compressor oil after every 500 hours of running (mineral oil).
- Change the separator element after every 1500 hours of running.

## Maintenance

### **RECOMMENDATION FOR ENGINE CONSUMABLES MAINTENANCE**

- Change the engine oil after every 250 hours of running.
- Change the engine lubrication oil filter kit after every 250 hours of running.
- Change the engine fuel filter after every 250 hours of running.
- Change the engine air filter after every 1000 hours of running.
- Change the corrosion-resistant filter of the engine after every 250 hours of running.
- Change the engine bypass filter after every 250 hours of running.

# Maintenance

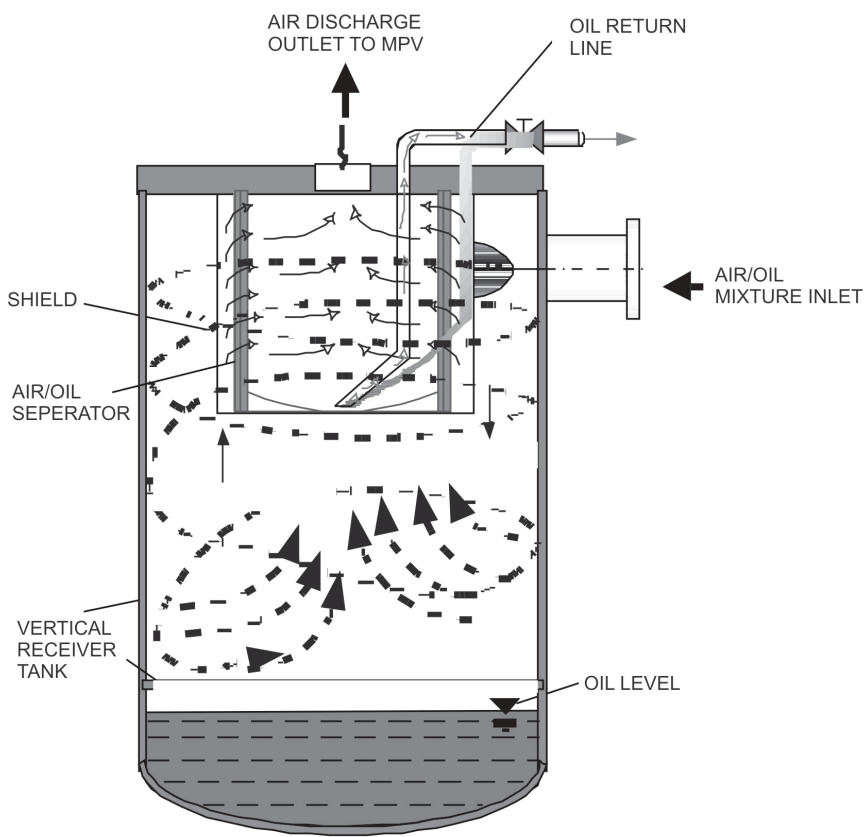

## Maintenance

### Separator Element

The separator element must be changed after every 1500 hours of running. Order the separator element kit. Follow the procedure listed below for separator replacement.

- Relieve the oil pressure from the receiver tank and all fluid lines.
- Disconnect all the piping connected to the receiver tank cover to isolate the receiver tank from return lines, the service line, etc.
- Loosen and remove the hex head bolt from the cover plate.
- Lift the cover plate from the receiver tank.
- Remove the separator element.
- Inspect and clean the receiver tank for rust, dirt, etc.
- Place the new separator element in the receiver tank, taking care not to dent it against the tank opening.
- Clean the bottom of the receiver tank and remove any rust.
- Replace the cover plate and fasten the cover on the receiver tank.
- Reconnect all piping. While doing so, make sure that the return line tubes have a dimensional clearance of  $\frac{1}{4}$ " above the bottom of the separator element. This will ensure that there is a proper oil return flow to the compressor.
- Clean the return oil strainer before restarting the machine.

# Maintenance

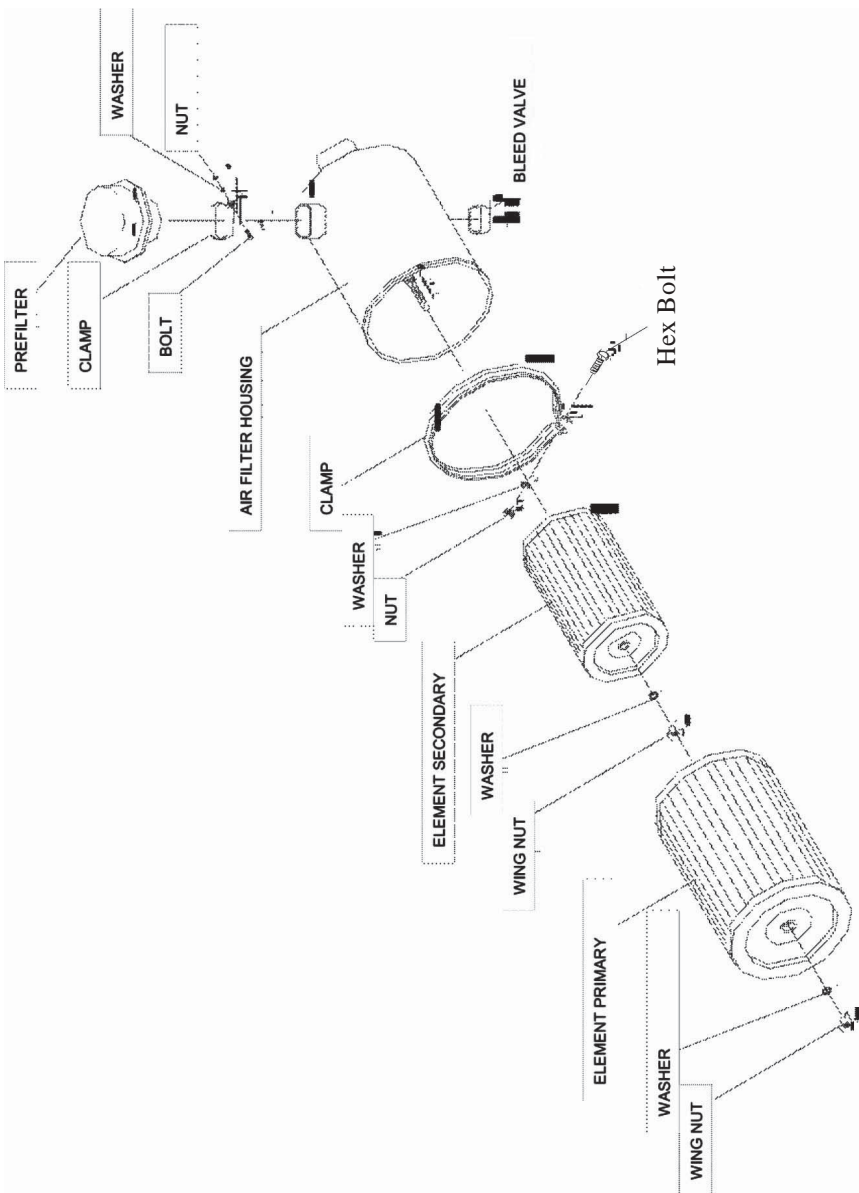

**Air Filter**

## **Maintenance**

### **Air Inlet Filter Cleaning Procedure**

Refer to the accompanying figure for details of the air inlet filter.

When the air filter clog indicator indicates a blocked condition, remove the air filter and replace it with a new air filter.

## Maintenance

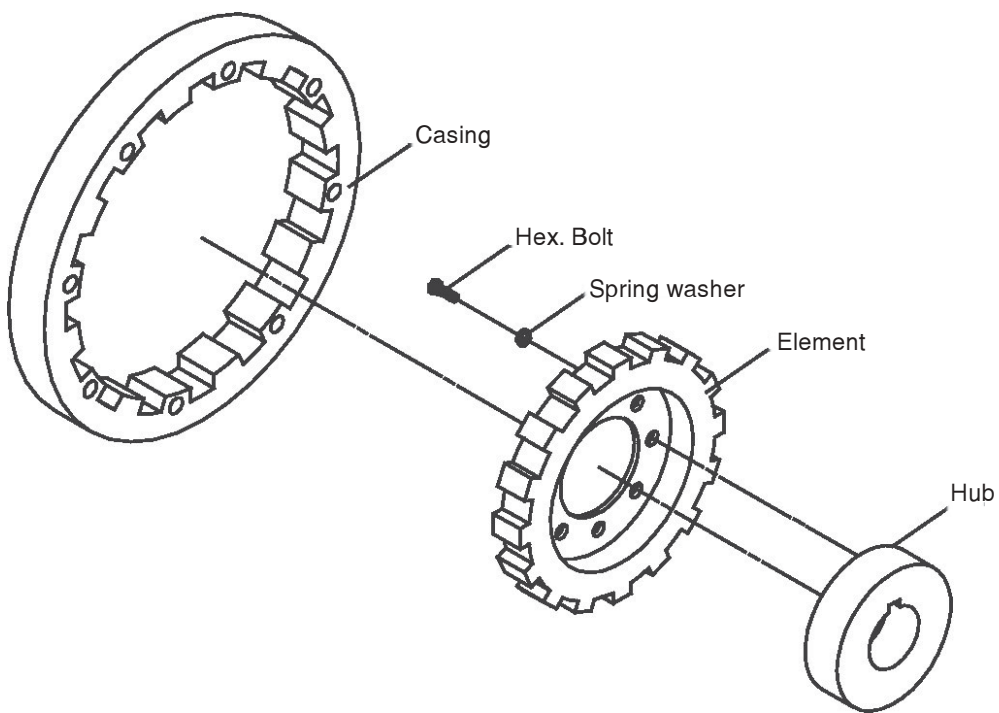

**Drive Coupling**

## Maintenance

### Drive Coupling

#### Dismantling

Whenever major repair/overhauling is carried out on the unit, the airend should be removed. The following dismantling and assembling procedure is to be followed.

- Unscrew the bolts on the engine flywheel.
- Unscrew the bolts on the adaptor ring.
- Remove the airend bottom support screws.
- Lift the airend along with the drive coupling and place it on the work table.
- Unscrew the bolt connecting the rubber element to the hub.
- Using a puller remove the hub from the airend shaft.
- Clean all the components thoroughly. If any component is found damaged, replace it with a new one.

**Use the following torque values for tightening the screws.**

No.	Aluminium casting to fly wheel		Coupling element locking bolts to hub	
	Grade 8.8	Torque (Nm)	Grade 8.8	Torque (Nm)
01	3/8"	34	M16	175

## Maintenance

### Assembling

- Check the engine crankshaft end play using a dial gauge in the following manner. Remove the engine inspection door. Position the crankshaft at any end using any lever and measure the run-out of the crankshaft at the fan side using a dial gauge. Then move the crankshaft to the other end using the lever and measure the end play as well as the run-out.
- Measure the depth of the mating face of the engine housing and engine flywheel.
- Assemble the aluminium drive disc on the flywheel.
- Assemble the adapter ring on the airend mounting face.
- Clean the hub bore and insert it on the compressor shaft using a pusher.
- Assemble the rubber element with the hub.
- Now take the airend to the engine and couple them by clamping the adaptor ring with the engine flywheel.
- Assemble all the components of the drive coupling with the required torque.

#### NOTE

- A drive coupling operating in a correctly assessed system requires no maintenance. It is recommended that the rubber blocks/rubber diaphragm be inspected every 5000 hours.
- A small amount of rubber dust is normal. Large quantities of dust during initial running require inspection. During assembly assemble all components of the drive coupling with the proper torque values.

## Maintenance

### Control System Adjustment

The first step in adjustment of the control system is adjusting the control linkage between the engine governor and actuator. Adjust the slider in such a way that engine reaches its full rated speed when the engine is started. At the full rated speed of the engine the butterfly valve should be fully open or approximately 15–20° off the vertical.

#### NOTE

The value of 15–20° does not apply to the inlet valve lever. The above adjustments have to be made prior to the final adjustments.

### Operating Adjustment

Start the compressor. Allow the unit to operate until the normal operating temperatures are attained. Ensure that the service valve is fully open during this time. Adjust the engine to operate at its full rated speed as per the specification sheet.

### Butterfly Valve Adjustment

The butterfly valve opens and closes with respect to the condition of the service valve. The pressure regulator valve actuates the actuators of both the butterfly valve and the engine governor according to the service pressure requirement.

Clean the butterfly valve after every 1500 hours of running. Remove and clean the centre flap mating surface area.

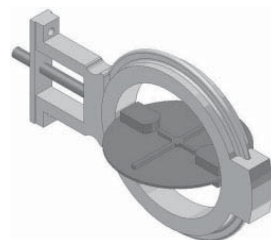

**BUTTERFLY VALVE**

## Maintenance

### Pressure Regulator Valve Adjustment

Turn the pressure regulator valve screw clockwise to ensure that it is out of adjustment. Start closing the service valve slowly till the rated pressure is reached. The engine should operate at the rated speed with the compressor so that a condition is obtained where the engine operates at the rated speed to the rated pressure of the compressor. Turn the pressure regulator valve screw counter-clockwise till the actuator begins to operate. Lock the adjusting screw with a lock nut.

Continue closing the service valve slowly. The speed of the engine reduces while the butterfly valve closes to match the output. At this time the pressure regulator valve adjustment is complete.

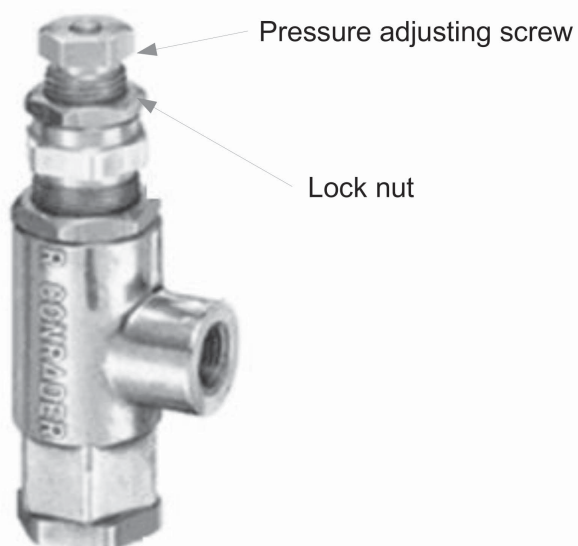

**PRESSURE REGULATOR VALVE**

## Maintenance

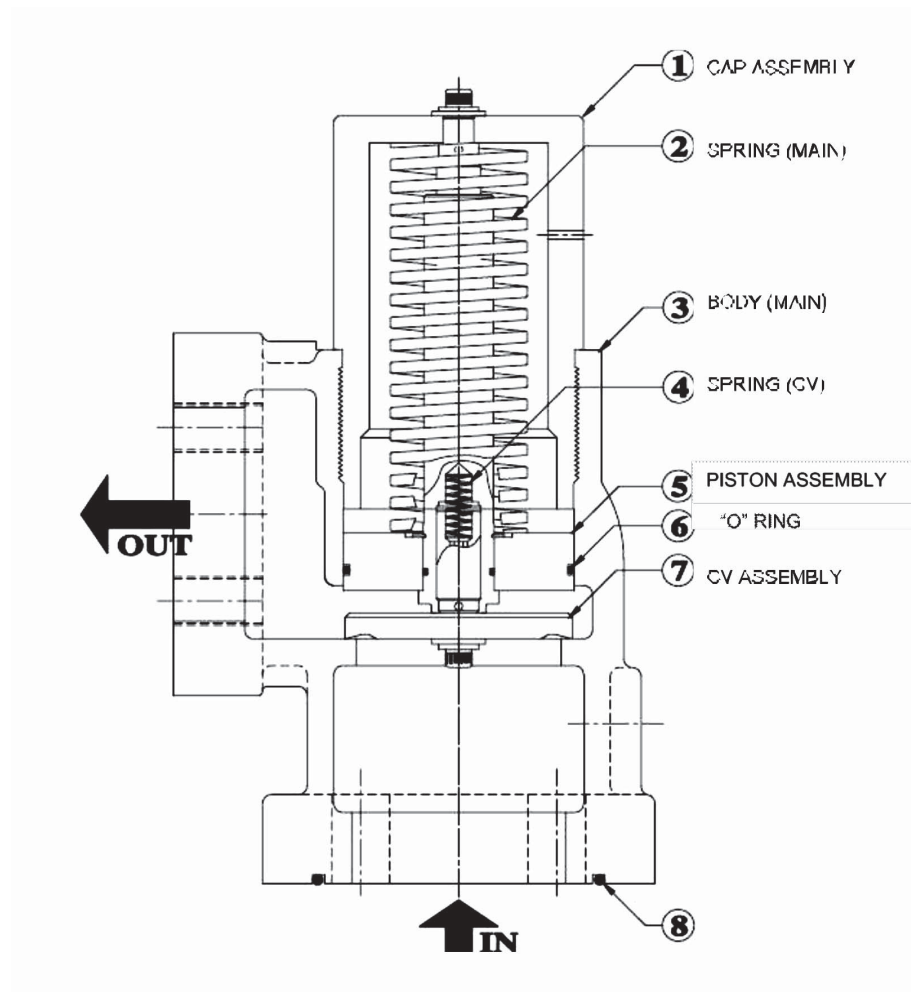

**MINIMUM PRESSURE VALVE**

## Maintenance

### Minimum Pressure Valve

The details of the inner elements of the minimum pressure valve are shown in the accompanying figure.

Minimum pressure valve maintenance is quite minimal. The only part which normally requires replacement is the 'O' ring on the piston.

The minimum pressure valve cover is under heavy spring tension. Loosen the cover bolts alternatively by one turn each to relieve the spring tension.

Before performing maintenance on the valve, be sure that the pressure has been fully relieved in the machine receiver tank and that the downstream pressure has been vented to the atmosphere.

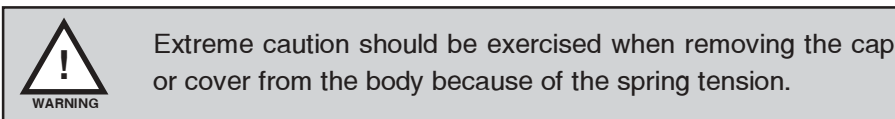

To replace the 'O' ring, follow the procedure explained below.

- Evenly remove the cap to relieve the spring tension.
- Remove the spring.
- Remove the piston.
- Remove the 'O' ring and discard it.
- Clean the piston.
- Replace the 'O' ring.
- Coat the piston and 'O' ring with grease.
- Replace the piston.
- Replace the spring and cap.

## **Maintenance**

---

## Maintenance

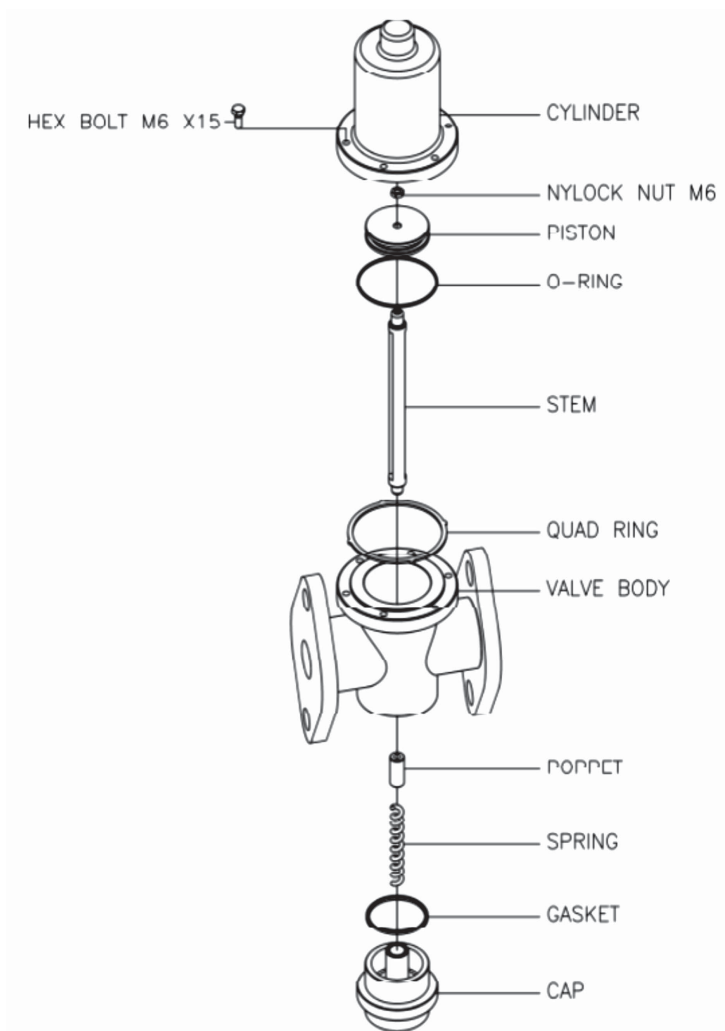

**OIL STOP VALVE**

## Maintenance

### Oil Stop Valve

An exploded view of the oil stop valve is shown in the accompanying figure.

To use the repair kit, follow the instructions given below for proper installation.

- Remove the cap screw securing the cylinder to the valve body and remove the cylinder. Inspect for scratches, scoring, etc.
- Disassemble the 'O' ring from the stem by removing the nylock nut at the end of the stem.
- Discard the 'O' ring and nylock nut. Replace these with the new ones provided in the kit. When reassembling, replace the ¼" nylock nut also.
- Remove and replace the valve body 'O' ring. Reassemble the cylinder and the valve body.
- Remove the valve body, cap and spring.
- Remove the valve seat from the stem by unscrewing it. Replace it with a new one.
- Remove and replace the gasket between the valve body cap and the valve body. Use a new spring.
- Reassemble the spring and cap.

## Maintenance

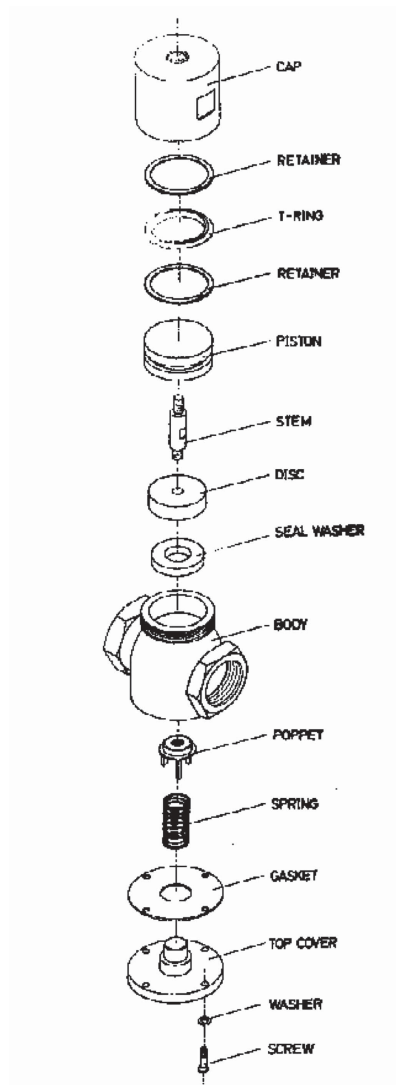

**BLOW DOWN VALVE**

## Maintenance

### Blow Down Valve

An exploded view of the blow down valve is shown in the accompanying figure.

Blow down valve maintenance is limited to replacement of the cover gasket and internal ring and seat.

Using the repair kit, follow the instructions given below for proper installation.

- Remove the four screws on the top cover which hold the assembly together.
- Pull the top cover away from the body.
- Remove the old gasket and replace it with the new one.
- Align the top cover with the body, replace the four screws and tighten.
- To replace the valve seat, loosen and remove the two socket head screws in the bottom cover.
- Pull the bottom cover from the main body.
- Remove the cover ring, spring, seat cup and seat. Discard the seat and ring, and replace them with the new ones in the kit.
- Reassemble the bottom cover.

## Maintenance

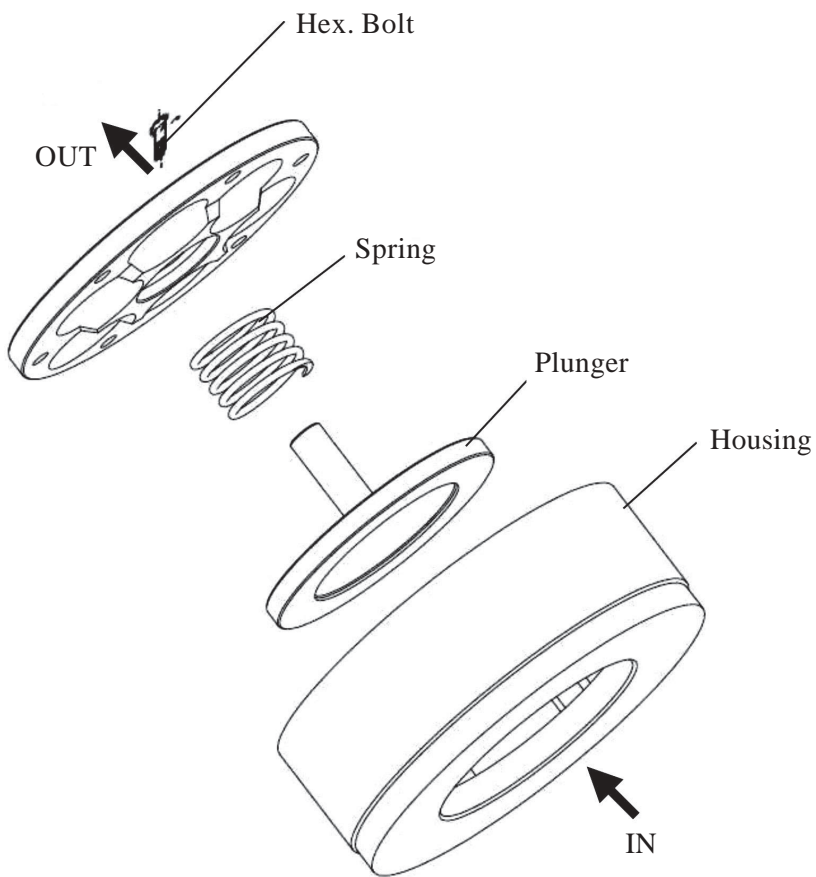

**DISCHARGE CHECK VALVE**

## Maintenance

### Discharge Check Valve

An exploded view of the discharge check valve is shown in the accompanying figure.

To dismantle the discharge check valve, follow the instructions given below.

- Dismantle the flexible hose on the discharge piping between the airtank and the receiver tank.
- Dismantle the hose adapter and the reducing bush fitted on the valve outlet port.
- Unscrew the valve housing from the compressor unit.
- The assembly should now fall away from the compressor unit.
- Remove the three Allen screws on the housing.
- Remove the plug on the housing and loosen the fourth smaller Allen screw.
- The adapter can be separated from the housing.
- Check the spring and plunger for polishing or wear.
- Place the spring and plunger in position on the housing as they were prior to disassembly.
- Replace the plug screws to secure the cover to the housing and reconnect all the disconnected piping.
- Replace the flexible hose and start the machine to check for leaks.

## Maintenance

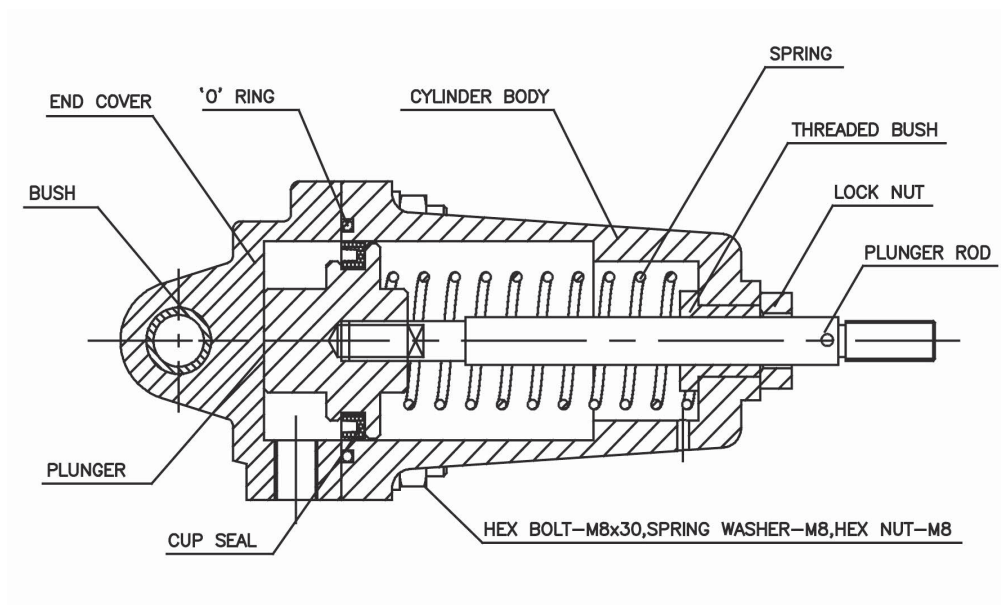

**SINGLE -ACTING ACTUATOR**

## Maintenance

### Single-Acting Actuator

A section view of the actuator is shown in the accompanying figure.

The single-acting actuator requires a maintenance check every 6 months or 1500 hours of operation, whichever is earlier.

During this check, replacement of components is not necessary if they are in a good condition. Thorough cleaning and lubricating of the moving components should be sufficient. But once in a year all the sealing components and the spring have to be replaced.

The procedure is given below.

- Unscrew the bolts and nuts and then remove the end cover and 'O' ring.
- Remove the plunger along with the plunger rod.
- Check the cup seal. Change it if it is found damaged.
- Remove the spring and check the stiffness.
- Replace worn out/damaged components before assembling.

# Maintenance

## Airend Maintenance

This needs special tools, jigs and fixtures for repair work. Please contact the Elgi dealer for any assistance with airend maintenance.

## Oil Cooler and Radiator Maintenance

The compressor unit needs to be shut down before any maintenance work is done on the oil cooler and radiator.

Oil cooler: Remove the ROC canopy cover and clean it using an air jet with a pressure of 3 bar.

Radiator: Remove the fan guard and clean it.

## Battery Maintenance

- Clean the battery and surrounding area with a wet cloth dipped in a diluted washing soda solution to remove the acid on the top. While doing so ensure that the vent plugs are screwed on tight.
- Clean the battery terminals in case they are corroded.
- Apply petroleum jelly or Vaseline on the battery terminals and fixing clamps.
- If the level is low, top up with distilled water/DM water only (up to the maximum level).
- Check specific gravity of each cell at least once every 30 days in a vehicle, and if the gravity is less than 1.19, put the battery on bench charge after topping up to the maximum level.
- When installing batteries in series (two-battery systems—2V), ensure that both the batteries have the same specific gravity.
- The electrolyte in the battery should be maintained up to the upper level only.
- Always keep the battery surface dry and dust-free.

## Maintenance

- Check for the following voltage setting:
- Open circuit voltage: 12.5 V per 12 V battery
- On top of charge voltage: 15.9 to 16.5 V per 12 V battery
- On H.R.D. for 15 seconds: 10.5 V per 12 V battery
- Vehicle charging voltage: 13.5 to 14.2 V per 12 V battery.
- Ensure that the batteries are checked every month as per the checklist.
- Ensure that charger/charging clips/other tools are clean and in order/charging clips tight & free from corrosion.
- Ensure that batteries are removed and kept away from welding area in case of vehicle Maintenance.

**NOTE**

During replacement, compulsorily all the components should be thoroughly cleaned and lubricated.

# Maintenance

## Flushing the Compressor

### A. For new compressors

- Drain the previous fluid from the sump, piping, filters and fluid cooler, preferably while the fluid is hot.
- Drain the fluid filter elements.
- Drain thoroughly.

### B. For dirty or varnished compressors.

- Drain the previous fluid from the compressor while the fluid is still hot and change the fluid filter(s).
- Drain the dirty/solidified oil and fill the tank with Cabol 68 (supplied by BPCL) cleaning fluid. Run the unit for 24 hours with this oil and drain completely while it is hot.
- After draining the cleaning fluid, fill with fresh oil. Check the condition of the oil filter and separator every 250 hours.
- After 2 hours drain the cleaner completely and change filter(s) if necessary.
- Fill the compressor with compressor cleaner and allow it to run for 48 to 72 hours. Monitor the filter(s) and change if necessary.
- Drain the compressor cleaner completely, and partially fill (50%) with SULLAIR AWF fluid.
- Run the compressor for 1 hour, drain completely and change filter(s) if necessary.
- Drain thoroughly.
- Submit a fluid sample for analysis after 200 hours run time.

#### Note

During clean-up, watch for differential pressure in the separator. When the sump pressure becomes 10 lb greater than the line pressure, change the separator.

The above procedure is for a machine that is not too badly varnished.

## Trouble shooting

Engine not starting	No fuel.	Check fuel level and add fuel if necessary.
	Clogged fuel filter.	Replace the element.
	Low battery voltage.	Check electrolyte level and add water and recharge if necessary.
	The electrical connections for the following are to be checked 1. Check Engine water temp switch 2. Check Engine oil temp switch 3. Check Engine oil pressure switch 4. Check Compressor low pressure switch 5. Check compressor Temperature switch 6. Check engine solenoid switch 7. Check loose connection in control panel wires.	In any one of the switch the electrical connections (power supply to be checked) and if the power is not coming to the switch please rectify / replace it and ensure that the green light in the control panel is ON at the time of starting.
	Loose battery cables.	Tighten cables.
	Dirty battery cables.	Clean thoroughly.
	Clogged air filter.	Clean or replace the element.
	Engine problems may have developed.	Refer to your Engine Manufacturer
	Fuel not reaching the pump.	1. Checks the NRV fitted before the moisture filter and if necessary replace it. 2. Airlock in diesel hose line to be removed 3. Air Lock in fuel filter 4. O ring not seated properly in fuel filter 5. No fuel in the fuel filter Diesel tank id fitted very below the engine.
	Engine starts and stops immediately	Blown fuse.
Engine oil temperature and water temperature is high		Clean cooler and check for proper ventilation.

## Trouble shooting

Machine shuts down with air demand present	No fuel.	Check fuel level and add fuel if necessary.
	Compressor discharge temperature switch is open.	
	a) Cooling airflow is insufficient.	Clean cooler and check for proper ventilation.
	b) Low oil level in receiver tank.	Add oil.
	c) Dirty oil	Check the colour of oil (minerals in case) and it should be yellowish only. If the colour changed please change oil with filters.
	d) Clogged oil filter	Change oil filter elements.
	Defective discharge temperature switch	Check for a short or open circuit to the fuel solenoid should this check out normal, it would be possible that the temperature switch itself is defective.
	Engine water temperature switch is open.	
	a) Cooling air flow restricted.	Clean the radiator core.
	b) Low water level.	Fill the radiator with adequate water.
	c) Defective switch.	Replace.
	d) Blow fuse in wiring harness.	Check continuity and replace if necessary

## Trouble shooting

No building of Line pressure	Air demand too great.	Check service lines for leaks or open valves.
	Dirty air filter.	Check the filter indicator and change or clean element if required.
	Pressure regulator valve out of adjustment.	Adjust pressure regulator valve according to control adjustment instruction in the maintenance section.
	Defective pressure regulator.	Check diaphragms and replace if necessary.
	Defective minimum pressure valve.	Check and ensure piston is moving freely.
Improper unloading with an excessive pressure builds up causing pressure relief valve to open.	Pressure regulating valve is set too high.	Re-adjust.
	Leak in the control system causing loss of pressure signal.	Check control lines.
	Defective diaphragm in the actuator.	Replace diaphragms. (kit available)
	Defective pressure regulator valve.	Repair the valve. (kit available)
	Inlet valve jammed.	Repair / replace the valve.
	Restriction in the control systems	Check all control lines and components and remove the foreign particles clogging the system.
	Jammed control linkage. Clogged air/oil separator element.	Free the jammed portion of the linkage and adjust if necessary. Replace separator element.
Insufficient air delivery	Clogged air filter.	Clean or replace the element.
	Clogged air / oil separator.	Replace separator element and also change the compressor oil and oil filter at this time.
	Faulty pressure regulator.	Adjust or repair.
	Engine speed too low.	Re-adjust engine speed.

## Trouble shooting

Excessive compressor oil consumption (Oil carry over through service line)	Clogged return line.	Clean oil return strainer and orifice.
	Check DOT of the unit.	It should be more than dew point temperature. Please refer the chart enclosed in last page of the manual.
	Defective blow down valve.	Replace kit.
	Check moisture level in the sump after shut down the unit	It should be 1/2 litre. If it is more than half litre rain of water from sump. Then replace the higher rated thermal valve.
	Leak in the lubrication system	Check all pipe connections and components.
	Return line orifice choked.	Return line orifice may be choked and needs to be cleaned.
	Seperator element damaged or not functioning properly.	Change seperator element.
	Orifice fitted in wrong position.	Check the orifice and it should be fitted at outlet of return line sight glass.
	Excessive oil in the receiver tank.	Drain to correct level.
	Vertical shell bottom welding condition.	Check welding condition.
Compressor over heating	Loose or broken fan belt.	Tighten or change belt.
	Dirty oil cooler core.	Clean core thoroughly.
	Clogged oil cooler tubes (Internally & externally)	Clean tubes thoroughly.
	Low receiver tank oil level.	Fill up to max. level.
	Clog oil filter.	Clean or change the mainoil filter and bearing oil filter.
	Inter stage Pressure (first stage outlet) is high.	Check the pressure with a guage (provision is given for gauge fitment in first stage outlet cover) and it should be 3.5 bar max. If the pressure is more please contact ELGI for rectification.
	Clogged oil return line.	Clean oil return strainer and orifice.
	Wrong grade of oil.	Drain and flush the system thoroughly. Use recommended grade of oil.
Engine over heating and tripping	Loose or broken fan belt.	Tighten or change belt.
	Dirty radiator core.	Clean core thoroughly.
	Faulty engine thermostats.	Replace thermostats.
	Clogged radiator.	Clean thoroughly.
	Low oil level.	Refill.
	Other engine problems.	Refer to engine manual.
Back flow of oil through suction when unit is stopped	Faulty oil stop valve / DCV / BDV	Check oil stop valve, service if necessary.
		Check discharge check valve
		Check bdv and rectify or replace.
Oil throw through BDV during shut down	Faulty minimum pressure valve	Inspect, rectify or replace the kit.
Moisture condensation in Receiver Tank (Air Oil seperator sump)		

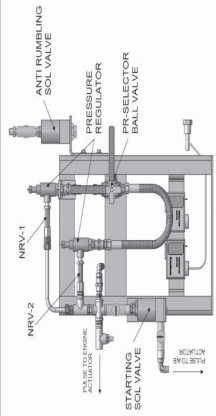
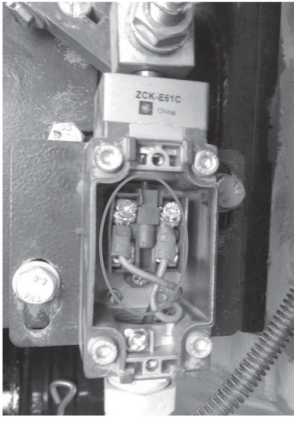
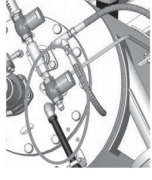
<b>PG1200S – Combo 350, PG1100S - 300 and PG1500S – Combo 400 trouble shooting chart for Pressure raise, safety valve open, unit trip, Heavy vibration at discharge hose and High drilling speed</b>						
SI No	Failure mode	Check points	Probable Root causes	Checking procedure	Trouble shooting	Parts photograph
	Pressure raise, safety valve open, unit trip, Heavy vibration at discharge hose and High drilling speed	No electric supply to Anti Rumbling solenoid coil.	Ensure 24volt supply is coming to the solenoid coil at low idle speed condition	Connector loose in solenoid coil	Connect the wiring as per the drawing	  
		Check solenoid coil orifice clogged	Visual check clogging of solenoid coil internal orifice	Moisture / impurities from air pulse line.	Remove limit switch and confirm the wire connected as per electric circuit. solenoid coil Orifice clean thoroughly	
		Limit switch plunger not pressed fully by butterfly valve lever.	Visual check the limit switch plunger fully pressed by butterfly valve lever while low idle operation (butterfly valve close condition)	Limit switch position dislocated	Remove limit switch and position it properly..	
		Limit switch contact block dislocation	Visual check the limit switch contact block fully pressed by limit switch plunger needle while low idle operation/butterfly valve loose connection in wiring joints	Limit switch Contact block dislocated	Position contact block properly	
		No power supply in Limit switch		Check the connectivity	Connect the wiring as per the drawing	
	Pressure raise, High drilling speed  Pressure raise, safety valve open, unit trip, Heavy vibration at discharge hose and High drilling speed  Pressure raise, High drilling speed	Anti rumbling system BDV condition	BDV struck	Check the BDV plunger for free movement	Clean the BDV thoroughly	
		Leakage in control lines	Low control line pressure to move the actuator	check all the control line joints with soap water	Tighten the leakage joints with proper tool (any spl tools require mention)	
		Butterfly valve	Butterfly valve struck	Check the freeness of the butterfly valve while loading and unloading	Clean / replace the valve	
	Restriction in control lines	Blockage in control lines	Check all control lines	Clean the control lines with compressed air		

	Pressure raise, High drilling speed	Air oil separator condition	Air oil separator element chocking	Check the differential pressure before and after AOS(recommend delta pressure)	Change the AOS	
	Pressure raise, High drilling speed	NRV condition	NRV struck	Remove the NRV and apply air to check for free opening and closing	Change NRV if struck	

**After attending the above trouble shooting points. Following points to be verified and ensured**

**Function of Anti Rumbling safety system checking procedure**

**At any point of time if butterfly valve position or High pressure switch adjusted or replaced, need to ensure the following:**

1. Start the compressor after warming up, keep the compressor to run in high pressure Idle mode
2. Remove the Anti rumbling solenoid coil connection (compressor will run with out anti rumbling kit)
3. Observe the pressure raise till 27 Kg/Cm<sup>2</sup> for PG1200S – Combo 350, 23.5Kg/Cm<sup>2</sup> for PG1100S – 300 and 30Kg/Cm<sup>2</sup> for PG1500S – Combo 400 then unit should trip in 60Secs.
4. If unit is not tripping in 60Sec, reset the butterfly valve to achieve point number 3.

**Function of Anti Rumbling safety system checking procedure indication.**

1. Keep the compressor running in Idle mode
2. Check for indicator "ARS HEALTHY" in glowing condition, which is placed in panel board
3. Remove Anti Rumbling solenoid coil connection (Compressor will run with out anti rumbling kit)
4. Observe the Indicator, it will not Glow.
5. Indicator will not glow when compressor runs in other modes.

**PG1200S - Combo 350, PG1100S - 300 and PG1500S - Combo 400 control system trouble shooting chart**

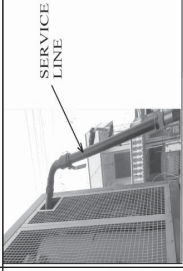
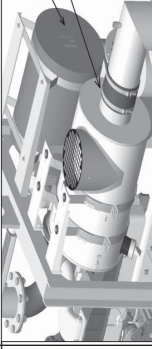
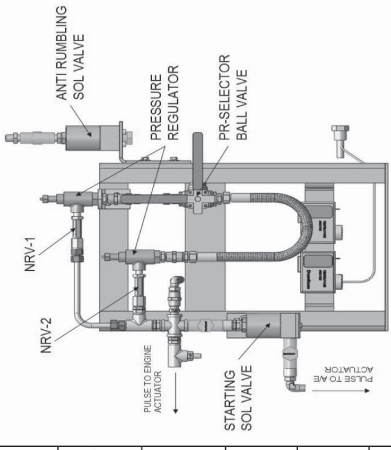
SI No	Failure mode	Check points	Probable Root causes	Checking procedure	Trouble shooting	Details
1	Desired Pressure not building at LP/ (325 for PG1200S – Combo 350, 350 for PG1500S – Combo 400)	Leakage in service line	More air demand	Check service line for leakage or open valves	Arrest all the leakages	
		Air cleaner condition	Clogged air cleaner	Check the filter indicator	clean the air filter elements	
		Non return valve condition	Non return valve malfunction	Remove the non return valve and check the air flow	Clean the non return valve or replace	
		Starting solenoid valve wiring connections	No electrical supply to Starting solenoid valve	Ensure 24volt supply is coming to the solenoid coil at LP and HP mode condition	Connect electrical connections as per the drawing	
		Regulator setting	Wrong regulator setting	Slowly close the outlet ball valve and check the the regulator bleeding at desired pressure (Regulator should bleed at desired pressure)	Reset the regulator setting to the desired pressure	
		Regulator condition	Regulator struck	Remove the regulator kit and check for blockage	Clean the regulator if any blockage observed or replace	
		Starting solenoid valve wiring connections	No electrical supply to Starting solenoid valve	Ensure 24volt supply is coming to the solenoid coil at LP and HP mode condition	Connect electrical connections as per the drawing	
		Non return valve condition	Non return valve malfunction	Remove the non return valve and check the air flow	Clean the non return valve or replace	
		Regulator setting	Wrong regulator setting	Slowly close the outlet ball valve and check the the regulator bleeding at desired pressure (Regulator should bleed at desired pressure)	Reset the regulator setting to the desired pressure	
		Regulator condition	Regulator struck	Remove the regulator kit and check for blockage	Clean the regulator if any blockage observed or replace	
2	Desired Pressure not building at HP/ (350 for PG1200S – Combo 350, 400 for PG1500S – Combo 400)	Starting solenoid valve wiring connections	No electrical supply to Starting solenoid valve	Ensure 24volt supply is coming to the solenoid coil at LP and HP mode condition	Connect electrical connections as per the drawing	
		Non return valve condition	Non return valve malfunction	Remove the non return valve and check the air flow	Clean the non return valve or replace	
		Regulator setting	Wrong regulator setting	Slowly close the outlet ball valve and check the the regulator bleeding at desired pressure (Regulator should bleed at desired pressure)	Reset the regulator setting to the desired pressure	
3	Low Idle speed	Regulator condition	Regulator struck	Remove the regulator kit and check for blockage	Clean the regulator if any blockage observed or replace	
		Regulator setting	Wrong regulator setting	Slowly close the outlet ball valve and check the the regulator bleeding at desired pressure (Regulator should bleed at desired pressure)	Reset the regulator setting to the desired pressure	

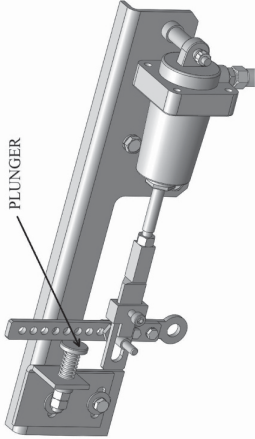
3	Low idle speed	Plunger setting	Wrong plunger setting	Slowly close the outlet ball valve and check the the regulator bleeding at desired pressure (Regulator should bleed at desired pressure)	Set the engine side plunger touches at the engine speed of 1500RPM	
4	High idle speed	Plunger setting	Wrong plunger setting	Check the idle locking screw at engine actuator slider	Adjust the slider to set the desired idle speed	
5	Compressor not starting in second attempt	Leakage in service line Butterfly valve position No electric supply to hard starting kit solenoid coil. MCB position Hard starting solenoid valve leakage	More air demand Butterfly valve fully closed No electrical supply to the hard starting solenoid coil after shutdown MCB switch off Hard starting solenoid valve O ring dislocation	Check service line for leakage of open valves Check for speed increase Ensure 24volt supply to the solenoid coil after shut down Check MCB condition after compressor shutting down Remove the coil and check for O ring condition	Arrest all the leakages Adjust the butterfly valve towards open position Connect electrical connections as per the drawing MCB should not be switched of unless long haul Change solenoid valve if leakage observed	

## Conversion Tables

### Length (l)

From	To	Multiply by
Inches	Millimetres	25.4
Metres	Inches	39.37
Feet	Millimetres	304.8
Metres	Feet	3.281
Inches	Thou	1000
Millimetres	Micrometres	1000

### Area (A)

From	To	Multiply by
Square metres	Square feet	10.765
Square feet	Square inches	144
Square inches	Square Millimetres	645.16

### Volume (V)

From	To	Multiply by
Cubic metres	Cubic feet	35.315
Cubic feet	Cubic inches	1728
Cubic metres	Litres	1000
Cubic feet	Litres	28.32
US gallons (liq)	Litres	3.785
Imperial gallons (liq)	Litres	4.546

### Volumetric flow (Q)

From	To	Multiply by
Cubic feet per minute (cfm)	Cubic metres per hour (m <sup>3</sup> /h)	1.6988
Cubic feet per minute (cfm)	lpm	28.32
Cubic metres per hour (m <sup>3</sup> /h)	lpm	16.667
Cubic metres per minute (m <sup>3</sup> /min)	cfm	35.315

## Conversion Tables

### Mass (M)

From	To	Multiply by
Kilograms	Pounds	2.205
Kilograms	Grams	1000
Kilograms	Ounces	35.27

### Pressure (P)

From	To	Multiply by
Kgf/cm <sup>2</sup> g	Pounds/sq.inch(PSI <sub>g</sub> )	14.223
PSI <sub>g</sub>	Pascals (Pa)	6895
Bar g	kgf/cm <sup>2</sup> g	1.0197
Bar g	PSI <sub>g</sub>	14.503
PSI <sub>g</sub>	kgf/cm <sup>2</sup> g	0.0703

### Temperature (T)

From	To	Conversion
Degrees Celsius (C)	Degrees Fahrenheit (F)	$F = 9C/5 + 32$
Degrees Celsius (C)	Degrees Kelvin (K)	$F = C + 273.15$
Degrees Fahrenheit (F)	Degrees Rankine (R)	$R = F + 460$

### Heat (Q), Work (W), Energy (E)

From	To	Multiply by
Ft-lbf	Joules	1.35582
Ft-lbf	Btu	0.001285
Keal	kgf m	426.9
Joules	Calories	0.2388
Btu/h	Calories/h	252
Kilowatts	Btu/h	3411

### Power (P)

From	To	Conversion
Metric horsepower	Kilowatts	0.7355
Imperial horsepower	Kilowatts	0.7457

## Torque values

The tightening torque values for bolts and screws used in Elgi compressors are provided in this section for reference.

For Metric hex. head bolts and Screws Property Class 8.8

Tightening torque for critical areas							
Critical areas	Thread size						
	M8	M10	M12	M16	M20	3/8" UNC	1/2" UNC
Butterfly valve joint (Gasket)	21	42	78	177	346	37	89
DCV flange joint (Gasket)	21	42	78	177	346	37	89
Tank top plate joint (Gasket)	21	42	78	177	346	37	89
Fly wheel joint (Aluminium)	21	42	78	177	346	37	89

### Cone nut joints

Thread size (inches)	Tightening torque (Nm)
1/4"	10
3/8"	32
1/2"	41
3/4"	53
1"	72
1 1/4"	135
1 1/2"	195

### Hose adaptor joints

Thread size (inches)	Tightening torque (Nm)
1/4"	13.5 to 15
3/4"	95 to 106
1"	127 to 141
1 1/4"	168 to 187
1 1/2"	211 to 234

## Torque values

### UNC hex. head bolts and screws Grade 5

Thread size (inches)	Tightening torque (Nm)
1/4	12
5/16	23
3/8	41
7/16	65
1/2	99
5/8	193
3/4	341
7/8	550
1	824

### For UNF Hex. Head Bolts & Screws Grade 5

Thread size (inches)	Tightening torque (Nm)
1/4"	13
5/16"	25
3/8"	46
7/16"	73
1/2"	111
5/8"	217
3/4"	379
7/8"	602
1"	898

### For NPT Fittings (All Steel Fittings)

Thread size (inches)	Tightening torque (Nm)
1/8"	12
1/4"	18
3/8"	22
1/2"	45
3/4"	58
1"	79
1 1/4"	149
1 1/2"	285
2"	420

## Disclaimers

- The entire literature including product description or any other information in the manual exclusively belongs to Elgi and is subject to copyright. No person has any right to copy, modify, distribute, transmit, display, perform, reproduce, publish, licence, create derivative works, transfer or sell any information, or deal with the same in any other manner, without the knowledge and written concurrence of Elgi, violation of which would amount to infringement of rights of Elgi and would necessitate legal action.
- Elgi Equipments Ltd. is the exclusive owner of the trade name or mark 'ELGI' or any other mark, whether registered or not, represented in any manner whatsoever in the said manual and any person who does any act or omission, which is an infringement or which is tantamount to infringing the said mark shall be doing so at the risk of legal action and besides being held liable for infringement shall be liable for payment of damages including loss of profits.
- The information published in this manual may include inaccuracies, or typographical errors. Changes may be periodically added to the information herein. Any changes/improvements may also be made to the products stated in the said manual and Elgi is not liable if the readers are not updated with information.
- Likewise Elgi is responsible only till the point of first sale to the ultimate customer and not thereafter and only from authorized dealers of Elgi; Elgi shall disown liability on the purchase of any secondhand machine or purchase otherwise from authorized dealers. Elgi shall not be liable for any indirect, incidental, punitive, special or consequential damages arising out of or in any way connected with the usage of the products or information in the said manual.
- Even in respect of users of the products Elgi's liability is limited to the value of the product.
- Any dispute pertaining to the said manual or anything stated therein or any product stated therein is subject to the exclusive jurisdiction of the courts in Coimbatore.



## Business Reply Card

To

The Marketing Department,  
Elgi Equipments Limited,  
Singanallur,  
Coimbatore

From

Name:  
Position:  
Name of organisation:  
Address:  
Telephone number:  
Email address:  
Date:

I would like to have more information on the following the Elgi products and services :

- Electric driven rotary screw compressors
- Diesel powered rotary screw compressors
- Oil-free rotary screw compressors
- Driers
- Filters
- Reciprocating compressors
- Vayu compressors
- Dr. Vayu compressors for dental applications
- Air Lube oil and other coolants
- Maintenance services
- Please send me your literature
- Ask your Sales Engineer to call on me





