

Instruction Manual

۱۳۶۲
جهان کمپرسور

➤ JUNIOR II



INTRODUCTION

This manual contains operating instructions and maintenance schedules for the high pressure breathing air compressor unit

Junior II

WARNING

! Pneumatic high pressure system !

The breathing air produced with the compressor units described in this manual is subject to strict quality standards. Ignoring the operating and maintenance instructions can lead to severe injury or death.

This compressor has been built in accordance with the EC machine regulations 98/37/EG. Specifications on the noise level in accordance with the machine and product safety law as of 01.05.2004 and the EC machine regulations, chapt. I, section 1.7.4. The machine has been built according to the highest standard of technology and the generally acknowledged safety standards. Nevertheless, operation could still cause danger for the operating personnel or third parties, or result in damage to the machine and other values. The machine may only be used to produce compressed air as specified in this manual. Other use is strictly prohibited.

All instructions should be observed and carried out in the order laid down to prevent damage and premature wear to the equipment.

The manufacturer and the supplier void all responsibility for damage or injury resulting from failure to follow these instructions.



Edition January 2009

© 2009 BAUER Kompressoren GmbH, München
All rights reserved

Dear customer

We are happy to give you advice on any questions regarding your **BAUER** compressor and help as soon as possible with any arising problems.

You can contact us Mondays to Thursdays from 08⁰⁰ till 16³⁰, Fridays from 08⁰⁰ till 14⁰⁰ on phone no. (089) 78049-0.

If you call the following extensions directly, it will save you time and continuous dialling.

Do you want to order spare parts?

Customer service

Phone no: (089) 78049-129 or -149

Fax no: (089) 78049-101

Do you have problems with maintenance or repair work?

Technical customer service

Phone no: (089) 78049-246 or -176

Fax no: (089) 78049-101

Do you need further information regarding your unit, accessories, prices etc.?

Sales department

Phone no: (089) 78049-138, -185, -154, -205 or -202

Fax no: (089) 78049-103

Are you interested in any training courses?

Training manager

Phone no: (089) 78049-175

Fax no: (089) 78049-103

Explanation of the short operating instructions on the unit

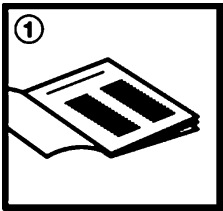

Read instruction manual before operating unit

☞ chapter 3.

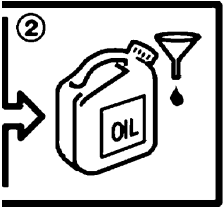

Check oil level on compressor and petrol engine before operating unit

☞ chapter 4.4.1.

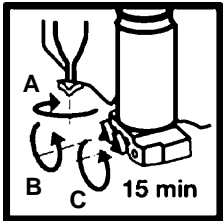

Drain condensate at least every 15 minutes (3 locations)

☞ chapter 4.4.3. and 4.4.4.

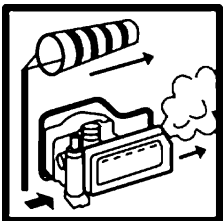

Position units with petrol engine with exhaust in wind direction to prevent exhaust fumes being sucked in by the compressor

☞ chapter 3.

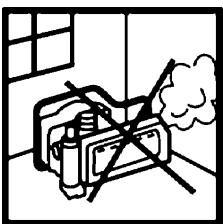

Petrol driven units must not be operated indoors.

☞ chapter 3.

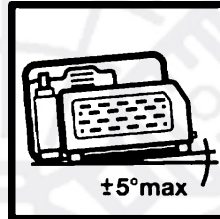

Position unit level: max. inclination 5°

☞ chapter 3.

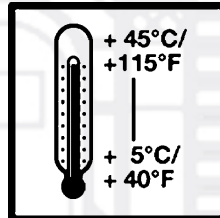

Operate unit only at ambient temperatures between +5 and +45 °C

☞ chapter 3.



Keep away from hot surfaces on motor and compressor

☞ chapter 2.

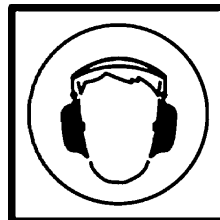

Wear ear protectors when unit is running

☞ chapter 2.

CONTENTS

1.	GENERAL	1
2.	SAFETY MEASURES	5
3.	LOCATION, OPERATION, BOTTLE FILLING ..	9
4.	MAINTENANCE	17
5.	STORAGE, PRESERVATION	31
6.	REPAIR INSTRUCTIONS	32
7.	TABLES	33
8.	ANNEX	35

INDEX

A

Adhesive chart, 34
Air flow diagram, 1
Annex, 35

B

B-Timer, 13

C

Change-over device, 12
Cooling system, 28

D

Design, 1
Drive system, 27

E

V-belt, tension meter, 27
Electrical system, 28

F

Filling procedure, 10
Filter system, 19

I

Intake filter, 18
Intermediate separator, 19
Intake air quality, 10

L

Location, 9
Lubrication, 17
Lubrication chart, 34

M

Maintenance, 17

Maintenance instructions, 17
Maintenance record, 17
Maintenance schedule, 17
Motor protection switch, 28

O

Oil change, 18
Oil level check, 17
Oil type, 17
Operation, 9

P

Preservation, 31
Pressure gauge, 24
Pressure-maintaining valve, 23

R

Repair instructions, 32

S

Safety valves, 24
Sealant chart, 34
Shut-down, 12
Storage, 31

T

Tables, 33
Technical data, 4
Telescopic intake tube, 18
Testing agents, 34
Tightening torque values, 33
Torque sequence, 33
Trouble-shooting, 29

V

Valves, 25

ANNEX

Schematic diagram motor protection switch, three phase current	76942-S1
Lubricating oil list	70851
Applicable parts list	TJ-4/9

NOTES

Model:

Serial No.:

Date of purchase:

Dealer address / phone no.:

.....

.....

.....

.....

.....

.....

.....

.....

.....

.....

.....

.....

.....

.....

.....

.....

.....

.....

.....

.....

.....

.....

.....

.....

.....

.....

.....

.....

.....

.....

.....

.....

.....

.....

.....

.....

.....

.....

.....

.....

.....

.....

.....

.....

.....

.....

.....

.....

.....

.....

.....

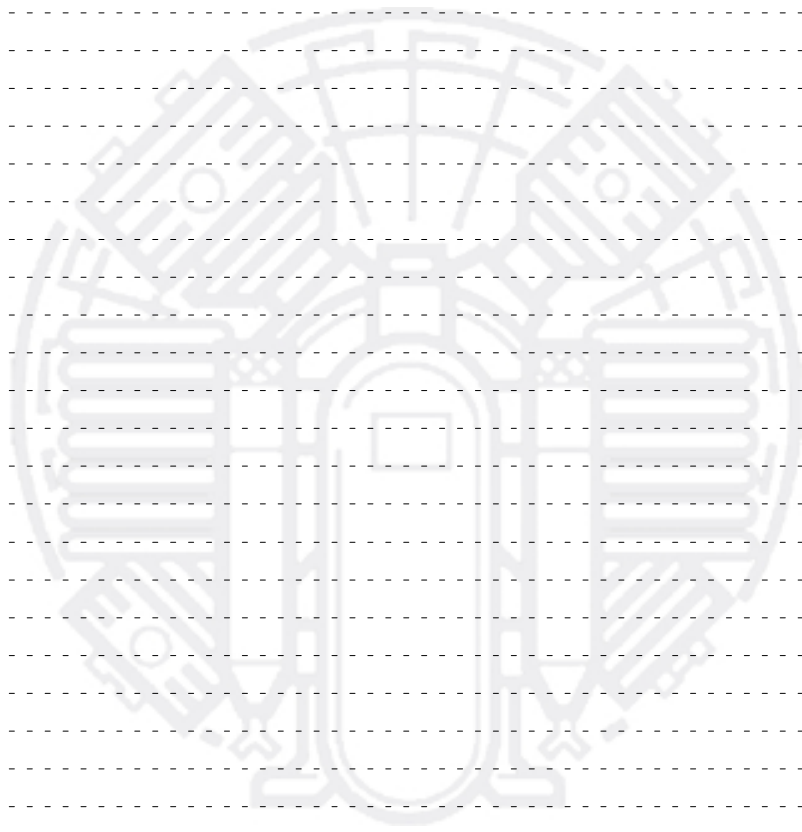

1. GENERAL

PURPOSE

The **JUNIOR II** breathing air compressor is designed to compress air for breathing as required in diving applications. The max. allowable operating pressure (adjusted pressure on final pressure safety valve) is 225 bar or 330 bar.

DESIGN

The compressor unit comprises the following major assemblies:

- compressor block
- drive motor
- filter system P21
- filling assembly
- base plate and frame

The design of the compressor system is shown in Abb. 1 to Abb. 4.

AIR FLOW DIAGRAM

See Abb. 5 . The air is drawn in through telescopic tube (necessary for units with petrol engine) -1, intake filter -2; compressed to final pressure in cylinders -3, -4, -5; recooled by intercoolers -6, -7, and aftercooler -9. The pressures of the single stages are protected by safety valves -10, -11, -12. The compressed air is pre-cleaned in intermediate separator -8 and purified in filter system P21 -13. Intermediate separator and filter system P21 are drained by means of condensate drain valves -15. Pressure maintaining valve -16 provides a constant pressure within the filter assembly. The compressed, purified air is passed through filling hose -17 and filling valve -18 to the bottles to be filled. Filling pressure is indicated at pressure gauge -19. With the change over device model it is possible to fill bottles with 200 bar nominal pressure, just by opening valve -21 at filling valve -18. Safety valve -20 is adjusted to a blow off pressure of 225 bar.



Abb. 1 Compressor unit with petrol engine

- | | |
|---|--|
| <ul style="list-style-type: none"> 1 Filling hose 2 Exhaust 3 Air filter 4 Tank 5 Throttle lever 6 Choke lever 7 Fuel cock | <ul style="list-style-type: none"> 8 Starter rope 9 Engine stop switch (ignition) 10 Filling valve with final pressure gauge 11 Safety valve, final pressure 12 Filter system P21 13 B-Timer 14 Condensate drain taps |
|---|--|

- 1 Filling hose
- 2 Filling valve with pressure gauge
- 3 Motor terminal box
- 4 Three-phase motor
- 5 Final pressure safety valve
- 6 Handle
- 7 Fanwheel cover
- 8 B-Timer
- 9 Condensate drain valves
- 10 Mains plug with ON-OFF switch and motor protection circuit breaker (dep. on country)

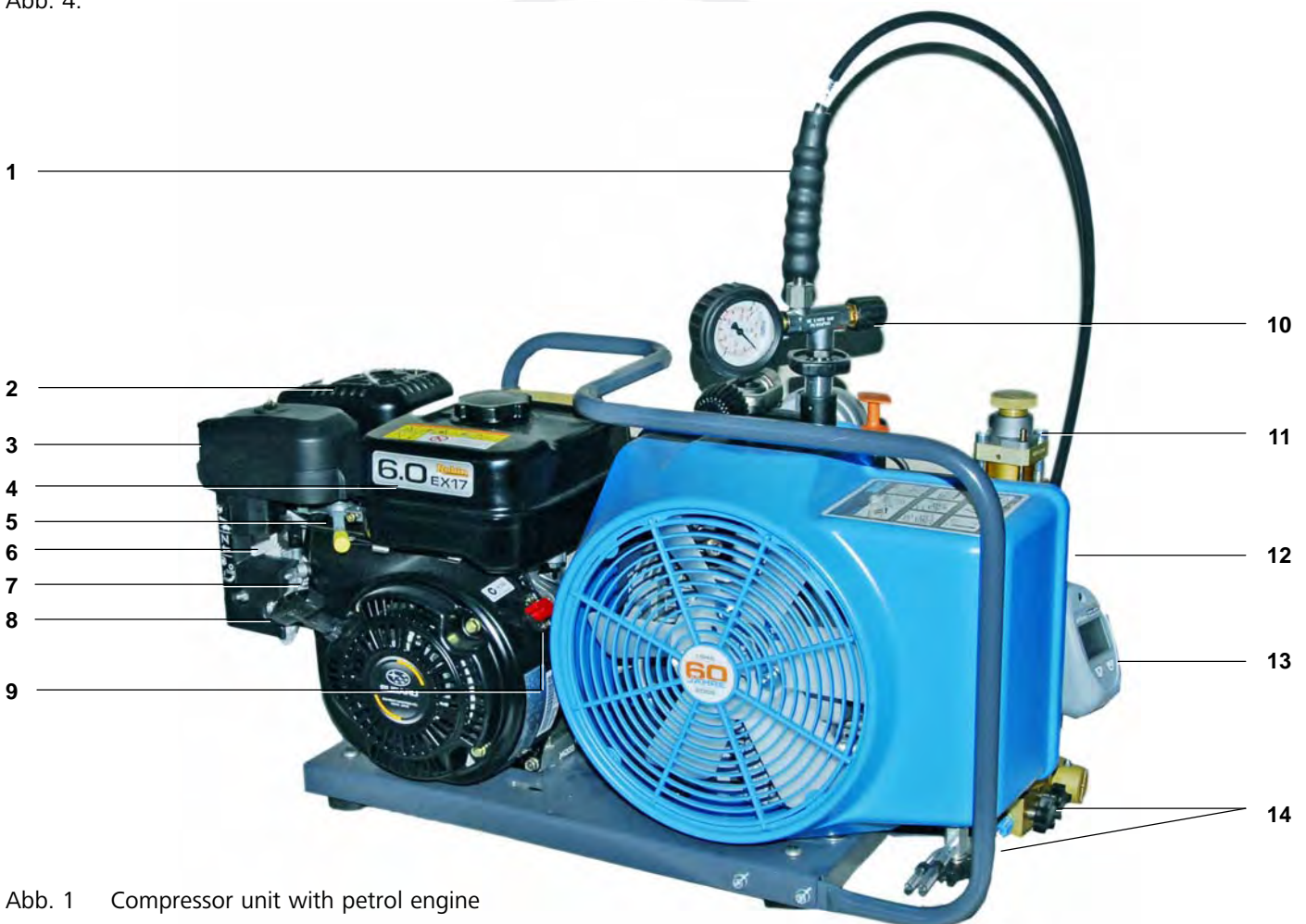

Abb. 2 Compressor unit with electric motor (three-phase current)

- 1 Filling hose
- 2 Filling valve with pressure gauge
- 3 Motor terminal box with ON-OFF switch
- 4 Single-phase motor
- 5 Final pressure safety valve
- 6 Handle
- 7 Fanwheel cover
- 8 Pressure maintaining valve
- 9 Condensate drain valves



Abb. 3 Compressor unit with electric motor (alternating current)



- 1 Filling hose
- 2 Filling valve with pressure gauge
- 3 Final pressure safety valve
- 4 Filter system P21
- 5 B-Timer (optional)
- 6 Pressure maintaining valve
- 7 Filling connector
- 8 Intake filter
- 9 V-belt cover

Abb. 4 Compressor unit with electric motor, v-belt cover side

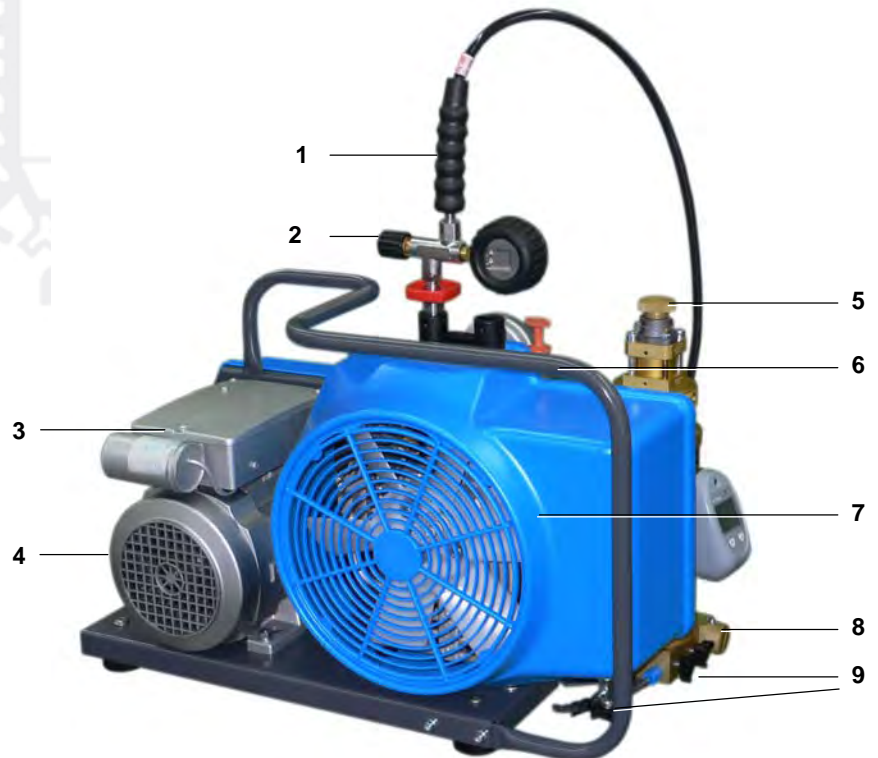
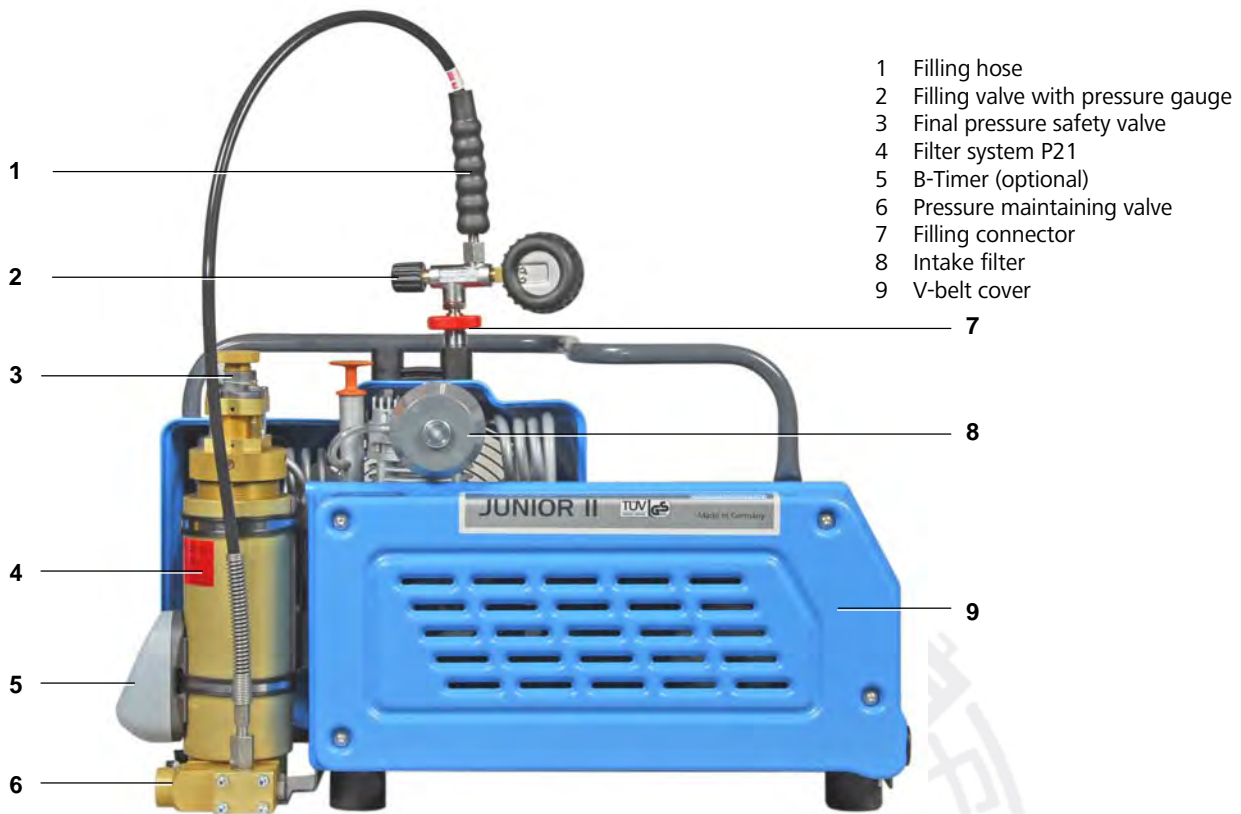
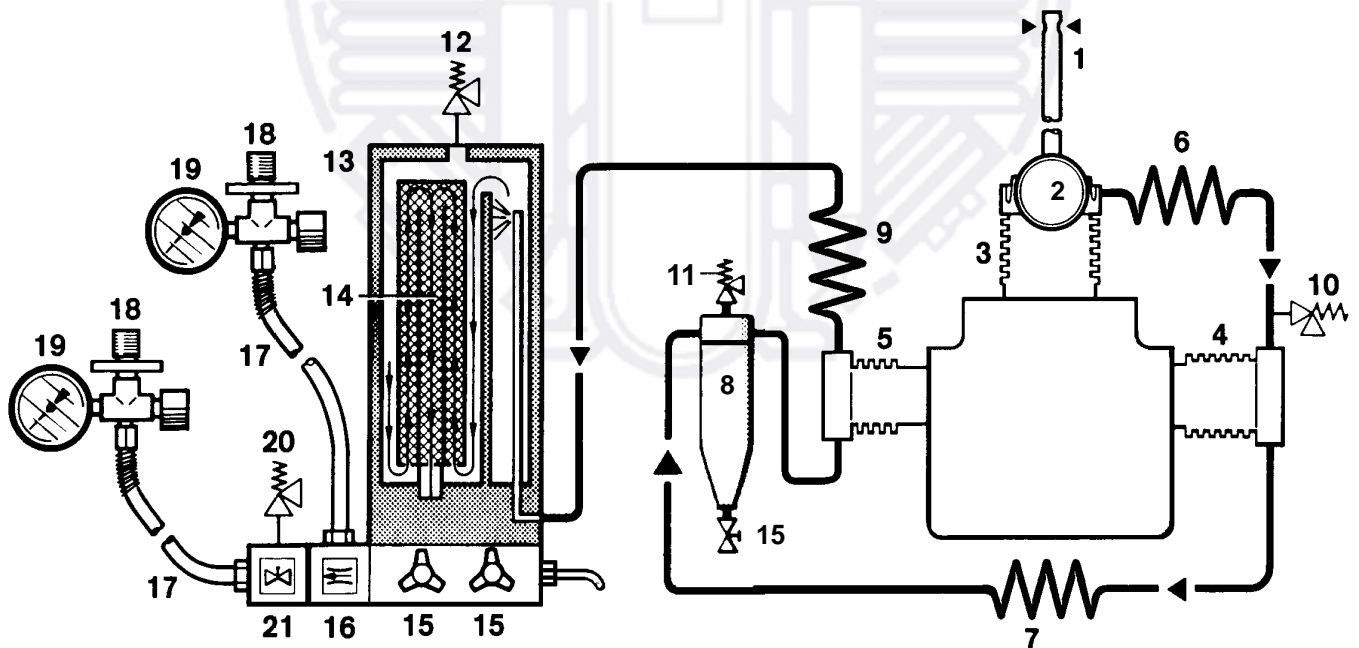

- 1 Telescopic air intake
- 2 Intake filter
- 3 Cylinder 1st stage
- 4 Cylinder 2nd stage
- 5 Cylinder 3rd stage
- 6 Inter-cooler 1st/2nd stage
- 7 Inter-cooler 2nd/3rd stage
- 8 Intermed. separator 2nd/3rd stage
- 9 After-cooler
- 10 Safety valve 1st stage
- 11 Safety valve 2nd stage
- 12 Final pressure safety valve
- 13 Filter system P21
- 14 TRIPLEX longlife cartridge
- 15 Condensate drain valve
- 16 Pressure maintaining valve
- 17 Filling hose
- 18 Filling valve
- 19 Final pressure gauge
- 20 Safety valve, final pressure PN 200
- 21 Change over device (optional extra)

Abb. 5 Air flow diagram

TECHNICAL DATA

Compressor unit	JuniorII-B-F01	JuniorII-E	JuniorII-W
Medium	air		
Delivery ^{a)}	100 l/min. (3,5 Scfm)		
Operating pressure	PN200/PN300		
Pressure setting, final pressure safety valve	225/330 bar		
Sound pressure	87 dB(A)	86 dB(A)	
Sound (immersion) power	100 dBA)	99 dB(A)	
Weight	46 kg	44 kg	47 kg
Compressor block	Junior, mod. 3		
Number of stages	3		
Number of cylinders	3		
Cylinder bore 1st stage	60 mm		
Cylinder bore 2nd stage	28 mm		
Cylinder bore 3rd stage	12 mm		
Piston stroke	24 mm		
Speed	2,300 min ⁻¹		
Intermediate pressure 1st stage	6-7 bar		
Intermediate pressure 2nd stage	40-60 bar		
Compressor block oil capacity	360 ml		
Oil volume between min. and max. marks	50 ml		
Oil type	see chapter 4.4.1. lubrication		
Max. ambient temperature	+5 ... +45 °C		
Max. inclination of compressor ^{b)}	5°		
Max. operating height	0 ... 2000 m above sea level		
Compressor drive	JuniorII-B		
Drive motor	Robin/Subaru petrol engine		
Manual start model (B)	EX17		
Power	4.2 kW (5.7 PS)		
at nominal speed	3,600 min ⁻¹		
Compressor drive	JuniorII-E		
Drive motor	Three phase current		
Operating voltage	400 V, 50 Hz		
Power	2.2 kW (3 PS)		
Speed	2,850 min ⁻¹		
Size	90 L		
Type of construction	B3		
Type of enclosure	IP54		
Compressor drive	JuniorII-W		
Drive motor	Alternating current		
Operating voltage	230 V, 50 Hz		
Power	2.2 kW (3 PS)		
Speed	3,000 min ⁻¹		
Size	LS 90 PC		
Type of construction	B3		
Type of enclosure	IP44		

a) free air delivered at bottle filling from 0 to 200 bar ±5%

b) these values are valid only if the oil of the compressor in normal position corresponds with the upper mark of the oil dipstick and may not be exceeded.

2. SAFETY MEASURES

2.1. NOTES AND WARNING SIGNS

Notes and warning signs displayed on compressors according to model, application or equipment.



WARNING

Hot surfaces, do not touch!

Danger of burning by touching cylinders, cylinder heads and pressure lines of individual compressor stages.



WARNING

High voltage!

Life threatening danger of electric shock. Maintenance work on electric units or operating equipment may only be carried out by a qualified electrician or by a person instructed and supervised by a qualified electrician according to electrical regulations.



WARNING

Automatic compressor control, unit may start-up without warning!

Before carrying out maintenance and repair work, switch off at the main switch or disconnect from the mains and ensure unit will not restart.



MANDATORY

Instructions must be read by persons operating the machinery!

The instruction manual supplied and all other applicable instructions, regulations etc. must be read and understood by operating personnel before using the machine.



MANDATORY

Hearing protectors must be worn!

Hearing protectors must be worn when working on a machine which is running.

NOTE



Ensure correct direction of rotation!

When switching on the machine, check the arrow to ensure correct direction of rotation of the drive motor.

2.2. IDENTIFYING THE SAFETY NOTICES

Important instructions concerning the endangerment of personnel, technical safety and operating safety will be specially emphasized by placing the following signs before the instructions.



This notice is used with maintenance work and operating procedures and must be adhered to exactly in order to avoid endangering personnel.



This notice must be complied with in order to avoid damage to or destruction of the machine or its equipment.



This notice advises of technical requirements which the operator must take particular note of.

2.3. FUNDAMENTAL SAFETY NOTICES

2.3.1. Authorized use

- The machine / unit is built according to state of the art technology and established safety technical regulations. Nevertheless, its use can cause danger to life and limb of the operator or third parties or damage to the machine and other equipment.
- Operate the machine / unit only in technically perfect condition in accordance with regulations and safety and danger notices detailed in the instruction manual! In particular, immediately correct faults (or have them corrected) which can impair safety!
- The machine / unit is exclusively for the compression of mediums (air/gas) specified in section A, chapter 1.3. "Technical data". Any other medium or use outside that specified is not authorized. The manufacturer / supplier is not liable for damage resulting from this. The user alone is responsible for this risk. Authorization for use is also under the condition that the instruction manual is complied with and inspection and maintenance requirements are enforced.

2.3.2. Organizational measures

- Keep the instruction manual to hand near the machine / unit at all times in the relevant holder.
- In addition to the instruction manual, observe and comply with universally valid legal and other obligatory regulations regarding accident prevention and environment protection. See chapter 2.4. This can involve, for example, contact with hazardous substances or the provision / wearing of personal protective equipment.
- Personnel engaged to operate the machine must have read the instruction manual before beginning work, es-

pecially the safety notices chapter. When work is already underway it is too late. This is particularly relevant for temporary personnel, e.g. maintenance personnel.

- Personnel may not wear long hair loose, loose clothing or jewellery, including rings. There is a danger of injury through, for example, these getting caught or being pulled into the equipment.
- As far as necessary or according to regulations, use personal protective equipment.
- Observe all safety and danger notices on the unit.
- Keep all safety and danger notices on the machine / unit complete and in readable condition.
- If there are any modifications to the unit or operating conditions which may affect safety, stop the unit immediately and inform the person responsible of the fault.
- No modifications may be made to the unit which could impair safety without first obtaining permission from the suppliers. This is also the case with regard to installation and adjustment of safety devices and valves as well as welding of piping and reservoirs.
- Spare parts must always comply with the technical requirements specified by the manufacturer. This is always guaranteed with original spare parts.
- Piping must be thoroughly checked (pressure and visual inspection) by the operator at appropriate time intervals, even if no safety related faults have been noticed.
- Intervals stipulated or given in the instruction manual for recurring checks / inspections must be adhered to.
- Make sure location and operation of fire extinguishers is known.
- Pay attention to fire warning and fire fighting procedures.

2.3.3. Qualifications, fundamental duties

- Work on / with the unit may only be carried out by reliable personnel. Observe the legal minimum age permissible.
- Ensure that only trained personnel work with the machine.
- Establish the responsibilities of the machine operator and establish a procedure for him to inform a third person of unfavourable safety conditions.
- People who are being trained or introduced to the job should only be allowed to work with the unit under constant supervision of an experienced person.
- Work on the electrical equipment of the unit may only be carried out by a qualified electrician or by an instructed person under the direction and supervision of a qualified electrician according to electrotechnical regulations.

2.3.4. Safety notices for operation

- Do not carry out any work if safety is questionable.
- Meet all requirements demanding that the unit is only operated in safe and good working order. Only operate the machine if all protective and safety equipment, e.g. all detachable protective equipment, emergency shut-down

devices, soundproofing is provided and in good working order.

- At least once every day, check the unit externally for damage and faults. Inform the person responsible immediately if anything is not as it should be (including operation). If necessary, shut the machine down immediately and make it safe.
- Observe switching on and off processes and monitoring indications according to the instruction manual.
- Before switching on / starting up the unit, ensure that no one can be put at risk through running the unit.
- Carry out the setting, maintenance and inspection processes at the intervals specified in the instruction manual, including replacement of parts / equipment. This work may only be carried out by qualified personnel.
- Clear and make the maintenance area safe as far as necessary.
- If the unit is completely switched off for maintenance and repairwork, ensure that it is protected from unexpected start-up. Turn off main control device and remove the key and / or display a warning sign on the main switch.
- When replacing individual parts and larger assembly groups, they must be carefully fastened to the lifting device so that there is no risk of danger. Use only suitable and technically perfect lifting devices and equipment with sufficient lifting power and strength. Do not linger or work under suspended loads.
- Only entrust an experienced person with the fixing of loads and guiding of crane drivers. The person guiding must remain within sight or in contact with the operator.
- For assembly work above body height, use appropriate safety approved equipment, e.g. ladders and platforms. Do not climb on machine parts. For maintenance work at high levels, wear a safety harness.
- Clean oil, fuel or care products from the machine, in particular the connections and screw joints, before carrying out maintenance / repairwork. Do not use aggressive cleaning fluid. Use a fibre-free cleaning cloth.
- Before cleaning the machine with water or jet of steam (high pressure cleaner) or detergent, cover / seal all openings which for safety and/or operating reasons no water / steam / detergent may penetrate. Electric motor and switch cabinets are particularly at risk.
- When cleaning the operating room, ensure that the temperature sensors of the fire alarm and sprinkler system do not come into contact with hot cleaning fluid, in order to avoid triggering the sprinkler system.
- Completely remove all covers / seals after cleaning.
- After cleaning, check all pressure lines for leaks, loose connections, wear and damage. Immediately eliminate any faults.
- Always retighten any screw connections loosened for maintenance or repairwork.
- If it is necessary to remove safety devices for maintenance and repairwork, these must be replaced and checked immediately after completion of the maintenance or repairwork.

- Ensure safe and environmentally friendly disposal of consumables and old parts.

2.3.5. Particular areas of danger

- Use only original fuses with specified current rating. If there is a failure in the electric energy supply, shut the unit down immediately.
- Work on electric units or operating equipment may only be carried out by a qualified electrician or by a person under the instruction and supervision of a qualified electrician according to electric technical regulations.
- Machines and unit parts which must undergo inspection, maintenance and repairwork, must be disconnected from the mains supply, if specified. Parts which have been disconnected must first be checked for voltage, then earthed and short-circuited and isolated from live neighbouring parts.
- The electrical equipment of a unit must be regularly checked. Defects, such as loose screw connections or burnt wires, must be rectified immediately.
- If work is to be carried out on live parts, work with a second person who can operate the emergency off switch or the main switch in the case of an emergency. Close off the work area with a red and white safety chain and a warning sign. Only use voltage isolated tools.
- Only personnel with particular knowledge and experience with pneumatics may carry out work on pneumatic equipment.
- Check all pressure lines, hoses and screw connections regularly for leaks and visible damage. Immediately repair any damage. Escaping air under pressure can cause injury and fire.
- Depressurize system and pressure lines before commencing repairwork.
- Pressurized air lines must be laid and mounted by qualified personnel. Connections must not be mixed up. Fittings, length and quality of the piping must correspond to requirements.
- Soundproofing equipment on the unit must be in place and functional during operation.
- The stipulated hearing protectors must be worn.
- With regard to oil, grease and other chemical substances, observe the relevant safety regulations for the product.
- For loading, only use lifting device and equipment with sufficient lifting power and strength.
- Use only suitable transporters with sufficient carrying power. Secure the load properly. Use suitable fixing points.
- If necessary, provide unit with transportation brackets. Display the appropriate notice. Remove transportation brackets in the correct manner before taking into operation.
- Parts which need to be dismantled for transport purposes must be carefully replaced and secured before taking into operation.

- Even when moving the unit only slightly, the unit must be disconnected from all external energy sources. Before putting into use again, reconnect the machine to the mains according to regulations.
- When taking back into operation, proceed according to the instruction manual.

2.3.6. Notices of danger regarding pressure vessels

- Never open or loosen pressure vessel lids or pipe connection parts under pressure; always depressurise the vessel or the unit.
- Never exceed the permissible operating pressure of the vessels!
- Never heat the vessels or any of their parts above the stated, maximum operating pressure.
- Always exchange damaged pressure vessels completely. Individual parts that are subject to pressure loads cannot be purchased as spare parts, since the vessels are tested as a complete part and the documentation considers them as a whole (see pressure vessel documentation, serial-numbers!).
- Always pay attention to the permissible operating mode of the pressure vessels.

We differentiate:

- vessels for static load
- vessels for dynamic load

Vessels for static load:

These pressure vessels are permanently under virtually constant operating pressure; the fluctuations of pressure are very small.

Vessels for this type of load are not marked in a particular way and may be used as long as the vessel inspections, carried out regularly, do not uncover any safety-relevant deficiencies.

We recommend that aluminium vessels should be exchanged after 15 years at the latest.

Vessels for dynamic load:

These pressure vessels may also be used under conditions of changing operating pressure. The pressure may vary between the atmospheric and the maximum admissible operating pressure.

The pressure vessel documentation and the appropriate notes in the operating manual particularly characterise vessels of this type as being adequate for dynamic loads. In the technical information for these vessels you will find specifications concerning their permissible operating period.

Due to the variation of the operating pressure, these vessels are subject to a so-called dynamic load, which puts the vessels under great stress. The change between two different pressures is called a load change or cycle. In the technical information for these vessels you will find specifications concerning the permissible number of cycles depending on the fluctuation of the operating pressure.

Having reached half the permissible number of cycles, the vessel has to be submitted to an internal check, in which

the critically stressed areas of the vessels are examined by means of suitable testing methods, in order to ensure the operating safety.

After having reached the total permissible number of load cycles, the vessel must be exchanged and scrapped. Record the number of load cycles in writing if you do not have an automatic cycle-counter.

We recommend that aluminium vessels should be exchanged after 15 years at the latest.

Please pay attention to and follow these measures, for your own safety and that of you employees and customers!

In order not to unnecessarily load the pressure vessels additionally, the non-return valves, that are meant to avoid a drop in pressure, and also the pressure maintaining valves, which should reduce big pressure fluctuations as well, should be checked regularly for internal and external tightness and functionality.

- Check the pressure vessels regularly on the inside and outside for damage from corrosion.
- Be particularly careful with second-hand pressure vessels, when their previous operating mode is not specifically clarified.

2.4. SAFETY REGULATIONS (EC; partly Germany, only)

A compressor is identified by German law as being a filling system if pressure cylinders are filled by the system, especially when these cylinders are made available for third parties. The start-up and operation of compressor systems for use as filling stations is governed by the following regulations:

Pressure vessel directive (Directive 97/23/EC) of 29.05.1997

Operating safety regulations (BetrSichV) of 27.09.2002

Machine safety law (GSG) of 11.05.2001

14th regulation to machine safety law (14. GSGV - pressure vessel regulation) of 03.10.2002

Technical regulations for pressure gases (TRG 400, 401, 402, 730).

If a high pressure compressor is used for filling pressure vessels or for the supply of pneumatic systems, the following regulations apply:

Accident Prevention Regulations (UVV):

BGV A1 of 01. January 2004

Copies of the above regulations are available through the usual outlets, e.g. in Germany from:

Carl Heymanns Verlag
Luxemburger Str. 449
50939 Köln

Beuth-Vertrieb GmbH
Burggrafenstr. 4 - 7
10787 Berlin

The manufacturer has complied with all applicable regulations and the unit is prepared accordingly. If desired, we offer at our Munich site a partial acceptance test according to § 14 BetrSichV. Please contact our Technical Service Department with regard to this. They can also supply our leaflet **"IMPORTANT NOTES FOR CERTIFICATION"**.

According to the operation safety regulations (BetrSichV), all compressor units which will be used as filling stations must undergo an acceptance test by a professional at their location before bringing them into service. If pressure vessels (bottles) are to be filled by the compressor for a third party then the appropriate permission must be obtained from the responsible authority before the acceptance test. As a rule, this is the factory inspectorate. The procedure for obtaining permission is according to TRG 730, guidelines for permission to set up and operate filling stations. The test certificates and documents delivered with the compressor are important and may be requested during the procedure for obtaining permission. In addition, the documents belonging to the unit are important for recurrent inspections and should therefore be carefully kept.

Inspections in accordance with the regulations for prevention of accidents will be carried out by the manufacturer or by a specialist.

No guarantees whatsoever are valid for damage caused or favoured by the non-consideration of these directions for use.

We strongly emphasize these regulations.

3. LOCATION, OPERATION, BOTTLE FILLING

LOCATION

Outdoor location



The compressor unit is not seawater resistant. At operation in salty air spray compressor with anticorrosive protection (e. g. Quicksilver Corrosion Guard). Electric driven units should be operated and stored below deck. Units with petrol engine should also be stored below deck after the filling process.



Keep unit away from inflammable items. Do not smoke while petrol tank is open and while unit is in operation.

- Locate the unit level.
- On units with petrol engine it is most important that only clean air be used, position compressor in direction of wind so that exhaust fumes are blown away from the unit.
- Turn unit as soon as wind direction changes.
- Take care that no vehicles are in direct vicinity with engines running.
- Do not operate unit in the vicinity of open fire (flue gas!).

Indoor location



Petrol driven units must not be operated indoors.

- Ensure adequate ventilation.
- Here too, air must be free from exhaust fumes and hazardous vapours (e.g. smoke, solvent vapours, etc.).
- If possible install unit in such a manner that the compressor fan can get fresh air from outside, for instance through an opening in the wall.
- Ensure that an adequate exhaust air opening is provided.
- When locating the compressor in small rooms where natural ventilation is not ensured, measures must be taken to provide artificial ventilation (this also applies when other systems having high radiation are operating in the same room).

Electrical installation

For installation of electrical equipment observe the following:

- Comply with regulations of local electricity supply company.
- Arrange for the electrics to be connected by an electrician only.
- Ensure correct installation of protective conductor.

- Check conformity of motor tension and frequency with those of electric network.
- Operate electric units only on mains sockets equipped with fault current circuit breaker according to DIN VDE 0664 with a nominal differential current of less than 30 mA (up to 16 A in single-phase AC circuits).
- For units not connected through a plug, but permanently installed, a main switch must be provided which has a contact gap of minimum 3 mm on each pole.
- Fuse motor correctly; use slow-blow fuses, only.
- Immediately after start-up check direction of rotation for agreement with arrow on unit.



If power supply cable is to be replaced, use cable of same type, only!

- When using extension leads or cable drums, operate unit with unwound cable, only to avoid overheating and risk of fire. The maximum length for extension cables at normal ambient temperatures (approx. 20 °C) is 25 metres.

OPERATION

Preparation for operation



All compressor units are tested prior to delivery to the customer, so after correct installation of the unit there should be no problem putting it into operation, observing the following points:

CAUTION The compressors described in this manual are not suitable for compression of oxygen. EXPLOSION occurs if an oil lubricated compressor is operated with pure oxygen or gases with an oxygen content of more than 21%!

- Prior to first operation read Instruction Manual carefully. Make sure that all persons handling the compressor and the filling station are familiar with the function of all controls and monitors. Particularly observe chapter 2 **SAFETY REGULATIONS**.
- After taking unit into operation after a standstill period of 2 years or more change compressor oil. When using a mineral oil change oil after one year.
- Prior to **first** operation or operation subsequent to repair work operate unit for at least 5 minutes with open condensate valves (pressureless) to ensure proper lubrication of all parts before pressure is built up.
- Prior to **each** operation check the oil level according to chapter 4.4.1. and determine whether maintenance is necessary in accordance with chapter 4.3.
- Every time the unit is started up check all systems for proper operation. If any malfunction is observed stop unit immediately and find the cause of the fault or call the service department.

Units with three phase current motor, additionally:

- Immediately after switching on the system for the first time check the direction of rotation of the motor for compliance with the arrow on the unit. If motor turns in the wrong direction, the phases are not connected properly. Shut down unit immediately and interchange two of the three phase leads in the switch box. Never change leads at the motor terminal board.

Units with petrol engine, additionally:

- Check engine oil level according to manufacturer's instruction manual.
- Check fuel tank. Top up if necessary.
- Open fuel shut-off valve.

Starting the unit

- Open condensate drain valves on the filters to release pressure so that motor starts without load.

Units with electric drive motor:

- **Three-phase current:** the motor is switched on manually by turning the switch (1, Abb. 6) to 1.



Abb. 6 Motor protection switches (three-phase motor)

- **Alternating current:** Set 0-I switch to I.

Units with petrol engine:

- Set choke to position START. Start engine with recoil starter or crank handle. As soon as motor runs smoothly return choke to normal operating position.

All units:

- Close condensate drain valves and run unit to final pressure. Check final pressure safety valve and pressure gauge.
- As soon as final pressure is reached and final pressure safety valve blows off, open condensate drain valves and drain condensate - unit is ready for filling operation. Observe regular condensate drain acc. to chapter "Maintenance".

FILLING PROCEDURE

General

CAUTION

Ensure intake air is free from noxious gas (CO), exhaust fumes and solvent vapour. On units employing petrol or diesel engine it is most important to use an intake hose and observe that only clean air is drawn in. The intake hose is also recommended for units with electric engine. When operating the unit in areas with possibly high CO contents, the CO removal filter cartridge is recommended for electric driven units, also. Note that for CO contents of more than 25 ppmV in the intake air the allowed limits cannot be guaranteed even with a CO removal filter cartridge, resulting in a life-threatening CO concentration! Also, due to chemical reaction of CO with hopcalite, warming up of the cartridge and danger of fire may result.

CAUTION

Filling hoses must be in satisfactory condition and threads undamaged. Pay particular attention to damage on the interface from hose fitting to hose. If the casing is scored, hose must be discarded.

The filling valve connection is of the manual type and permits connection to air tanks without using tools. An O-ring is provided for self-sealing due to internal overpressure. Compressed air tank filling valves for a pressure in excess of 200 bar are standardized (DIN 477, sheet 5) and connectors for 200 and 300 bar are different and cannot be mixed up. **The use of adapters is not allowed!**

To ensure safe air tank removal after filling, the valve has an integral venting bore. Therefore always close tank valve first before closing filling valve. During filling procedure bottles will warm up due to recompression. After removing, allow to cool down, bottles may then be reconnected and topped up to the respective maximum filling pressure.

CAUTION

To meet the CO₂ maximum rating value in breathing air bottles, please observe the two following chapters "Intake air quality" and "Scavenging the compressor unit".

Intake air quality

At routine tests, CO₂ values beyond the permissible values are noted from time to time. Closer investigations often show that the compressed air is taken from rooms in which one or more persons are working. At insufficient ventilation, the CO₂ value in the surrounding air can increase quite fast because of the exhaling of CO₂. CO₂ values from 1,000 to 5,000 ppmv in workrooms are not unusual (MAK-value (max. workroom concentration) is 5,000 ppmv). Another additional increase is caused by cigarette smoking, producing approx. 2g CO₂ (≈ 2,000 ppmv) per cigarette. These pollutions add up to the basic pollution of approx. 400 ppmv. The technically caused excessive increase of CO₂ during the filling process and the CO₂ peak at taking the unit into operation. **Because of the reasons stated above and for your own security, the filling of breathing air bottles is not allowed in rooms used as workrooms.**

Scavenging the compressor unit

CO₂ is present in the atmosphere with a natural amount of 350 to 400 ppm_v. The molecular sieve used in the purifier for drying the breathing air is, as well as other capabilities, able to adsorb CO₂ which is accumulated in the cartridge. After shut-down of the compressor, adsorbed CO₂ may be desorbed again due to the partial pressure decrease. The now free CO₂ then gets washed out of the cartridge when the compressor is started again. To avoid increased CO₂ contents in the compressed breathing air, we recommend to flush the compressor unit 1 to 2 minutes prior to connecting the bottles, i.e. to let the air escape into the surroundings.

Connecting the bottles



On models of 300 bar rated filling pressure do not attach bottles unless rated for this pressure (note pressure stamped on tank neck).

- Connect air bottle to filling valve (see Abb. 7).
- Air bottles with international filling connector can be connected with filling adaptor (part no. 79375) to the German filling connector (see Abb. 8).



The international connector is not permitted in the Federal Republic of Germany. In other countries it is allowed only for pressures up to 200 bar (2,850 psi).

Filling the bottles

- Open filling valve (1, Abb. 9).
- Open bottle valve (2) - bottle will be filled. Drain condensate regularly during filling. On units with automatic condensate drain check that condensate is drained regularly.



The filling procedure should not be interrupted for more than 10 minutes to avoid increased CO₂-values in the air filled into the bottles.



Abb. 7 Connecting air bottle



Abb. 8 International filling connector



Abb. 9 Filling air bottle

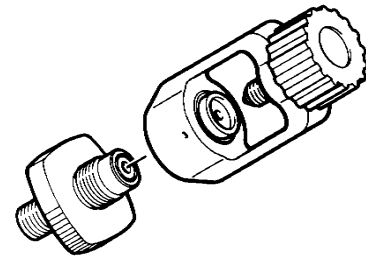

Abb. 10 Removing air bottle

Removing the bottles

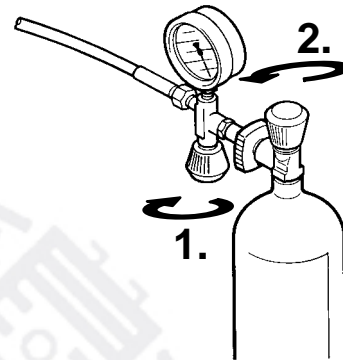
- Upon reaching final bottle pressure **close bottle valve first** (1, Abb. 10), **then filling valve** by returning handle to closed position (2).
- Remove compressed air bottle.

CHANGE-OVER DEVICE PN 300/PN 200

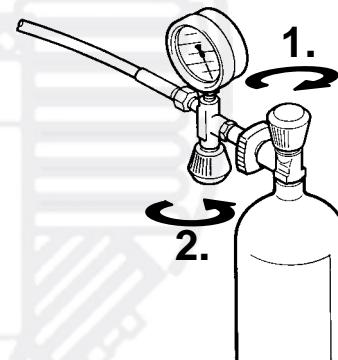
(Abb. 11) This device allows bottle filling to 200 bar (3,200 psig) with a 300 bar (4,700 psig) rated unit. Safety valve -B and filling device PN 200 bar are connected by opening change-over valve -A and the connected bottles can be filled with a 200 bar pressure, as described in "Filling the bottles".



Depressurize unit before opening valve -A to avoid damage to the change-over device

SHUT-DOWN PROCEDURE

- Close filling valve.

Units with electric motor:

- **Three-phase current:** the motor is switched off by turning the switch (1, Abb. 12) to 0.
- **Alternating current:** set 0 - I switch to 0.

Units with petrol engine:

- Shut down petrol engine with stop button or stop lever.

All units:

- Drain condensate from intermediate separator and Triplex filter by means of the drain taps. Vent unit by means of filling valve to approx. 80 bar (1,150 psi). Close all valves again to prevent moisture entering the filter and resulting saturation of the cartridge.
- Check the oil level in the compressor and top up, if necessary. Also check whether the compressor needs servicing in accordance with maintenance schedule - see chapter 4.3.



Abb. 11 Change-over device



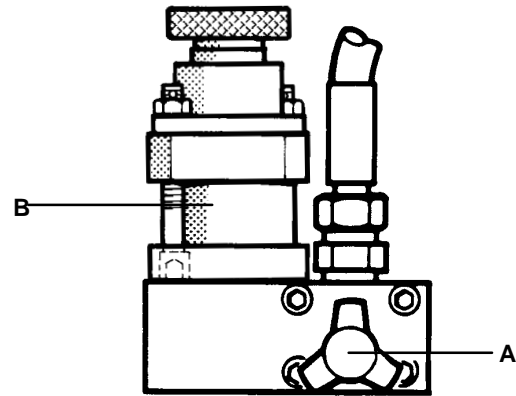

Abb. 12 Motor protection switches (three-phase motor)

B-TIMER (optional)

Introduction

Read operating instructions carefully before operating the unit.

 **The settings in the setup menu are essential for the correct indication of the filter capacity. Without correct settings, the B-Timer can be used as an hourmeter, only!**

 **Make sure that the pressure maintaining valve of the compressor is adjusted to 150 bar (factory setting, see chapter 4.4.5.) and is working properly to ensure correct indication of the filter capacity and compressor operation recognition.**

Description

The **B-Timer** (Abb. 13) is a self-activating mini-computer that counts the operating hours of the compressor and calculates the saturation of the filter cartridge from time, temperature, cartridge type, and delivery rate of the compressor. It displays operating hours, cartridge lifetime, and all maintenance due for the compressor. The **B-Timer** does neither need external power nor any other connection to the pressure system. It is simply fastened to the filter housing which has to be monitored, by means of a clamp, and is therefore the ideal filter control device for all mobile compressor units, especially for portable petrol or diesel driven scuba diving models. In addition, the B-Timer can be mounted easily to any unit as an upgrade device.

Authorized use

This unit is to be used exclusively as operating status monitoring device and does not release the user from additional surveillance and testing of the breathing air quality of the filter system according to national standards (e.g. EN 12021). With the **B-Timer**, this is **not** possible!

The **B-Timer** may only be used with the filter systems P21, P31 and P41. The respective filter cartridge numbers are stored in the software. Other use is strictly prohibited. The manufacturer and the supplier void all responsibility for risk, damage or injury resulting from failure to follow these instructions.

Please observe the operating limits of the unit:

- Operating temperature range 0° C to +50 °C,
- Storage temperature -20° C bis +70 °C
- Protection class IP65 (Protection against contact with wire, dust, and jet of water)
- Vibration ±3g in operation
- max. 95% humidity, not condensating

Function

The B-Timer display shows the following functions:

- Operating hours of the compressor unit
- Cartridge lifetime in % by means of four segments in the cartridge symbol.
- Flashing last segment and change from operating hours indication to cartridge part no. if capacity is equal or less than 20% of the original lifetime.
- Indication of compressor maintenance due by means of letter symbols and operating hours.



Abb. 13 B-Timer

- 1 Key symbol (maintenance due)
- 2 Letter symbol (maintenance type)
- 3 Low battery symbol
- 4 Cartridge saturation indicator
- 5 Operating hours or cartridge number
- 6 Mode select key
- 7 Enter key

A = 500 hours or 1 year
 B = 1000 hours or 1 year
 C = 2000 hours or 2 years

- Battery symbol indicating that the lithium battery is low and has to be changed. **All data are stored and will not be lost when changing battery.**

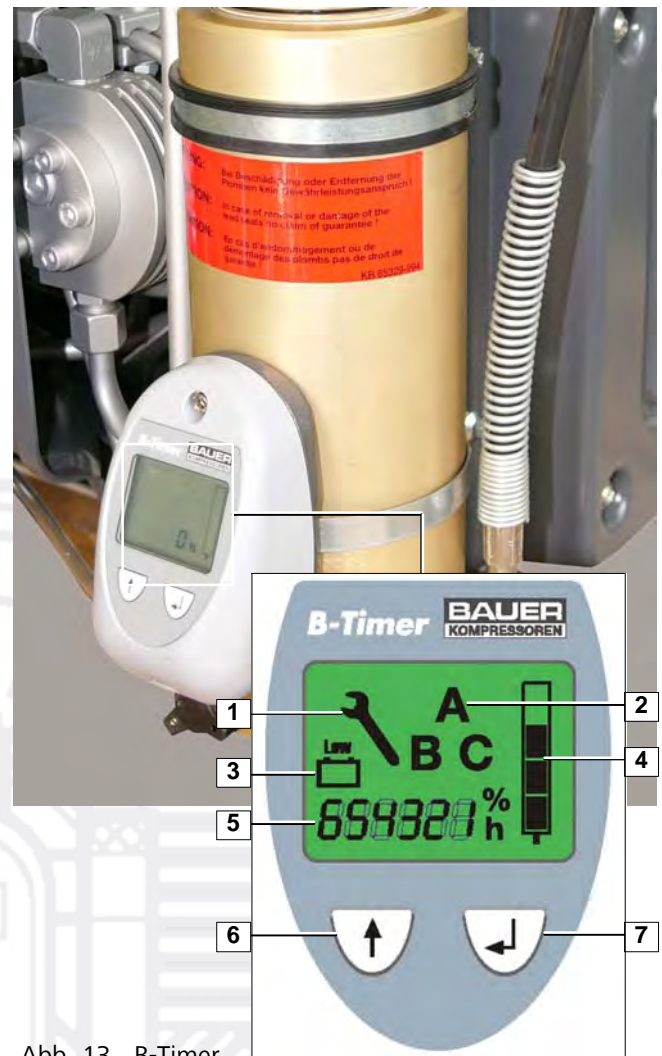
The **B-Timer** is operated using the mode select and the enter keys.

Error indication

If the temperature sensor in the unit should be defective, an error message "Error 1" or "Error 2" is shown at the display (Abb. 14). In this case the unit should not be used but sent to the factory or the nearest BAUER representative for repair.

Battery change

The battery (1, Abb. 15) is merely inserted into the holder.

To change the battery remove two bolts and separate housing from base plate. Remove plug (2) and pull out battery.

Make sure to use the same type battery (BAUER part no. 82743).



Abb. 14



Abb. 15 Battery

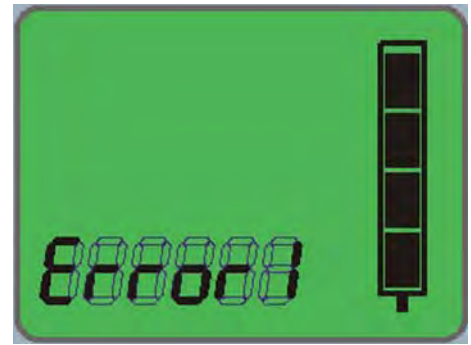

Abb. 16



Abb. 17

Operation

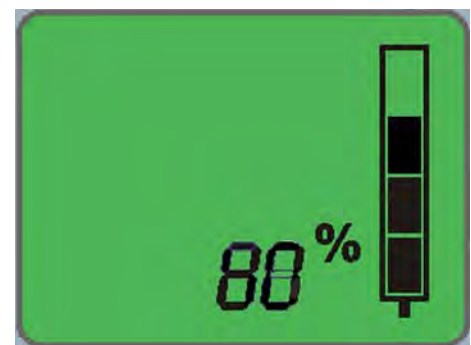

The B-Timer is activated when starting the compressor. Compressor operation is indicated by the flashing "h" symbol.

To switch on the B-Timer press one of the keys on the display. Main menu will be displayed (Abb. 16).



If no key is pressed within 1 minute, the indication will return to the main menu. After 2 minutes the B-Timer is switched off, if no compressor operation is detected.

Abb. 18

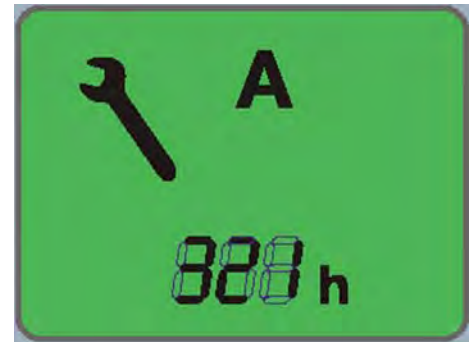

Function Display



To *display* the desired function, press the select key (↑).

Press ↑ key. Remaining filter capacity is shown, Abb. 17)

Abb. 19

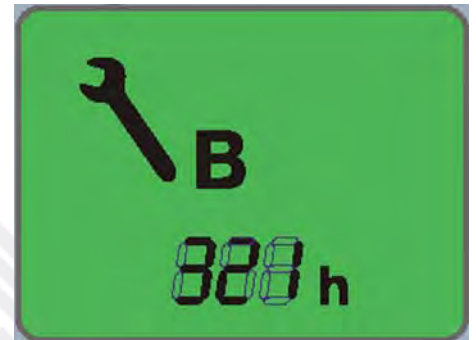

Press ↑ key again. Remaining operating hours to service interval A (500 hours or annually) are shown (Abb. 18).

Press ↑ key again. Remaining operating hours to service interval B (1000 hours or annually) are shown (Abb. 19).

Abb. 20

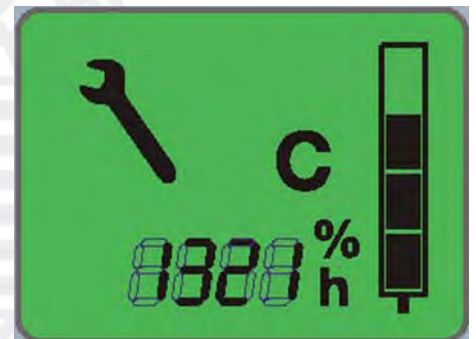

Press ↑ key again. Remaining operating hours to service interval C (2000 hours or biennially) are shown (Abb. 20).

Press ↑ key. Filter cartridge number is shown (Filter symbol flashing, Abb. 21).

Press ↑ key again. Display returns to the main menu.

Abb. 21

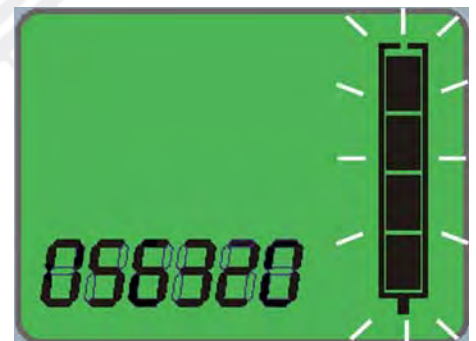

Reset



The filter capacity must not be reset unless a new filter cartridge has been fitted!

To *reset* the filter capacity or the A, B, and C maintenance intervals, press ↓ key for more than 5 seconds from the respective maintenance interval display (Abb. 22).

Abb. 22



Setup

To **enter the setup** for the different functions of the **B-Timer** press the ↑ and ↓ keys on the display simultaneously for more than 5 seconds from the cartridge number display (Abb. 21). Filter symbol starts flashing (Abb. 23) indicating the setup mode.

Under **setup A** the filter cartridge number is set. To change cartridge type, press ↓ key for 3 seconds, the number starts flashing. Press the ↑ key to select the correct number, press ↓ key to accept the new setting.



Numbers beginning with 999 require a special adjustment:

Press ↓ key for 3 seconds. Press the ↑ key to select 999000, the last 0 starts flashing. Press the ↑ key to select the correct number, then press ↓ key: the second 0 will start flashing, proceed as above and finally adjust the 3rd 0 accordingly.

Pressing the ↑ key, display changes to **setup B** for the delivery setting. Filter symbol starts flashing (Abb. 24). To change delivery (in ltrs./min), press ↓ key for 3 seconds, the 1st digit starts flashing. Press the ↑ key to select the correct number, press ↓ key to accept the new setting. Repeat procedure for the other two digits

Pressing the ↑ key again, display changes to **setup C** for the pressure range setting. Filter symbol starts flashing (Abb. 25). To change pressure, press ↓ key for 3 seconds. Press the ↑ key to select the correct pressure (200, 300 or 200/300), press ↓ key to accept the new setting.



After finishing setup and fitting a new cartridge, the filter capacity has absolutely to be reset, see "Reset" above.

Pressing the ↑ key again, display changes to the menu for **adjusting the operating hours**. Press ↓ key for 2 seconds, the last digit will start flashing. Press the ↑ key to select the correct number, then press ↓ key etc., until all digits are set. Then pressing the ↑ key twice will lead back to the main menu, Pressing the the ↑ key and the ↓ key gives the possibility to readjust the hours again, if required.



Abb. 23



Abb. 24

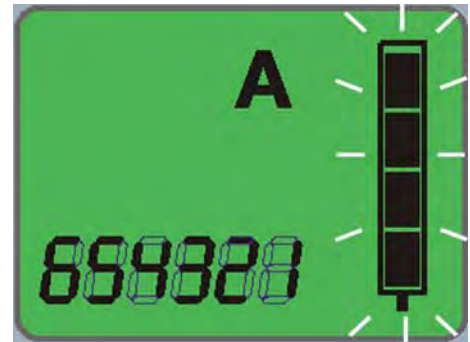

Abb. 25

4. MAINTENANCE

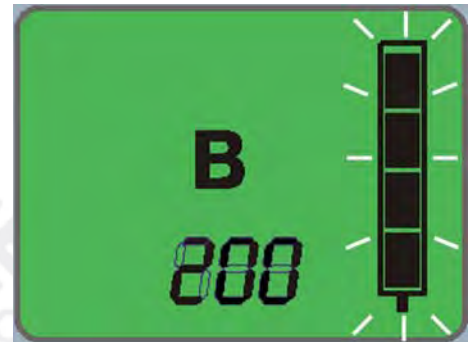
4.1. MAINTENANCE RECORD

We recommend that all maintenance work is recorded in the service book, showing the date and details of the work carried out. This will help to avoid expensive repairwork caused by missed maintenance work. If it is necessary to claim against the warranty, it will help to have proof that regular maintenance work has been carried out and that the damage has not been caused by insufficient maintenance. Please refer to section 23 of our general terms and conditions.

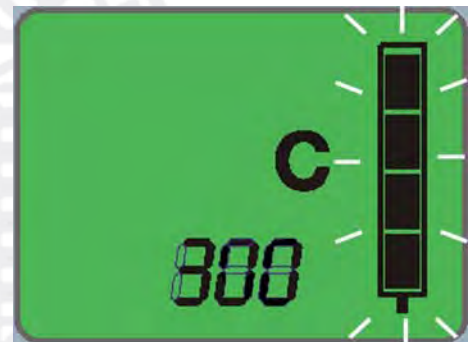
4.2. MAINTENANCE INSTRUCTIONS

CAUTION Always shut down and decompress the complete system prior to carrying out any work on the compressor.

CAUTION Never repair pressure lines by soldering or welding.



Check the complete system for leakage from time to time by brushing all fittings and couplings with soapy water or spraying with leak test spray. Repair any leakage.



Only use original spare parts for maintenance or repair work.



Change TRIPLEX longlife cartridge according to chapter 4.4.4.!



The used cartridge must be disposed of according to local regulations.



Maintenance of drive motor/engine according to manufacturer's operating instructions.

4.3. MAINTENANCE SCHEDULE

The maintenance schedule is contained in the service manual delivered with every compressor unit.

4.4. MAINTENANCE WORK

This chapter contains the maintenance work as well as a short functional description for each component.

4.4.1. LUBRICATION

TYPE OF OIL

For proper care and maintenance of the compressor, using the correct oil is of vital importance. Depending on the application of the compressor the requirements placed on the oil are:

- low deposits
- no carbonizing effect, especially in the valves
- good anti-corrosive properties
- emulsification of the condensate in the crankcase
- physiological and toxicological suitability.

Due to the thermal load on the compressor only high quality oil should be used. You are recommended to restrict oils to those which have been approved by us and are listed in our lubricating oil list.



The current oil list is provided in the annex, chapter 8. Order this list regularly through the BAUER Technical Service Department.

For operation under difficult conditions such as continuous running and/or high ambient temperatures we recommend the use of **BAUER** high performance compressor oils, only, according to the oil list. These oils are tested in our compressors and have proved excellent quality under ambient temperatures between +5 °C (41 °F) and +45 °C (113 °F). For lower temperatures, a heating device is required which is capable of pre-heating the crankcase up to +5 °C (41 °F).

For operation under less severe conditions, for intermittent operation, or operation with long idle periods we can also recommend mineral compressor oils which are suitable for operation under ambient temperatures between +5 °C (41 °F) and +35 °C (95 °F). Here also, pre-heating is required for lower temperatures.

OIL LEVEL CHECK

Check oil level daily prior to putting compressor into operation. Check using oil dipstick.

Take care that dip stick is inserted completely. Note that the oil level must be between minimum and maximum dipstick markings (see Abb. 26).



Oil level must not decrease below min. mark but also not exceed max. mark as this will cause excessive lubrication of compressor and result in valves sooting up.

OIL CHANGE INTERVALS

Mineral oils	every 1,000 operating hours, at least annually
Synthetic oils	every 2,000 operating hours, at least biennially

OIL CAPACITY

Junior II	approx. 360 ml
-----------	----------------

OIL PACKAGES

BAUER compressor oil is available in various quantities, refer to oil list in chapter 8.

OIL CHANGE

- Run compressor warm.
- Remove oil dipstick.
- Drain oil while still warm by means of oil drain plug. Replace the sealing, reinstall drain plug and tighten well.
- Refill with oil through the oil filler neck.
- Oil level is checked with oil dipstick, oil level is correct if at upper mark.



Abb. 26 Oil dipstick markings

CHANGING THE OIL TYPE

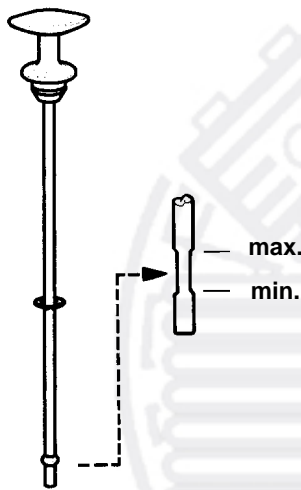

To avoid severe damage to the compressor unit when changing the oil type, the following measures should be strictly adhered to:

- Drain oil completely while still warm.
 - Check valves, coolers, separators, purifiers, and all pneumatic tubes and hoses for deposits.
- If deposits are detected, perform the following:
- Change or clean valves, coolers, separators, purifiers, and all pneumatic tubes and hoses from deposits.
 - Fill compressor with the new oil.
 - After approx. 100 operating hours check lubricating oil for degree of contamination, and change oil again if necessary.
 - Top up compressor and perform subsequent oil changes with same oil, only.

4.4.2. INTAKE FILTER

DESCRIPTION

A dry micron filter is used to filter intake air (Abb. 27).

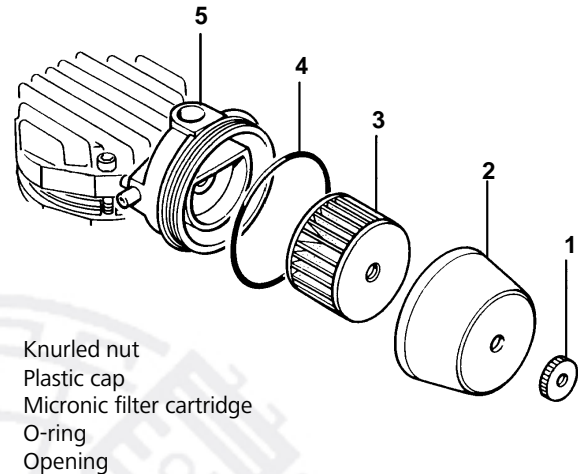

- 1 Knurled nut
- 2 Plastic cap
- 3 Micronic filter cartridge
- 4 O-ring
- 5 Opening

Abb. 27 Intake filter

INTAKE FILTER MAINTENANCE

Filter cartridge must be changed at regular intervals according to schedule in the service booklet.

- Remove knurled nut (1) and take off plastic cap (2). Remove filter cartridge (3).
- Clean filter housing inside with a damp cloth. Take care to prevent dust from entering intake pipe.
- Replace O-ring (4) if damaged.
- Insert a new filter element and fasten with cap and nut.

TELESCOPIC INTAKE TUBE

The telescopic intake tube has to be inserted in opening 5, Abb. 27. It is necessary to ensure clean air. Petrol driven breathing air compressor units are fitted with a telescopic intake tube supplied with the unit. The use of it is also recommended for electric power driven units.

4.4.3. INTERMEDIATE SEPARATOR

DESCRIPTION

An intermediate separator is mounted on the compressor between 2nd and 3rd stage. It is designed to remove water and oil accumulating due to cooling the compressed medium down after the compression process.

Separation is achieved by means of centrifugal action provided by a vortex plate.

INTERMEDIATE SEPARATOR MAINTENANCE

Proper operation will rely on the intermediate separator being properly serviced.

Open drain tap (1, Abb. 28) and drain off condensate every 15 to 30 minutes during operation.



Abb. 28 Condensate drain taps

4.4.4. FILTER SYSTEM P21

DESCRIPTION

The air leaving the final stage is cooled in the after-cooler to approx. 10 - 15 °C (18 - 27 °F) above ambient temperature and then enters filter system **P21** with **TRIPLEX** longlife cartridge (Abb. 29).

The filter assembly consists of separator and cartridge chamber. In the separator surrounding the cartridge chamber liquid oil and water particles are reliably separated from the compressed medium by a pipe nozzle.

Residual oil and water vapors are then removed by the **TRIPLEX** longlife cartridge. The quality of the breathing air produced conforms to DIN EN 12021.

CARTRIDGE SAFETY BORE

The filter system **P21** is designed to prevent pressurizing in the absence of the filter cartridge. A bore provided in the filter bottom is sealed air-tight only if the cartridge is in place (Abb. 30).



No pressure build-up without cartridge!



Abb. 29 Filter system P21

- 1 Filter inlet
- 2 Jet pipe
- 3 Filter head
- 4 Final pressure safety valve
- 5 Housing
- 6 Chamber separator
- 7 Cartridge
- 8 Filter outlet
- 9 Pressure maintaining valve
- 10 Condensate drain tap
- 11 Condensate outlet

Without cartridge the venting bore is not sealed, the air escapes into the atmosphere, no pressure can be built up and thus it is ensured, that unfiltered air is not supplied to the consuming device.

The venting bore is also used to check the O-rings on the cartridge pin. If air is leaking out of the venting bore even though a cartridge is installed, the O-rings are either broken or were damaged on installation.

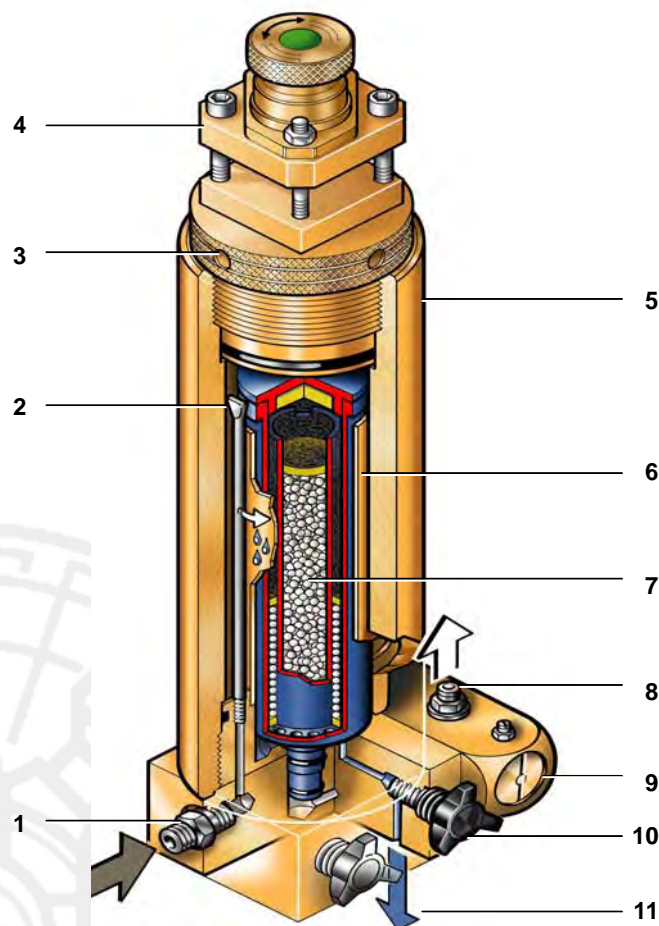
Remove and check cartridge. If necessary replace cartridge or O-rings.



Abb. 30 Safety bore

LIFETIME

CAUTION The filter system is subject to dynamic load. It is designed for a certain number of load cycles, which originate from an abrupt pressure loss at condensate drain (1 load cycle i.e. condensate drain = 1 depressurization, 1 pressurization). The filter housing has to be inspected internally by an expert after having reached 1/4 of the determined number of load cycles. The inspections have to be arranged by the operator. After reaching the max. number of load cycles the filter assembly must be replaced, otherwise the housing may burst due to material fatigue.

The max. number of load cycles for the P21 Central Filter Assembly is **4,000** if operated at the max. allowable pressure difference range of 330 bar (4,700 psi). For a pressure difference of 225 bar (3,200 psi) the max. no. of load cycles is **35,000**.

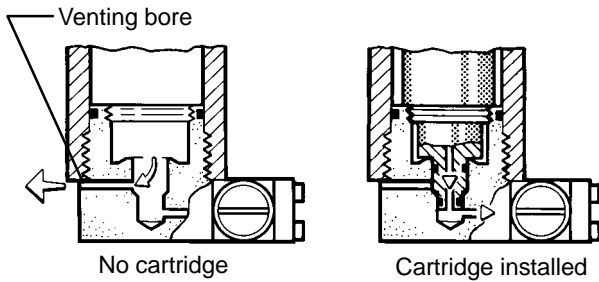
To avoid exceeding the max. number of load cycles the operating hours should be recorded in the service manual. On condition that a max. number of four cycles per hour is not exceeded (condensate is drained every 15 minutes) the max. number of operating hours is **1,000 for 330 bar units**, and **8,750 for 225 bar units**.

GENERAL INSTRUCTIONS FOR FILTER MAINTENANCE

- **Depressurize** system before starting any maintenance work.
- **Dry** inside of filter housing with a clean cloth before installing new cartridge and check for corrosion. Change if necessary.
- **Lubricate** threads and O-rings as well as threaded part of cartridge with white petrolatum DAB 9 order no. N19091 or WEICON WP 300 white order no. N19752.
- **Record** number of pressure bottles and/or operating hours to ensure exact attention to maintenance intervals.
- **Change** cartridge before reactivating a compressor unit after out-of-service periods of more than 3 months.
- **Leave** cartridge in the filter as long as unit is out of service.
- **Keep** all condensate drain valves and taps closed. Keep a minimum pressure of approx. 50 to 80 bar (700 to 1,100 psi) within the system to prevent moisture entering the compressor piping and filter system.

- The nozzle type separator of the **TRIPLEX** filter system is maintenance-free besides the regular condensate drainage.

CONDENSATE DRAINAGE

Drain condensate from separator and cartridge chamber regularly by slowly opening drain taps (2 and 3, Abb. 28)

- before changing cartridge
- before each filling procedure
- during filling procedure every **15 minutes**.

Slowly open left tap first, then right tap approx. 1/3 turn to the left, until condensate is completely drained. The taps close by spring pressure, if necessary tighten by hand to make sure they are completely air-tight.

FILTER CARTRIDGES

New filter cartridges are vacuum-packed and can be stored for two years (refer to date on the cartridge). A defective vacuum package cannot protect the cartridge appropriately against environmental influences during storage. Should the package be damaged, do not use the cartridge.

To avoid any danger to your health or damage to your unit, change used up cartridges in good time.

Never fill used up cartridges yourself! The filter material was chosen specifically by BAUER-KOMPRESSOREN for each kind of application.

Pay attention to cleanliness and hygiene when changing the filter.

FILTER SERVICE LIFETIME

The average weight (without package) of a new cartridge and the increase in weight can be checked with appropriate weighing scales. Due to inevitable production tolerances, there may be small differences compared to the given data.

The number of operating hours or the amount of possible bottle fillings per filter cartridge can be determined by the tables on page 22 and 23 taking into consideration the ambient temperature and the cartridge used.

These tables contain calculated cartridge lifetime data, that refer to defined and constant operating conditions. Tolerances at bottle fillings and different operating temperatures can lead to considerable divergences compared to data given, which therefore can only serve as reference values for the user.

Cartridge 057679 is the normal TRIPLEX-cartridge for electric units.

Filling weight: 191 g; Saturation weight 205 g.

Example: at an ambient temperature of 20°C, 36 to 45 10-ltr-bottles can be filled with a TRIPLEX-cartridge, which is equivalent to 12 to 15 compressor operating hours at a filling pressure of 200 bar.

On compressor units with petrol engines only use **cartridge, part no. 059183 to dry, de-oil and remove CO.**

Filling weight: 217 g; Saturation weight 229 g.

Example: at an ambient temperature of 20°C, 31 to 38 10-ltr-bottles can be filled with this cartridge, which is equiv-

alent to between 10 and 13 operating hours at a filling pressure of 200 bar.



The longer service life of the cartridge at a filling pressure of 300 bar is annihilated by the larger volume of filled air per bottle, therefore the possible number of bottle fillings stays the same at different pressures.

CARTRIDGE CHANGE



For safety reasons only CO removal cartridges part no. 059183 should be used on compressor units with petrol engine. On units with electric engine either CO removal cartridge part no. 059183 or TRIPLEX cartridge part no. 057679 can be used.



Units with petrol engine are delivered with CO removal cartridge part no. 059183 as standard, units with electric engine with TRIPLEX cartridge part no. 057679. When changing from electric engine to a petrol engine also replace cartridge part no. 057679 with cartridge part no. 059183.



Never remove replacement cartridge from packaging prior to actual use otherwise highly sensitive molecular sieve will absorb water vapour from surrounding air and cartridge saturated and thus be ruined.

- Prior to changing the filter cartridge, drain condensate and depressurize filter system completely by opening condensate drain valves.
- Remove filter head (3, Abb. 29).
- Extract old cartridge and insert a new one.
- Screw in filter head to the stop without use of force.



The used cartridge must be disposed of according to local regulations.

FILLING VALVE MAINTENANCE

To protect filling valve against contamination a sintered metal filter is screwed in the filling valve body.

Remove filter insert and clean, if heavily soiled replace, as follows (refer to maintenance schedule, 4.3.):

- Unscrew pressure gauge from filling valve body.
- Screw off sintered metal filter with a suitable screw driver.
- To clean filter element, the best method is to use hot soapy water and to blow dry with compressed air. Replace if heavily soiled.
- Screw in filter element,.
- Seal pressure gauge with PTFE tape or Loctite 243 and screw in tight to desired position.

1. Filter cartridge 057679: lifetime [hours]		
Filling pressure p = 200 bar		Junior II
Ambient temperature tU [°C]	Final separator temperature tAb [°C]	Delivery Q [l/min]
		100
10	20 - 24	26 - 21
15	25 - 29	20 - 16
20	30 - 34	15 - 12
25	35 - 39	11 - 9
30	40 - 44	9 - 7
35	45 - 49	7 - 6
40	50 - 54	5 - 5
Filling pressure p = 300 bar		Junior II
Ambient temperature tU [°C]	Final separator temperature tAb [°C]	Delivery Q [l/min]
		100
10	20 - 24	39 - 31
15	25 - 29	29 - 24
20	30 - 34	22 - 18
25	35 - 39	17 - 14
30	40 - 44	13 - 11
35	45 - 49	10 - 9
40	50 - 54	8 - 7

Filter cartridge 057679: bottle fillings [number] Molecular sieve mass mMS [g] = 68							
Ambient temperature tU [°C]	Final separator temperature tAb [°C]	Air humidity, saturated X [g/m ³]	Processable air volume Va [m ³] at pressure p [bar]		Number of bottle fillings n acc. to bottle size		
			200	300	7 l	10 l	12 l
10	20 - 24	17,31 - 21,80	157 - 125	236 - 187	112 - 89	79 - 62	65 - 52
15	25 - 29	23,07 - 28,79	118 - 94	177 - 142	84 - 67	59 - 47	49 - 39
20	30 - 34	30,40 - 37,63	89 - 72	134 - 108	64 - 52	45 - 36	37 - 30
25	35 - 39	39,65 - 48,64	69 - 56	103 - 84	49 - 40	34 - 28	29 - 23
30	40 - 44	51,21 - 62,41	53 - 44	80 - 65	38 - 31	27 - 22	22 - 18
35	45 - 49	65,52 - 79,28	42 - 34	62 - 51	30 - 25	21 - 17	17 - 14
40	50 - 54	83,08 - 99,85	33 - 27	49 - 41	23 - 19	16 - 14	14 - 11

Bottle volume VF [m ³]		
Bottle size	at pressure p [bar]	
l [ltr.]	200	300
7	1,4	2,1
10	2	3
12	2,4	3,6

Number of bottle fillings n =
 processable air volume / bottle volume = Va / VF

Bottle volume: VF [m³] = p [bar] x l [l] / 1000 [l/m³]

Processable air volume: Va [m³] = 0,2 x mMS [g] / (X [g/m³] / p [bar]) = 0,2 x p [bar] x mMS [g] / X [g/m³]

Filter cartridge lifetime: tp [h] = Va [m³] / (Q [m³/min] x 60 [min/h])

2. Filter cartridge 059183: lifetime [hours]		
Filling pressure p = 200 bar		Junior II
Ambient temperature tU [°C]	Final separator temperature tAb [°C]	Delivery Q [l/min]
		100
10	20 - 24	22 - 18
15	25 - 29	17 - 13
20	30 - 34	13 - 10
25	35 - 39	10 - 8
30	40 - 44	8 - 6
35	45 - 49	6 - 5
40	50 - 54	5 - 4
Filling pressure p = 300 bar		Junior II
Ambient temperature tU [°C]	Final separator temperature tAb [°C]	Delivery Q [l/min]
		100
10	20 - 24	34 - 27
15	25 - 29	25 - 20
20	30 - 34	19 - 15
25	35 - 39	15 - 12
30	40 - 44	11 - 9
35	45 - 49	9 - 7
40	50 - 54	7 - 6

Filter cartridge 059183: bottle fillings [number] molecular sieve mass mMS [g] = 58							
Ambient temperature tU [°C]	Final separator temperature tAb [°C]	Air humidity, saturated X [g/m ³]	processable air volume Va [m ³] at pressure p [bar]		Number of bottle fillings n acc. to bottle size		
			200	300	7 l	10 l	12 l
10	20 - 24	17,31 - 21,80	134 - 106	201 - 160	96 - 76	67 - 53	56 - 44
15	25 - 29	23,07 - 28,79	101 - 81	151 - 121	72 - 58	50 - 40	42 - 34
20	30 - 34	30,40 - 37,63	76 - 62	114 - 92	55 - 44	38 - 31	32 - 26
25	35 - 39	39,65 - 48,64	59 - 48	88 - 72	42 - 34	29 - 24	24 - 20
30	40 - 44	51,21 - 62,41	45 - 37	68 - 56	32 - 27	23 - 19	19 - 15
35	45 - 49	65,52 - 79,28	35 - 29	53 - 44	25 - 21	18 - 15	15 - 12
40	50 - 54	83,08 - 99,85	28 - 23	42 - 35	20 - 17	14 - 12	12 - 10

Bottle volume VF [m ³]		
Bottle size	at pressure p [bar]	
l [litr.]	200	300
7	1,4	2,1
10	2	3
12	2,4	3,6

Processable air volume: $V_a [m^3] = 0,2 \times mMS [g] / (X [g/m^3] / p [bar]) = 0,2 \times p [bar] \times mMS [g] / X [g/m^3]$

Filter cartridge lifetime: $t_p [h] = V_a [m^3] / (Q [m^3/min] \times 60 [min/h])$

Number of bottle fillings n =
processable air volume / bottle volume = V_a / VF
Bottle volume: $VF [m^3] = p [bar] \times l [l] / 1000 [l/m^3]$

4.4.5. PRESSURE MAINTAINING VALVE

DESCRIPTION

A pressure maintaining valve is mounted at the outlet of the filter system P21.

It ensures that pressure is built up in the filter even from the start of delivery, thus achieving a constant, optimum filtration. It will also guarantee proper working conditions for the final stage cylinder.

The pressure maintaining valve is adjusted to **150 ±10 bar (2,175 psi)**.





Abb. 31 Pressure maintaining valve

MAINTENANCE

The pressure maintaining valve (Abb. 31) is adjusted at the factory to the required pressure and normally does not require regular maintenance or readjustment. In case of readjustment becoming necessary, loosen jam nut (2) and set screw (3). Adjust screw (1) to the required pressure using a suitable screw-driver.

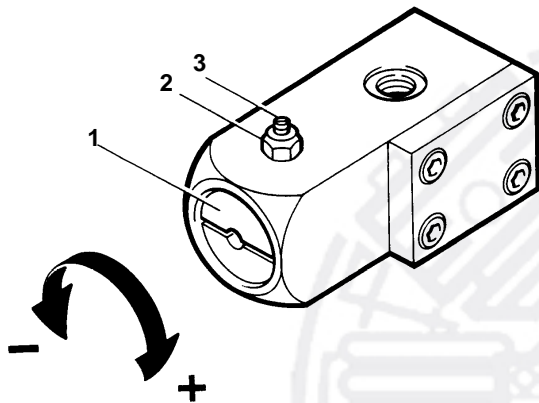
 **Clockwise = increase pressure**
Counter-clockwise = decrease pressure

4.4.6. SAFETY VALVES

DESCRIPTION

All three compressor stages are protected by safety valves as follows

1st stage 9 bar (130 psi)
2nd stage 80 bar (1,160 psi)

The safety valve for protection of the last stage is mounted on top of the filter system P21 and is adjusted to the operating pressure of the unit (see chapter 1, Technical Data), **225 bar (3,200 psi)** for the standard units, **330 bar (4,700 psi)** for models -H or -HU. All safety valves are sealed at the factory.

If one of the intermediate pressure safety valves blows off, the valves in the next stage are not closing properly, affording valve check. The cause of the trouble is usually the inlet valve of the next stage. See also chapter 4.4.8.

MAINTENANCE

Checking function

The final pressure safety valve has to be checked regularly. For this purpose the safety valve can be vented manually. Turn knurled knob on top of the valve clockwise until valve blows off (Abb. 32).

This just ensures that the valve is functional and will release pressure in case of a malfunction. To check the blow-off pressure value refer to "Blow-off pressure check".



Abb. 32 Venting the final pressure safety valve

Checking blow-off pressure

Check blow-off pressure of the final pressure safety valve regularly, see maintenance schedule chapter 4.3. Pump unit to final pressure with shut-off valve closed until safety valve blows off. Check blow-off pressure of safety valve at pressure gauge. If deviation is 10% or more, replace safety valve.

4.4.7. PRESSURE GAUGE

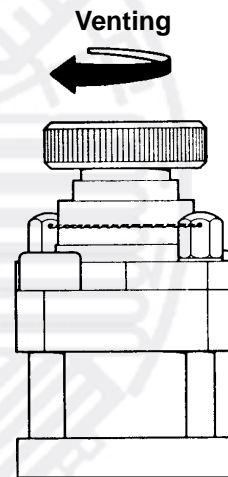
DESCRIPTION

The compressor unit is equipped with a final pressure gauge (Abb. 33). The red marking on it shows the max. allowable operating pressure.



Abb. 33 Final pressure gauge



Abb. 34 Valve operation

MAINTENANCE

We recommend that the final pressure gauge is checked from time to time. For this purpose we have developed a special test pressure gauge with an adaptor which immediately recognizes any deviations in readings (see High Pressure Accessories Catalogue 8550/..).

Slight deviations during operation are normal and can be ignored. Excessive inaccuracy will require the pressure gauge to be replaced.

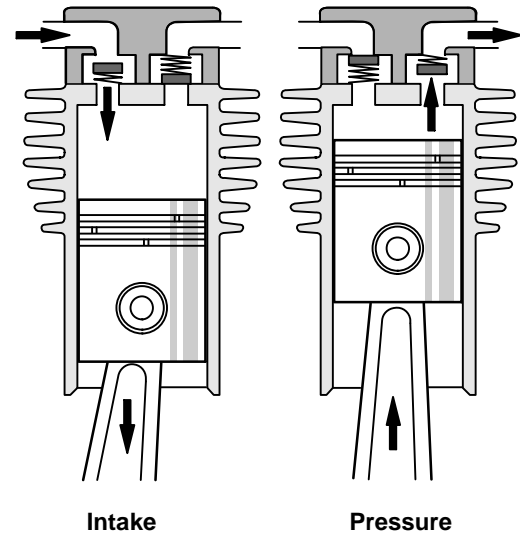
4.4.8. VALVES

DESCRIPTION

The valve heads of the individual stages form the top part of the cylinders. The intake and pressure valves are fitted inside the valve heads. Note that the valves are operated by the flow of the air.

On the suction stroke, the intake valves open and the air flows into the cylinders. At the start of the compression stroke the intake valve closes and the air opens the pressure valve, Abb. 34.

Intake and pressure valve of the 1st stage is a plate valve (Abb. 35).

INITIAL OPERATIONAL CHECK

After maintenance work on the valves, valves should be checked. Note that the intake line to the valve heads should be warm and outlet piping should be hot. Valves are then operating properly.



Abb. 35 Valve 1st stage

GENERAL INSTRUCTIONS FOR CHANGING THE VALVES

- **Always replace** valves as a complete set.
- **Observe** the correct sequence when fitting together again.
- **Check** individual components for excessive wear. If the valve seat and valve disks are dented, replace the valves.
- **Valve head screws** must be tightened with a torque wrench (see tightening torque values chapter 7.).
- **Check** the valve space in the valve heads for dirt and clean, if necessary.
- **30 minutes after restarting** the compressor stop unit, let it cool down to ambient temperature and retighten valve studs and cap nuts. Otherwise valves could work loose due to setting of the gaskets.
- **Use only** satisfactory gaskets and O-rings on reassembly.
- **After finishing** all maintenance work on the valves, turn the compressor manually using the flywheel and check whether all items have been correctly installed.

CHANGING THE VALVES OF THE 1ST STAGE

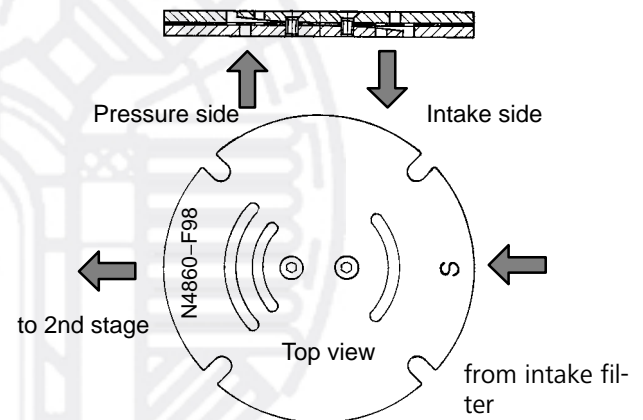
Intake and pressure valves of the 1st stage are combined in one plate valve under the valve head, see Abb. 36.



Abb. 36 Valve head 1st stage

- Loosen two cap nuts from tube connectors at valve head and safety valve connector and remove inter-cooler.
- Remove four valve head screws (5) from valve head (1). Take off valve head.
- Remove gasket (2) and plate valve (3).
- When re-installing the valve, check that mark "S" is facing upwards and towards intake filter side. The crossbar of gasket (2) seals the intake opening with respect to the two outlet openings of the pressure valve.

CHANGING THE VALVES OF THE 2ND STAGE

Both, pressure and intake valves can be serviced from outside, see Abb. 37.

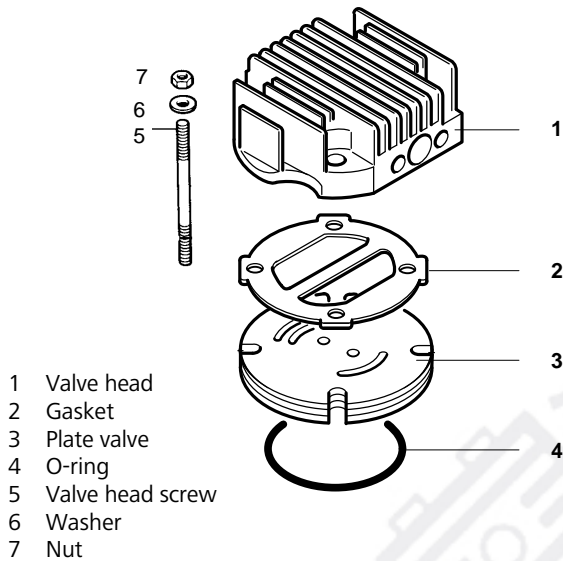
- Remove two captive nuts (1) and spring-washers (2).
- Remove plate (3).
- Remove valves (4) and (7) using two screw-drivers as shown in Abb. 39.
- Assemble in reverse sequence. Position spring-washers with curved side facing upwards. Fasten nuts so that plate (3) is parallel to the valve head. Torque with 10 Nm (1 kpm).



Abb. 37 Valve head 2nd stage

CHANGING THE VALVES OF THE 3RD STAGE

On this valve head, the valves are arranged on the upper and lower side due to the small diameter of the 3rd stage, see Abb. 38.

For removal and installation of the intake valve (4) use special tool which is also part of the tool set delivered with the unit. Pressure valve (3) is merely inserted into valve head (5). It is sealed by O-ring (2) and fixed to the valve head by bolt (1).

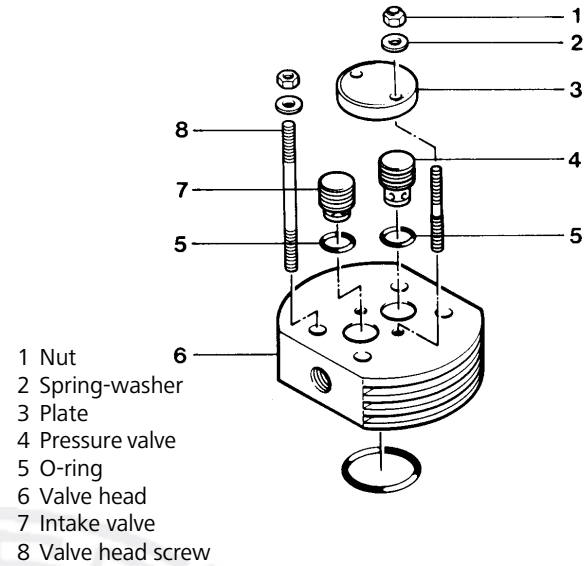

Abb. 38 Valve head 3rd stage

Change intake and pressure valve of 3rd stage together only.

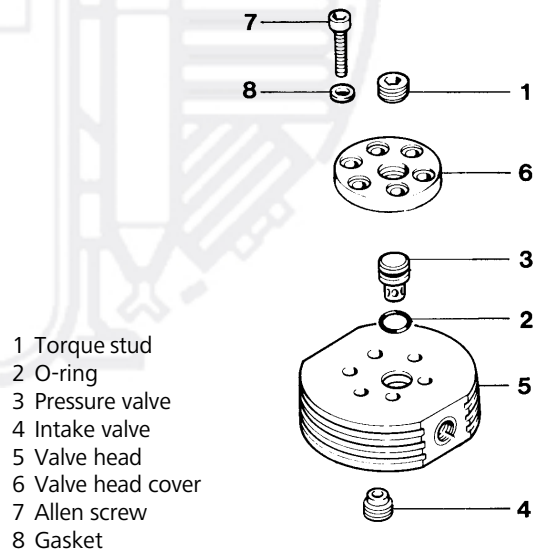

- Remove 3rd stage pressure valve (3) according to Abb. 38.
- Unwind torque stud (1) a couple of turns.

- Remove allen screws (7), take off valve head cover (6).
- Put two screwdrivers into the groove of pressure valve body (Abb. 39). If necessary turn valve loose at first using a 13 mm spanner on the flat surfaces.
- Lift out pressure valve (3) together with O-ring (2).

Reinstall pressure valve (3) in reverse sequence:

- Check O-ring for abrasion and replace if necessary. Put O-ring (2) into valve head (5).
- Insert pressure valve (3). Install valve head cover (6).
- Fasten valve head with allen screws (7) and washers (8).
- Screw in torque stud (1) with 20 Nm (2 kpm).



Abb. 39 Removal of 3rd stage pressure valve

4.4.9. COMPRESSOR DRIVE SYSTEM

DESCRIPTION

The compressor is driven by the drive motor through a V-belt. The motor is mounted on the base plate and requires adjustment for proper V-belt tension.

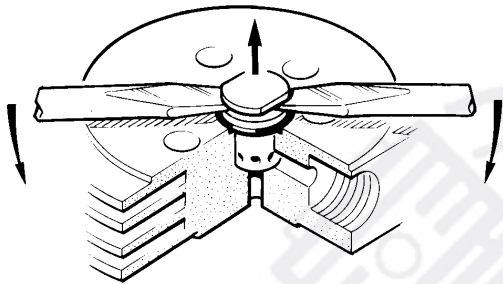

Improper v-belt tension and adjustment of the pulleys will result in extreme v-belt abrasion and premature wear.

MAINTENANCE

Checking the drive belt tension

- The best tension for a belt drive is the lowest possible, where the belt under full load does not slip. A rough value for this is when the belt deflects **10 mm** when pressed with thumb pressure between the two pulleys (Abb. 40). For best results we recommend our v-belt tension meter, part no. N25238.

V-belt tension adjustment

- Slightly loosen motor mounting nuts
- Adjust motor until the belt tension is correct (see Abb. 40).
- Tighten motor mounting nuts.
- Run motor for approx. 5 minutes. Stop motor, check V-belt tension, and readjust if required.

- Check that after tension adjustment and tightening the motor mounting nuts, both pulleys are in a straight line to avoid excessive wear of the V-belt. Hold a straight edge against compressor and motor V-belt pulleys as shown in Abb. 41: edge must be parallel to the v-belt.



Abb. 40 Checking V-belt tension



Abb. 41 V-belt pulley adjustment

4.4.10. ELECTRICAL SYSTEM

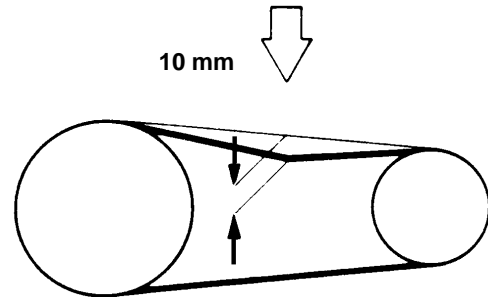
DESCRIPTION

This section describes the standard electrical system.

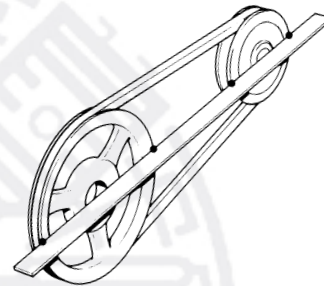

For schematic diagram, see annex.

The electrical equipment of the compressor unit consists of:

- drive motor
- electric control system

To start the electric motor and enable the functioning of the electric control, the following components are essential:

- main switch and main fuse, both to be installed by the customer.

DRIVE MOTOR

The compressor unit is driven by an alternating or a three phase current motor by means of a V-belt.

MOTOR PROTECTION SWITCH (ALTERNATING CURRENT MOTOR)

Protection of the motor is ensured by the thermic releases integrated into the motor protection switch (1, Abb. 42). The response value is preset. The motor is switched on manually by pressing the 0-I switch to I. For safety of the operating personnel all voltage carrying parts have a protective cover.

MOTOR PROTECTION SWITCH (THREE-PHASE MOTOR)

The motor is switched on manually by turning the switch to 1 (Abb. 43). It is switched off manually by turning the switch to 0.

For safety of the operating personnel all voltage carrying parts have a protective cover.



After the switch has shut off by overcurrent triggering, the motor can be restarted by pressing the start-button not before the bi-metal in the switch has cooled down. This may last a couple of minutes.

Protection of the motor is ensured by the thermomagnetic releases integrated into the motor protection switch. The response value of the electromagnetic releases (protection against short-circuit) is preset.

MAINTENANCE

For the electrical system no regular maintenance is required.

4.4.11. COOLING SYSTEM

The cylinders of the compressor block, the intermediate coolers and the after-cooler are air-cooled.

For this purpose, the compressor is equipped with a fan-wheel connected to the counter-weight at the crankshaft end opposite to the V-belt pulley. It draws the cooling air through the fanwheel cover from the surroundings.

Refer to chapter 3. for proper installation and cooling air supply. For maximum ambient temperature, see Technical Data, chapter 1.



Abb. 42 Motor protection switch (alternating current)



Abb. 43 Motor protection switch (three-phase motor)

4.5. TROUBLE-SHOOTING

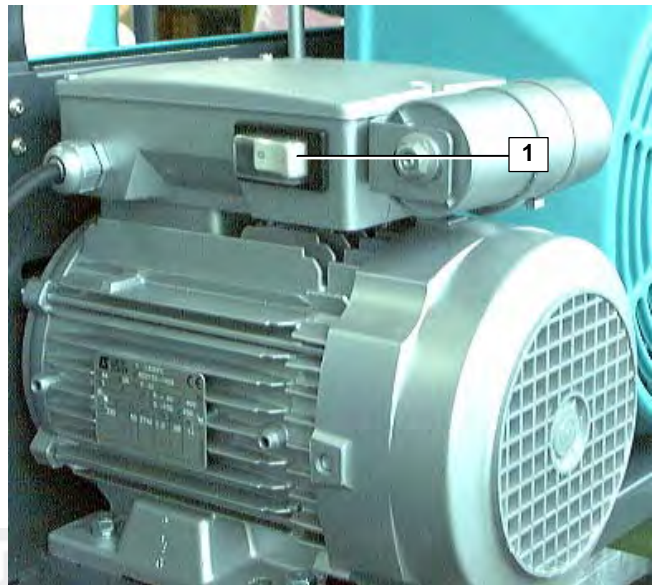
Trouble	Cause	Remedy
Drive motor (electric)		
Motor will not start	Electric circuitry faulty	Check all fuses, terminal connections, wire leads, make sure that motor data complies with mains supply
Motor/engine runs eccentrically	V-belt worn	Replace
Motor protection switch is switching off the unit	Wrong adjustment of the motor protection switch	Set to nominal motor current. Observe temperature compensation (+20 °C =1,0) For ambient temperature + 10 °C : correction factor 0,94 + 30 °C : correction factor 1,05 + 40 °C : correction factor 1,12
	Uninsufficient voltage because of weak power supply	Switch off other consuming devices
Motor protection switch is switching off the unit	Power supply cable too long or too thin	Use suitable cable
Drive motor (petrol)		
Motor will not start	See motor instructions	See motor instructions
Motor runs eccentrically	V-belt worn	Replace
Motor stops	Low oil level	Top up oil
Drive system		
Excessive v-belt wear (black deposits on belt guard)	V-belt tension	Re-tighten, see chapter 4.4.9.
	Pulleys not aligned	Re-adjust, see chapter 4.4.9.
Compressor		
Compressor does not attain final pressure	Condensate drain valve(s) leaking	Tighten and reseal
	Final pressure safety valve defective (blows too soon)	Replace safety valve
	No cartridge in filter system P21 (air escaping through cartridge safety bore)	Replace cartridge
	Vent screw for final pressure safety valve not in operating position	To vent, unscrew until completely open
Air delivery drops	Intake filter soiled	Clean or replace filter cartridge
	Pipe coupling leaking	Retighten couplings
	Excessive wear of 3rd stage piston	Replace piston and sleeve of 3rd stage
Intermediate pressure safety valve blows	Intermediate pressure too high because of defective inlet or pressure valve of the following stage	Check/replace inlet or pressure valve
	Safety valve leaking	Replace safety valve
Compressor overheats	Insufficient cooling air	Check location; ensure proper cooling air flow
	Ambient temperature too high	Check location; ambient temperature max. +45 °C (113 °F)
	Direction of rotation is wrong	Correct direction of rotation
	Inlet and pressure valve of one stage is leaking	Check valves, clean/replace if necessary
Taste of oil in the air	TRIPLEX cartridge saturated	Replace cartridge
	Unqualified lubricant being used	Replace oil with an approved brand

Trouble	Cause	Remedy
High oil consumption	Piston rings, Pistons or cylinders worn out	Replace defective parts
	Intake filter clogged	Replace filter cartridge
	Compressor too hot	Enhance cooling
Air escaping through cartridge safety bore	Cartridge missing	Insert cartridge
	Cartridge installed but O-rings defective	Check/replace O-rings

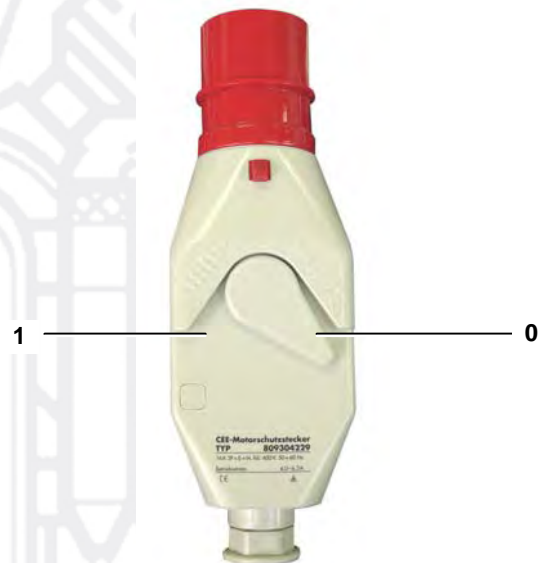

5. STORAGE, PRESERVATION

GENERAL

If the compressor is put out of service for more than six months, the unit should be preserved in accordance with the following instructions: Make sure the compressor is kept indoors in a dry, dust free room. Only cover the compressor with plastic if it is certain that no condensation will form under the sheet. Nevertheless, the sheet should be removed from time to time and the unit cleaned on the outside. If this procedure cannot be followed and/or the compressor is going to be taken out of service for more than 2 years, please contact our Technical Service Department for special instructions.



The compressor is not resistant to salt-water! If not in use keep unit in a dry place.

PREPARATION

Before preserving the compressor unit, run it warm and when it reaches the specified service pressure, keep it running for approx. 10 minutes.

Then carry out the following:

- Check all pipes, filters and valves (also safety valves) for leakage.
- Tighten all couplings, as required.
- After 10 minutes, open the filling valves or the outlet valve and run the compressor at the set minimum pressure (pressure maintaining valve, see chapter 4.4.5.) for approx. 5 minutes.
- After these 5 minutes, shut the system down. Drain condensate from separators. Depressurize unit. Shut filling valves.
- Open filters and grease threads.
- **Ensure that filter cartridge remains in the filter!** This will prevent oil entering filling lines as a result of preservation procedures.
- Remove intake filter from manifold and all intake lines from valve heads.
- Let compressor unit cool down.

PRESERVING THE COMPRESSOR

- Turn the compressor on and spray a small amount (approx. 10 ccm/0.6 cu. in.) of compressor oil into the valve head inlet port while the compressor is running. Do not let the compressor warm up too much, to keep oil sticky.
- Shut compressor unit off.
- Close all valves.
- Place the dust cap onto the inlet port.

PRESERVING THE MOTOR/ENGINE

Preserve the motor/engine according to the instructions of the motor/engine manufacturer.

PREVENTIVE MAINTENANCE DURING STORAGE

Run the compressor **once every 6 months** as described in the following:

- Remove the dust cap from the inlet port and insert the intake filter.
- Open the filling valves or the outlet valve and let the unit run for approx. 10 minutes or until the pressure gauges indicate the correct values.
- Stop the compressor.
- Open condensate drain valves and release compressed air. Close condensate drain valves again.
- Carry out preservation procedure according to chapter "preserving the compressor"

Changing the lube oil for preserving

- After prolonged storage, the oil will age in the compressor and engine. It should be drained after **2 years** at the latest and replaced with fresh oil.
- The stated period can only be attained when the crankcase is sealed during the preservation period in accordance with the preservation requirements.
- After changing the oil, turn the compressor and the engine or run them for the required period.
- Check the lubrication of the compressor when putting the unit into operation once every six months or when turning the compressor. The oil pump is functioning properly when oil can be seen flowing through the sight glass of the oil pressure regulator and if the oil pressure gauge indicates the prescribed pressure.

REACTIVATING THE COMPRESSOR UNIT

- Remove the dust cap from the inlet port and insert the intake filter.
- Check the oil level of the compressor.
- Check the motor/engine according to the manufacturer's instructions.
- Open the purifier and change all filter cartridges.
- Run the compressor warm with open filling valves or outlet valve for approx. 10 minutes.
- Check the oil pressure on the pressure gauge. If there is any fault, check the lubrication of the compressor.
- After 10 minutes, close the filling valves or the outlet valve and run the unit up to final pressure until the final pressure safety valve blows.
- Check the inter-pressure safety valves for leakage.
- Establish cause of any fault from the trouble-shooting table, chapter 4.5., and take corrective action.
- Stop the system when running properly, the compressor is then ready for operation.

6. REPAIR INSTRUCTIONS

GENERAL

Preventive maintenance usually involves replacing the valves, gaskets and sealing rings as well as carrying out the maintenance work. Repair work can be carried out on the compressor block to a certain extent but a certain experience and skill is necessary. It should be noted, however, that

- no repair should be carried out on the crankdrive nor on the bearings
- safety valves are not repaired but always replaced completely.

For many **BAUER** compressor units, workshop manuals are available through our customer service.

For questions on maintenance and repair, please contact our technical service department.



7. TABLES

TIGHTENING TORQUE VALUES



Unless otherwise specified in text, the following torque values apply. All valve head screws require torque wrench tightening! The indicated torque values are valid for bolts in greased condition. Replace self-retaining nuts on reassembly.

Bolt or screw	Thread	max. torque
Hex and allen head	M 6	10 Nm (7 ft.lbs)
Hex and allen head	M 8*	25 Nm* (18 ft.lbs)
Hex and allen head	M 10	45 Nm (32 ft.lbs)
Hex and allen head	M 12	75 Nm (53 ft.lbs)
Hex and allen head	M 14	120 Nm (85 ft.lbs)
Hex and allen head	M 16	200 Nm (141 ft.lbs)
Pipe connections (swivel nuts):		Finger-tight + 1/2 turn

TORQUE SEQUENCE

Tighten valve head and cylinder bolts/nuts equally in the sequence shown in Abb. 44.

Be sure to tighten all parts in **cold** condition only.



Abb. 44 Torque sequence

* Exception: mounting bolts of final pressure safety valve: 10 Nm

LUBRICATION CHART

Usage	Lubricants
Rubber and plastic parts, filter housing threads	WEICON WP 300 WHITE part no. N19752 or BAUER special grease part no. 072500
Sealing rings	BAUER special grease part no. 072500
Shaft seal (seal) Shaft seal (shaft)	BAUER special grease part no. 072500 Klüber SK 01-205
Screws, bolts, threads	WEICON ANTI-SEIZE AS 040 P part no. N19753 or equivalent compound with copper or MoS ₂ additives

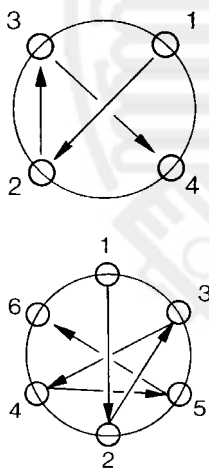
For compressor lubricating oils refer to oil list in chapter 8.

ADHESIVE AND SEALANT CHART

Usage	Adhesives and Sealants
Screws	Loctite 2701
Seals for conical threads	Loctite 243
Metal - metal seals High temperature connections, e.g. valve heads, cylinders	Temperature resistant compound, e.g. WACKER E10, part no. N18247
Paper gaskets	Loctite FAG 2

TESTING AGENTS

Usage	Testing agents
Tube connectors, tubes	Leakage test spray, part no. FM0089

8. ANNEX

- Schematic diagram
Lubricating oil list
Parts list





Schematic diagram motor protection switch, three phase current

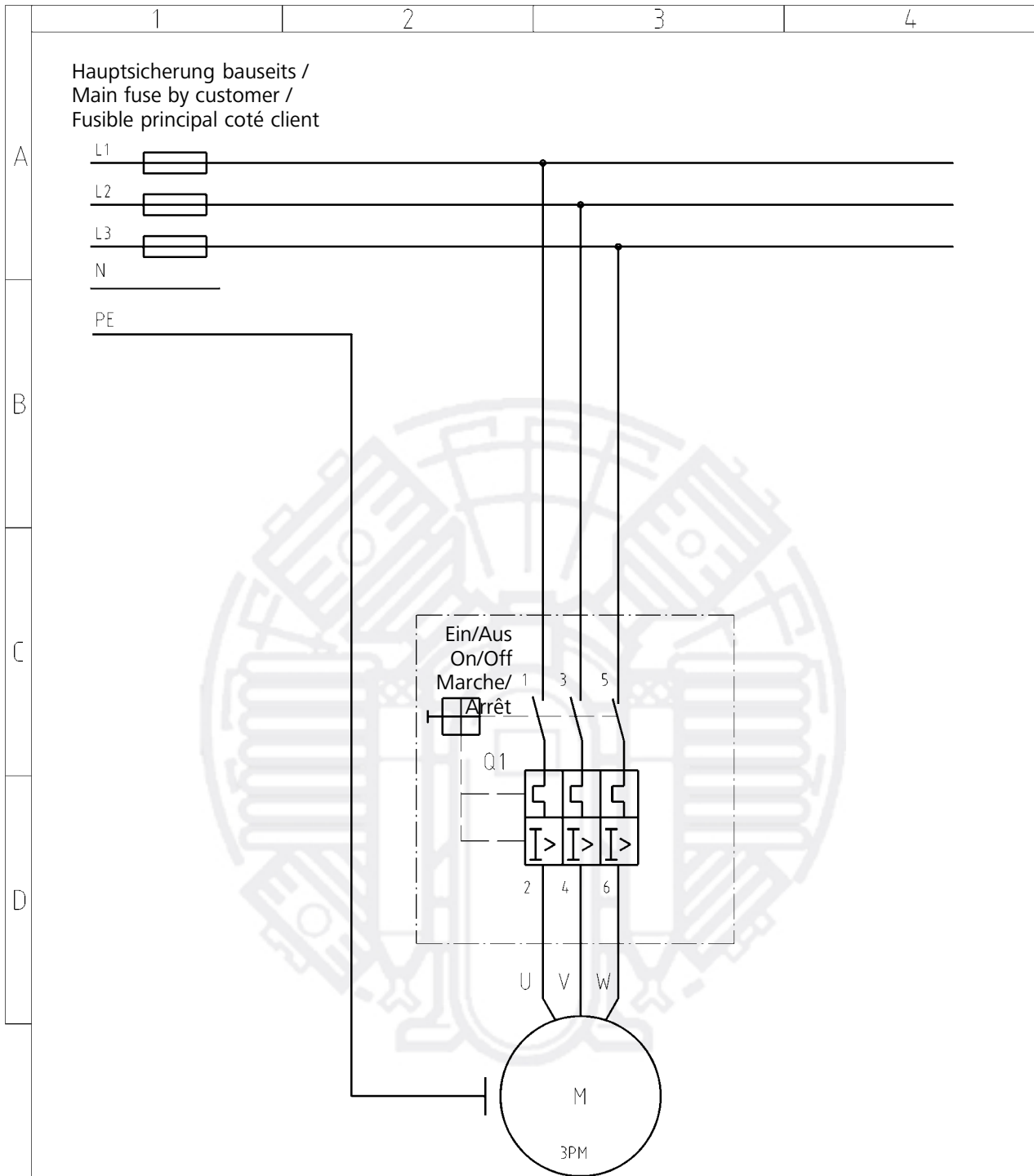

Für diese techn. Unterlage wird jeglicher gesetzlich vorgesehene Rechtsschutz nach DIN 34 in Anspruch genommen.				zul. Abw. ISO 2768 mH	Oberfläche DIN ISO 1302	Massstab: 1:1 Werkstoff:	Masse:
				Datum	Name	Schaltplan/Schematic diagram/Schéma électrique	
			Gez.	13.06.2002	SCHWARZ	Motorschutzschalter	
			Gep.	13.06.2002	SCHWARZ	Motor protection switch	
			Freig.	13.06.2002	EDBCUSTO	Disjoncteur	
BAUER KOMPRESSOREN						Zeichnungs-Nr.	76942-S1
Zust.	Änderung	Datum	Name				Blatt 0





Oil list • Breathing air compressors

GENERAL

After extensive tests with many different kinds of lubricants, we have decided to authorize the following brands of oil for use in **BAUER** compressors under the given operating conditions.

This list is up to date at the time of printing and will be reviewed continuously. Should your list or your instruction manual be older, please request the latest edition from **BAUER** Customer Services. When using any of the oils listed below, please follow the oil change intervals and the oil filling level described for the equivalent **BAUER** compressor oil in the instruction manual of your unit.

Oil type			Use		Ambient temperature
Brand name	Designation	Type	A Breathing air	N Nitrox	+5 ...+45 °C
	Special Compressor oil Part no. N28355 b) c)	S	+	+	+
	Special Compressor oil Part no. N22138 a)	M	+	-	+

Oil type

S	synthetic oil
M	mineral oil

Application

A	approved for breathing air application with BAUER air purification systems
N	approved for nitrox application (with BAUER membrane unit, only)
a)	oil change every 1000 operating hours
b)	oil change every 2000 operating hours
c)	oil change every 1000 operating hours in case of nitrox application

Suitability

+	= suitable
-	= not suitable

TYPE OF OIL

Due to the thermal load on the compressor only high quality oil should be used. You are recommended to restrict oils to those which have been approved by us and are listed in the instruction manual or in the lubricating list on page 1.

Our compressor units are delivered ex works with lubricating oil filled into the crankcase or as consignment, depending on the model, as follows:

Breathing air compressor units:	BAUER Special Compressor oil, part no. N28355
Nitrox compressor units:	BAUER Special Compressor oil, part no. N28355

For operation under difficult conditions, such as continuous running and/or high ambient temperatures, we only recommend the BAUER special synthetic compressor oils acc. to the list on the previous page. These have proved excellent quality under ambient temperatures between +5 °C and +45 °C. For lower temperatures a compressor heating device is required which is capable of pre-heating the unit up to +5 °C.

For operation under less severe conditions, and for intermittent operation, i.e. when the compressor is not used for longer periods between the operating periods, we also recommend the use of the mineral oil acc. to the list on the previous page. This oil is suitable for ambient temperatures between +5 °C and +45 °C. Here also, a pre-heating device will be required if ambient temperatures should fall below +5 °C.

Changing the Oil Type



To avoid severe damage to the compressor unit when changing to another oil type, the following measures should be strictly adhered to.

- Drain mineral oil while still warm.
- Check valves, coolers, separators, purifiers and all pneumatic tubes and hoses for deposits.

If deposits are present, perform the following steps:

- Remove deposits or change valves, coolers, separators, purifiers and all pneumatic tubes and hoses.
- Change oil filter, if applicable.
- Fill compressor with the new oil.
- After approx. 100 operating hours, replace oil filter again (if applicable). and change oil.
- Top up with same oil type.

OIL CHANGE

Mineral oil	every 1000 operating hours, at least annually
Synthetic oil	every 2000 operating hours, at least every two years
Oil change volume	see compressor unit operating manual

BAUER compressor oil is available in the following quantities:

Oil quantity ▼ Oil type ▶	Synthetic oil N28355	Mineral oil N22138
0.5 ltr. bottle	part no. N28355-0,5	part no. N22138-0,5
1 ltr. bottle	part no. N28355-1	part no. N22138-1
5 ltr. container	part no. N28355-5	part no. N22138-5
20 ltr. container	part no. N28355-20	part no. N22138-20