

CE IE3

MADE IN ITALY



INDUSTRIAL range



MICRO - PLUS

Belt-driven oil-injected rotary screw compressors



Fixed and Variable Speed
2.2-75 kW

۱۳۶۲
جهان کمپرسور

Company Profile

FINI boasts more than 70 years of experience and is one of the most important global organisations in the professional and industrial compressed air sector. Synonymous with quality and professionalism, the Fini brand not only provides one of the most comprehensive ranges in the field of rotary air compressors, but above all Fini is now established as a global reference point in terms of quality and technology recognised throughout the industrial compressed air sector.



All Fini industrial compressors are **MADE IN ITALY** and are designed for heavy duty use and distinguished by offering unique and advanced technologies that provides energy saving solutions that work!

► Our compressors offer the ideal solution to the needs of larger-scale industry as well as smaller and mid-sized companies, where compressed air is a most important source of energy.

Fini Screw Compressors are designed for continuous duty in the most arduous operating conditions, with a special attention to reducing energy consumption, lowering operating and maintenance costs along with offering simple installation and ease of use.

► The entire production process, from project design and research through to packaging of the final product is carried out at our facilities in Italy.

Our highly skilled work force are dedicated to supporting the manufacturing and assembling activities. The continuous control and monitoring of each manufacturing process grants the utmost precision at every step, in order to achieve the highest quality, supreme product reliability and flexibility of use.

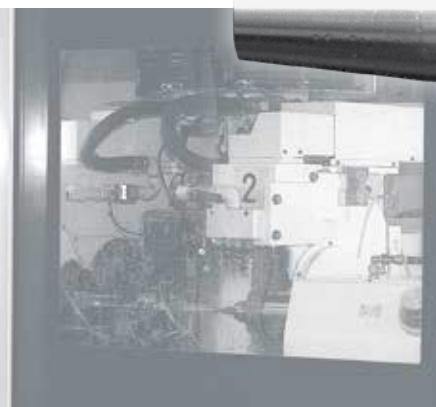
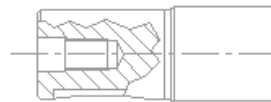

Innovation, Quality and Know-how

Our engineering philosophy is based on the selection and highly controlled assembly of the most reliable and efficient technical solutions. The constant pursuit of excellence in quality along with an innovative spirit and particular attention to the customers demands, are the values that have always characterised FINI and its products.



► The continuous investment in technical design and product innovation has allowed FINI to take a further step forward in the sector, with the launch of the latest range of industrial air compressors- **MICRO and PLUS Series: oil-injected belt-driven rotary screw compressors**, in an extensive range from 2.2 kW to 75 kW.

► During production all of the assembly and testing of products is performed on automated assembly lines that utilise the latest robotic systems. The use of the most advanced and modern machine tools in manufacturing coupled with the employment of advanced controls and processes have been a major focus for the Company representing a very significant investment in order to create products that exceed the quality standards demanded by the market.

Since 1996, the Company has certified its quality systems in compliance with UNI EN ISO 9001.

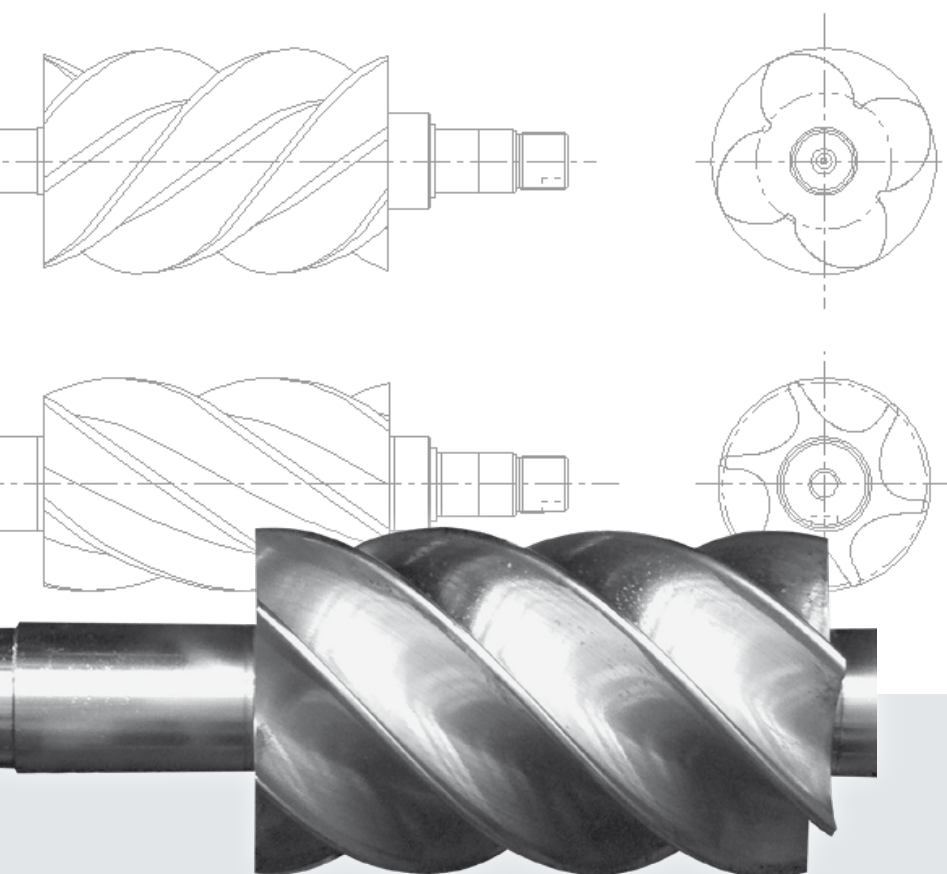

Our TARGET: Maximum efficiency, lower energy consumption and total convenience.

The new belt-driven oil injected Micro and Plus screw compressors have been designed to minimise energy costs, without sacrificing performance. The modularity and flexibility of these products provide multiple solutions suitable for different user's requirements: with or without air receiver, with or without refrigerated dryer, in fixed speed or variable speed formats.



Why you should choose a Fini SCREW compressor?

- ▶ To control and reduce operating costs.
- ▶ To provide the most modern, compact, robust, reliable and quiet rotary screw compressor.
- ▶ To provide a continuous source compressed air.
- ▶ To increase operational efficiency in all areas where compressed air is used.
- ▶ To save energy and reduce CO₂ emissions.

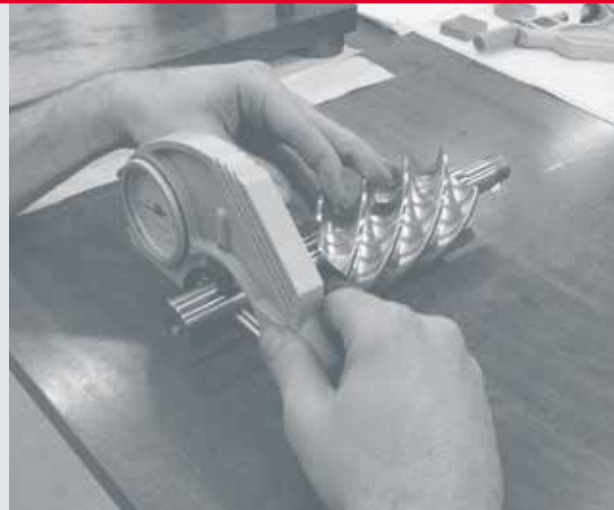

High energy saving

The choice of high quality components, combined with our high performance air-ends and **Premium Efficiency IE3 motors**, ensure reduced power consumption, substantial energy savings and exceptional performance. Furthermore, the IE3 motors reduce CO₂ emissions: an important contribution to protecting the environment.

Plug&Play

Micro and Plus compressors are thoroughly tested at our factories to ensure they are ready for immediate use following delivery, thereby saving time and cutting installation costs.



Low noise level

Micro and Plus compressors are very quiet: the use of very efficient soundproofing materials means that they are suitable for installation in any working environment.



High reliability

The use of premium components from primary global manufacturers along with our advanced assembly with strict quality control and testing, results in a final product that offers a long service life with maximum reliability and fewer maintenance interventions.



High efficiency

Higher air output performance is a key focus for the renowned FINI project engineering and design team. The new Micro and Plus series follows this tradition by offering premium performance levels across the entire range.



Very compact design

The very compact design enables Micro and Plus compressors to be installed close to the application reducing installation costs and improving efficiency.

Our air-ends, inverters and controllers are covered by **2 YEARS WARRANTY**



AIR-END



CONTROLLER

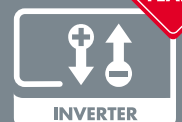

INVERTER



40 dB(A)



62 dB(A)



only 58 dB(A)

COMPETITORS



66-77 dB(A)



100 dB(A)



120 dB(A)

Designed to offer a long service life



1 Innovative cooling system

The cooling system is among the most innovative in the field. A thermostatic controlled centrifugal fan keeps the temperature of the entire compressor to specific tolerance and at a constant level, avoiding temperature peaks that can be harmful for the correct operation of the compressor. The action of the fan, combined with the efficiency of the oversized oil cooler, guarantees the ideal operation of the compressor in differing and even extreme climatic conditions.

The "silent" fans along with the specially developed labyrinth ventilation and the use of high quality soundproofing materials ensure one of the lowest acoustic levels of any air compressor.

2 Efficient transmission

The POLY-V belt drive ensures significantly lower power losses and three times longer service life compared to standard range "V" type belts fitted to other compressors on the market. simple belt tensioning is carried out through a sliding belt tensioner.

3 High performance flexible tubing

All air-oil circuit flexi-tubes are of premium quality and made of multi layer rubber covered with a metal mesh which are resistant to very high temperatures and capable of operation at high pressure.

4 Intake valve

The intake valve is entirely designed and manufactured at our facilities. This most important device, adjusts the compressor's operation to guarantee minimum pressure during idle running and maximum savings upon start-up.

5 Pressure transducer

The use of a digital transducer guarantees an accurate and stable function during operation. It allows direct modification of the working pressure from the electronic controller without any mechanical intervention.



Noise and temperature under control

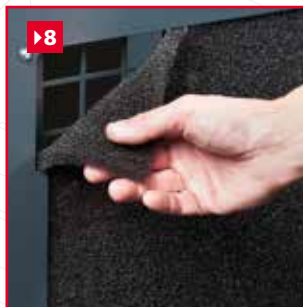

►10 High performance ROTARY SCREW AIR-ENDS

The Fini FS air ends are entirely designed, produced and tested at our Italian facilities: the special design of the screw profile ensures high performance, low temperature and reduced energy consumption.

►6 SPIN-ON filters

Routine service parts that are easy to remove and replace offering long service intervals for lower maintenance costs.

Air filters

Protecting the compressor the oversized filter mass with double filtering media allows operation even in arduous environments.

►7 Minimum pressure valve

Manufactured and designed in house using advanced anti corrosive materials and fully machined at our facilities, to grant maximum reliability in any operating conditions.

►8 Cleaner components in any conditions

A cabinet prefiltering panel (available from 18.5 kW) inhibits dust and dirt from entering the inside of the compressor cabinet increasing the life of air filters and the drive belt by 15%, whilst keeping coolers cleaner thereby reducing operating temperature.

►9 Simple maintenance

All of the internal mechanical and service parts are easy to access, for fast and simple routine maintenance.

MICRO 2.2-5.5 kW: simple, silent and economical.

- ▶ Extremely quiet operation.
- ▶ Very compact design.
- ▶ Anti-rotation system.
- ▶ Low maintenance costs.
- ▶ Ease of installation and use.
- ▶ Plug and play.



The MICRO range is available in 2 versions:

- **MICRO "SE" 2.2-4 kW:** electromechanical ON/OFF switch, with motor protection.
The pressure gauge and hour counter are included in the control panel.
Easy to use, no idle running means considerable energy saving.

- **MICRO 4-5.5 kW:** star-delta starter, including the ETMII electronic controller, which controls the complete operation of the machine.

Micro SE 2.2-3.0-4.0

2.2-4 kW

Available versions:

- floor mounted compressor
- compressor + air receiver
- compressor + air receiver + air dryer
(air receiver: 200 liters)

Air-end:

FS14



Controller:

—

Fixed speed

Micro 4.0-5.5

4-5.5 kW

Available versions:

- floor mounted compressor
- compressor + air receiver
- compressor + air receiver + air dryer
(air receiver: 200, 270 or 500 liters)

Air-end:

FS14



Controller:

ETMII



Fixed speed

PLUS 7.5-15 kW: the modular choice.



- ▶ Extremely quiet operation.
- ▶ Very compact design.
- ▶ High efficiency.
- ▶ Low R.P.M.
- ▶ Ease of installation and use.
- ▶ Plug and play.

Dryer module ▶

The models with air receiver are also available with dryer ("ES" versions): supplied ready to operate with a minimum of installation.



Condensate ball valve (1)

Receiver-mounted models with ball valve for convenient discharge of condensate (refer to local regulations).

Easy to transport (2)

The machine is particularly easy to lift with a fork truck or hand truck thanks to a steel bar secured between the feet at the base of the air receiver (both at the front and to the side).

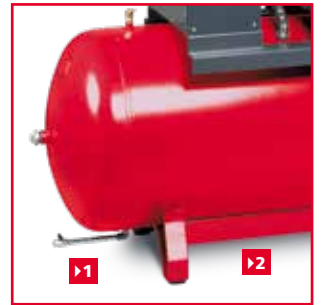

Plus 8-11-15

7.5-15 kW

Available versions:

- floor mounted compressor
- compressor + air receiver
- compressor + air receiver + air dryer
(air receiver: 270 or 500 liters)

Air-end:
FS26 TF



Controller:
ETMII



Fixed speed

Plus 16

15 kW

Available versions:

- floor mounted compressor
- compressor + air receiver
- compressor + air receiver + air dryer
(air receiver: 500 liters)

Air-end:
FS50 TF



Controller:
ETMII



Fixed speed

PLUS 18.5-37 kW: new design with higher performance.

The new PLUS compressors from 18.5 to 75 kW are entirely designed and manufactured so that they function as an integrated system with the maximum efficiency.

All of the most important components within the compressor are manufactured in house using state of the art methods including the use of very modern machine tool and process control technology: this allows full control of the production cycle and maximum control in respect to the total quality of the entire compressor.

The cooling air flow, channeled by the thermostatic controlled centrifugal fan, provides maximum circulation to the oversized combined oil/air heat exchanger: this permits the compressor to run at optimised temperature even in severe ambient conditions.



◀ **Dryer module**
Plus 18.5, 22, 31 and 38 models with dryer module (ES) provide clean, dry air that improves the system's reliability, avoids costly downtime and production delays, and safeguards the quality of the final product.



Plus 18.5-22

18.5-22 kW

Available versions:

- base compressor
- compressor + air dryer

Air-end:
FS50TF



Controller:
ETIV



Fixed or Variable Speed (Plus 22 VS)

Plus 31-38

30-37 kW

Available versions:

- base compressor
- compressor + air dryer

Air-end:
FS100
FS130



Controller:
ETIV



Fixed or Variable Speed (Plus 38 VS)

PLUS 45-75 kW: a quality choice.

- ▶ Extremely quiet operation.
- ▶ High performance screw air-end.
- ▶ Ease of access for routine maintenance.
- ▶ Low maintenance costs.
- ▶ Ease of installation and use.
- ▶ Prefiltering panel.



Plus 45-55

45-55 kW

Available versions:
- base compressor



Plus 56-75

55-75 kW

Available versions:
- base compressor

Air-end:
FS130



Air-end:
FS250



Controller:
ETIV



Fixed speed

Controller:
ETIV



Fixed or Variable Speed (Plus 56 and Plus 75 VS)

Advanced electronic controllers

ETMII

Installed on models from 4 to 15 kW.



- ▶ Four maintenance timers (air filter, oil, oil filter, oil separator).
- ▶ Automatic re-start after power failure (subject to safety conditions).
- ▶ Cooling fan temperature control.
- ▶ Compressor remote start facility.
- ▶ Integrated phase sequence relay.

Controller with multi-function backlight display, the menu is alphanumeric type. The main screen display indicates:

- Working pressure (offload/load);
- Oil temperature;
- Total working hours;
- On-load working hours;
- Compressor status led (stand-by, offload, load);
- Hours remaining before maintenance.

ETIV

Installed on models from 18.5 to 75 kW.



Controller with multi-function backlight LCD graphic display, the menu is drop down type. The main screen display indicates:

- ▶ operating pressures;
- ▶ oil temperature;
- ▶ compressor status (stand-by, un-loaded, loaded);
- ▶ fan status (off/on);
- ▶ date and time;
- ▶ remaining hours for maintenance;
- ▶ flow rate supplied percentage
- ▶ Duty cycle compressor (tot. hours a carico)

▶ Weekly programming

With the ETIV controller, it is possible to set up to 9 independent operating programs. For each program it is possible to set the switching on and off times, the days of the week in which it must work and the relative pressure range. In case of a system with several compressors, both at fixed and variable speed, it is possible to set various programs to create a "virtual network" (without the need to physically connect them together).

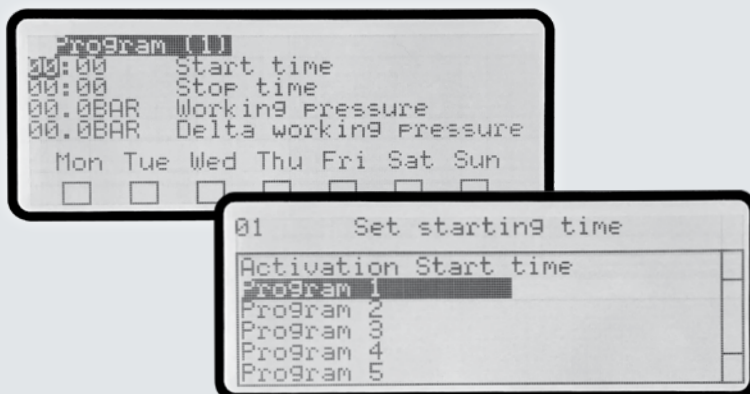

Variable speed drive

Nowadays, the reduction of the energy consumption has become a global challenge in terms of environmental impact. Reducing power consumption and protecting our valuable energy resources represents one of the greatest global environmental challenges of our times.

The Plus series version with 22, 37, 55 and 75 kW electric motor are available in a variable speed drive version, providing high performance combined with the most effective energy saving solution.

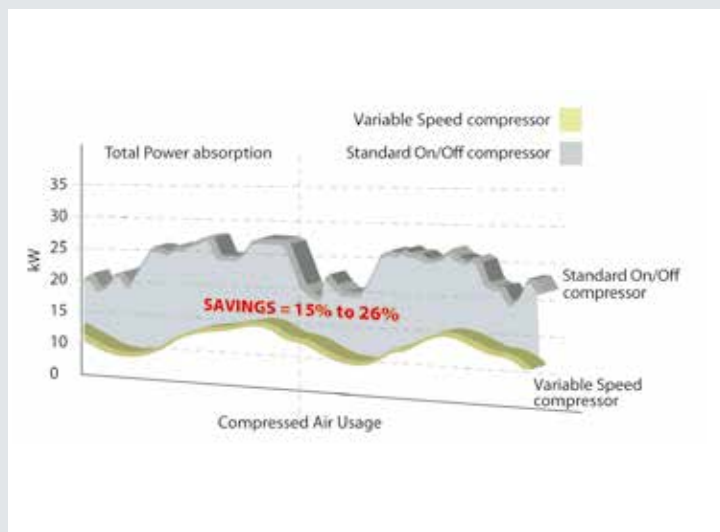

The graph below shows the significant energy saving using variable speed compressors in a typical installation.

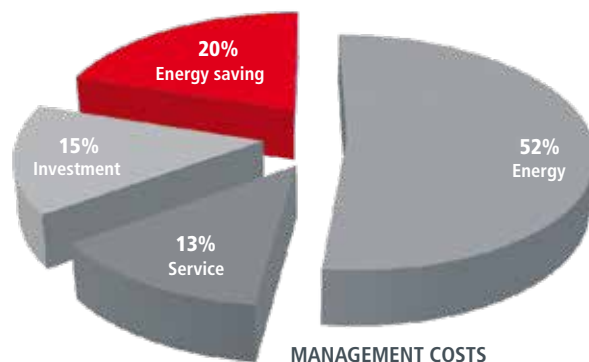

The application of a frequency inverter, able to dynamically adjust the voltage/frequency/current values of the motor, allows the elimination of unnecessary power losses by constantly adjusting the generation of compressed air to match the real air demand, offering many proven advantages for the user in terms of reducing energy consumption:

- ▶ Continuous regulation of the motor speed and compressed air generation to precisely match the air demand.
- ▶ The air output is constantly adjusted between 40% and 100% of the compressor full capacity.
- ▶ Constant and accurate air pressure control selectable at any value between 6 and 10 bar (13 bar on demand).
- ▶ Energy consumption is proportional to the delivered compressed air so you only pay for the compressed air that is used!

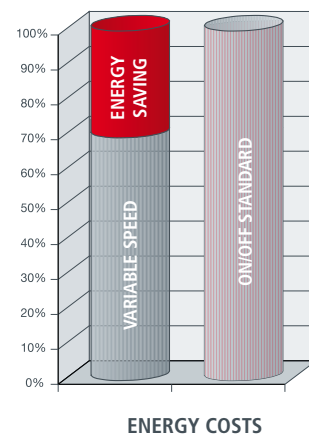

SMS Device Service Management System

SMS is the innovative device for remote control and predictive maintenance of screw compressors fitted with an ETIV controller. If the device is configured on internet networks via Wi-Fi or Ethernet, e-mails can be automatically sent in case of faults and/or automatic periodic e-mails (every hour, every day, every week) so as to monitor correct compressor operation and the remaining hours for the main scheduled maintenance.

Preventive and targeted maintenance:

- ▶ automatic sending of e-mails in case of alarms,
- ▶ possibility of sending e-mails which notify the compressor status and settings at pre-set intervals (hourly, daily or weekly).

Remote control of the compressor:

- ▶ no additional software is required,
- ▶ on/off control,
- ▶ access to the various menu levels (user, service),
- ▶ compressor online status check.



9062744

ANTENNA+SMS DEVICE KIT



EATool - EASoftware Detection and analysis of energy consumption

The energy efficiency of a production plant using compressed air allows for countless advantages for the company's entire production process, in terms of consumption and costs.

Based on decades of experience in the industrial sector, Fini provides a professional auditing service to companies, through skilled technicians and advanced measurement and analysis equipment (EATool and EASoftware). Such equipment allows us to offer one or more rotary screw compressors, in alternative to the existing ones, to achieve considerable annual economic and energy savings.



EATool

- ▶ Designed to measure pneumatic systems where up to 4 compressors work.
- ▶ Measurements are downloaded to a USB drive (included).
- ▶ Supplied: up to 4 x 400 A ampere clamps (optional up to 1000A) and a pressure probe.
- ▶ Possible equipment sale or rental.

EASoftware

- ▶ Acquires the actual consumption of a compressed air system.
- ▶ Processes a complete Energy Audit of the system.
- ▶ Suggests one or more compressors as an alternative to the existing ones, to achieve the highest energy savings.

Optimised control in the compressor room

Many compressed air stations include several compressors: EasyX4 is a weekly programmable sequencer, capable of configuring up to 4 compressors, based on the amount of air actually required.

EasyX4 is the easiest solution for compressor sequencing and supervision over complex systems of compressors, up to 4 units: fixed speed.

The programming is intuitive. It is sufficient to set the 4 pressure ranges (if 4 is the number of connected units) and later define at what time the entire compressor station shall start and stop, assigning at which pressure each compressor must work.



Three programming levels:

- ▶ **MANUAL:** compressors are fixed to a given operational pressure range;
- ▶ **AUTOMATIC:** with pressure range swapping after a programmable time interval;
- ▶ **GROUP PROGRAMMING:** where compressors can be switched within groups.

#405531604 CONTROL UNIT EASY X4

HRS Heat Recovery System

HRS is a system for the recovery of the heat generated by the screw compressors, for the production of hot water.

Most of the energy used to produce compressed air is actually converted into heat: up to 90% of this energy is reusable! About 75% of the energy used is found in the lubrication and cooling circuit and can be used as a heat source, the remaining 15% is contained in the compressed air which enters the network. It is therefore quite simple to recover the thermal energy (for alternative use) in the compression process... valuable energy that is normally wasted!



▶ Plate oil-water heat exchanger

▶ Water pump

The HRS system can be used on all oil-injected screw compressors.

HEAT OF COMPRESSION

- 4% Heat remaining in the air
- 2% Losses by radiation
- 13% Heat removed from the air cooler
- 72% Heat removed from the oil cooler
- 9% Heat radiated by the electric motor

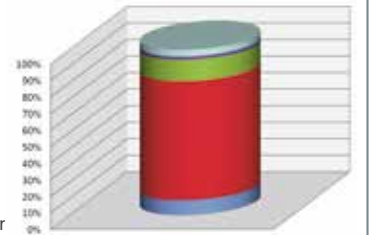

Recover energy - Save money!

How great the recovery of energy actually is, depends of course on the size of the compressors and the type of replaced energy (electricity, gas, heating oil), but the investment becomes very important for the compressors starting from 11 kW installed power. Given the current energy costs, the return on investment of a typical heat recovery system can be as short as 6 months with less than 2 years being the standard (with reference to a plate heat exchanger for heating systems).

Heat recovery is a real opportunity to increase the effectiveness of a compressed air system, the impact on energy costs allows greater savings, up to 3 times compared to even the most efficient compressor.



Long Life Kit for screw compressors scheduled maintenance

- ▶ **FSN original spare parts** have been rigorously selected, checked and tested by specialised technicians to ensure the utmost efficiency and endurance of the compressor. The parts are stocked in our "LOGIMAT" centralised and automated warehouse in Zola Predosa (BO) - Italy, where 12,000 part codes on 10,000 sqm are managed every day.
- ▶ Specialised staff are continuously in contact with our distribution centres worldwide, to deliver spare parts to our customers in the shortest possible time.
- ▶ The use of **FSN Long Life Kit**, specifically studied for screw compressors, extends maintenance intervals, cutting down service costs and ensuring consistent product performance.
Ask for the catalog with reference codes, suitable for all Micro and Plus compressors.



RotarEcofluid mineral based lubricants

- ▶ Formulated with high quality selected mineral base oils enhanced with advanced anti-oxidants, anti-wear (zinc free), rust preventers and antifoams, the FSN RotarECOFLUID oil offers an optimal control of oxidation and residue deposits as well as an excellent level of thermal stability and oxidation to ensure the longevity of equipment and long life performances.

#600000020	Oil RotarECOFLUID 46 cSt - 1 x 3,8 L (3,3 kg) can
#600000021	Oil RotarECOFLUID 46 cSt - 1 x 20 L (17,36 kg) can
#600000022	Oil RotarECOFLUID 46 cSt - 1 x 200 L (174 kg) drum



RotEnergy synthetic based lubricants

- ▶ Our synthetic based lubricants - FSN RotEnergy - have been specifically designed for use on our screw compressors, supplied by world leading manufacturers. They are available in cans, drums or multi packs: RotEnergyPlus: ensures quick water separation and lower friction and energy consumption, it extends maintenance intervals and ensures excellent lubrication of the bearings while offering excellent protection. RotEnergyFood: a high quality lubricant for rotary compressors, suitable for use in the food industry, where specific quality standards are required.

#600000018A	Oil RotEnergyPlus 46 cSt - 1 x 3,8 L (3,25 kg) can
#600000009A	Oil RotEnergyPlus 46 cSt - 4 x 3,8 L (3,25 kg) each cans
#600000007A	Oil RotEnergyPlus 46 cSt - 1 x 19 L (16 kg) can
#600000012A	Oil RotEnergyPlus 46 cSt - 1 x 208 L (181 kg) drum

#600000014A	Oil RotEnergyFood 46 cSt - 4 x 3,9 L (3,25 kg) each cans
#600000016A	Oil RotEnergyFood 46 cSt - 1 x 19 L (18,5 kg) can
#600000017A	Oil RotEnergyFood 46 cSt - 1 x 208 L (175 kg) drum

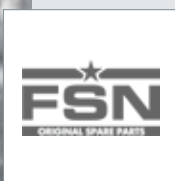

- ▶ On the **FINI** website, it is possible to check out the exploded views and spare parts lists for any compressor model whenever needed.

www.finicompressors.com

- ▶ Our **Hot-Line** service can prepare and ship urgent spare parts orders within a day (if received before 12.00 p.m.).



Model	Code	l	Compressor		FREE AIR DELIVERED			MAX. PRESSURE		Air-end	dB(A)	G	kg	Dimensions (mm)			kg	Dimensions (mm)		
			kW	HP	l/min.	m³/min.	c.f.m.	bar	psi					L	H	W		L	H	W
MICRO SE - ELECTROMECHANICAL 2.2 ÷ 4 kW																				
MICRO SE 2.2-08 M	V51JU60FNM560	-	2.2	3	300	0.3	10.6	8	116	FS14	58	1/2"	98	580x480x760	109	720x670x970				
MICRO SE 2.2-08	V51JU72FNM760	-	2.2	3	325	0.325	11.5	8	116	FS14	58	1/2"	93	580x480x760	104	720x670x970				
MICRO SE 2.2-10 M	V51JT60FNM560	-	2.2	3	240	0.24	8.5	10	145	FS14	58	1/2"	98	580x480x760	109	720x670x970				
MICRO SE 2.2-10	V51JT72FNM760	-	2.2	3	290	0.29	10.2	10	145	FS14	58	1/2"	93	580x480x760	104	720x670x970				
MICRO SE 2.2-08-200	V77JU72FNM701	200	2.2	3	325	0.325	11.5	8	116	FS14	58	1/2"	144	1440x510x1280	169	1530x610x1460				
MICRO SE 2.2-10-200	V77JT72FNM701	200	2.2	3	290	0.29	10.2	10	145	FS14	58	1/2"	144	1440x510x1280	169	1530x610x1460				
MICRO SE 2.2-10-200 M	V77JT60FNM501	200	2.2	3	240	0.24	8.5	10	145	FS14	58	1/2"	149	1440x510x1280	174	1530x610x1460				
MICRO SE 2.2-08-200 ES	V77JU72FNM801	200	2.2	3	325	0.325	11.5	8	116	FS14	58	1/2"	162	1440x510x1280	187	1530x610x1460				
MICRO SE 2.2-10-200 ES	V77JT72FNM801	200	2.2	3	290	0.29	10.2	10	145	FS14	58	1/2"	162	1440x510x1280	187	1530x610x1460				
MICRO SE 3.0-08	V51JS72FNM760	-	3	4	430	0.43	15.2	8	116	FS14	59	1/2"	99	580x480x760	110	720x670x970				
MICRO SE 3.0-10	V51JQ72FNM760	-	3	4	385	0.385	13.6	10	145	FS14	59	1/2"	99	580x480x760	110	720x670x970				
MICRO SE 3.0-08-200	V77JS72FNM701	200	3	4	430	0.43	15.2	8	116	FS14	59	1/2"	149	1440x510x1280	174	1530x610x1460				
MICRO SE 3.0-10-200	V77JQ72FNM701	200	3	4	385	0.385	13.6	10	145	FS14	59	1/2"	149	1440x510x1280	174	1530x610x1460				
MICRO SE 3.0-08-200 ES	V77JS72FNM801	200	3	4	430	0.43	15.2	8	116	FS14	59	1/2"	167	1440x510x1280	192	1530x610x1460				
MICRO SE 3.0-10-200 ES	V77JQ72FNM801	200	3	4	385	0.385	13.6	10	145	FS14	59	1/2"	167	1440x510x1280	192	1530x610x1460				
MICRO SE 4.0-08	V51JR72FNM760	-	4	5.5	580	0.58	20.5	8	116	FS14	60	1/2"	108	580x480x760	119	720x670x970				
MICRO SE 4.0-10	V51JP72FNM760	-	4	5.5	485	0.485	17.1	10	145	FS14	60	1/2"	108	580x480x760	119	720x670x970				
MICRO SE 4.0-08-200	V77JR72FNM701	200	4	5.5	580	0.58	20.5	8	116	FS14	60	1/2"	153	1440x510x1280	178	1530x610x1460				
MICRO SE 4.0-10-200	V77JP72FNM701	200	4	5.5	485	0.485	17.1	10	145	FS14	60	1/2"	153	1440x510x1280	178	1530x610x1460				
MICRO SE 4.0-08-200 ES	V77JR72FNM801	200	4	5.5	580	0.58	20.5	8	116	FS14	60	1/2"	171	1440x510x1280	196	1530x610x1460				
MICRO SE 4.0-10-200 ES	V77JP72FNM801	200	4	5.5	485	0.485	17.1	10	145	FS14	60	1/2"	171	1440x510x1280	196	1530x610x1460				
MICRO - ELECTRONIC 4 ÷ 5.5 kW																				
MICRO 4.0-08	V51JR92FNM760	-	4	5.5	580	0.58	20.5	8	116	FS14	60	1/2"	103	580x480x760	114	720x670x970				
MICRO 4.0-10	V51JP92FNM760	-	4	5.5	485	0.485	17.1	10	145	FS14	60	1/2"	103	580x480x760	114	720x670x970				
MICRO 4.0-13	V51JV92FNM760	-	4	5.5	330	0.33	11.7	13	189	FS14	60	1/2"	103	580x480x760	114	720x670x970				
MICRO 4.0-08-200	V77JR92FNM701	200	4	5.5	580	0.58	20.5	8	116	FS14	60	1/2"	149	1440x510x1280	174	1530x610x1460				
MICRO 4.0-10-200	V77JP92FNM701	200	4	5.5	485	0.485	17.1	10	145	FS14	60	1/2"	149	1440x510x1280	174	1530x610x1460				
MICRO 4.0-08-200 ES	V77JR92FNM801	200	4	5.5	580	0.58	20.5	8	116	FS14	60	1/2"	167	1440x510x1280	192	1530x610x1460				
MICRO 4.0-10-200 ES	V77JP92FNM801	200	4	5.5	485	0.485	17.1	10	145	FS14	60	1/2"	167	1440x510x1280	192	1530x610x1460				
MICRO 5.5-08	V51JW92FNM760	-	5.5	7.5	720	0.72	25.4	8	116	FS14	64	1/2"	126	600x520x780	137	720x670x970				
MICRO 5.5-10	V51JO92FNM760	-	5.5	7.5	650	0.65	23	10	145	FS14	64	1/2"	126	600x520x780	137	720x670x970				
MICRO 5.5-13	V51JM92FNM760	-	5.5	7.5	485	0.485	17.1	13	189	FS14	64	1/2"	126	600x520x780	137	720x670x970				
MICRO 5.5-08-270	V91JW92FNM701	270	5.5	7.5	720	0.72	25.4	8	116	FS14	64	1/2"	202	1560x570x1390	237	1720x750x1680				
MICRO 5.5-10-270	V91JO92FNM701	270	5.5	7.5	650	0.65	22.9	10	145	FS14	64	1/2"	202	1560x570x1390	237	1720x750x1680				
MICRO 5.5-08-270 ES	V91JW92FNM801	270	5.5	7.5	720	0.72	25.4	8	116	FS14	64	1/2"	229	1560x570x1390	264	1720x750x1680				
MICRO 5.5-10-270 ES	V91JO92FNM801	270	5.5	7.5	650	0.65	22.9	10	145	FS14	64	1/2"	229	1560x570x1390	264	1720x750x1680				
MICRO 5.5-08-500	V83JW92FNM701	500	5.5	7.5	720	0.72	25.4	8	116	FS14	64	1/2"	268	2000x600x1480	308	2070x800x1680				
MICRO 5.5-10-500	V83JO92FNM701	500	5.5	7.5	650	0.65	22.9	10	145	FS14	64	1/2"	268	2000x600x1480	308	2070x800x1680				
MICRO 5.5-08-500 ES	V83JW92FNM801	500	5.5	7.5	720	0.72	25.4	8	116	FS14	64	1/2"	304	2000x600x1480	344	2070x800x1680				
MICRO 5.5-10-500 ES	V83JO92FNM801	500	5.5	7.5	650	0.65	22.9	10	145	FS14	64	1/2"	304	2000x600x1480	344	2070x800x1680				

Free air delivery as per ISO 1217 Annex C, at 7.5 - 9.5 bar at the compressor outlet. ± 3 dB (A) as PNEUROP/CAGI PN-NTC 2.3.

M = single-phase - ES = with dryer











Model	Code	L	Compressor		FREE AIR DELIVERED			MAX		Air-end	dB(A)	G	kg	L x W x H (mm)	kg	L x W x H (mm)
			kW	HP	l/min.	m³/min.	c.f.m.	bar	psi							
PLUS 7.5 ÷ 11 kW																
PLUS 8-08	V60NG92FNM760	-	7.5	10	1250	1.25	44.1	8	116	FS26	68	3/4"	205	800x650x980	219	940x770x1150
PLUS 8-10	V60NH92FNM760	-	7.5	10	1000	1	35.3	10	145	FS26	68	3/4"	205	800x650x980	219	940x770x1150
PLUS 8-13	V60NI92FNM760	-	7.5	10	750	0.75	26.5	13	189	FS26	68	3/4"	205	800x650x980	219	940x770x1150
PLUS 8-15	V60NI92FNM960	-	7.5	10	670	0.67	23.7	15	218	FS26	68	3/4"	205	800x650x980	219	940x770x1150
PLUS 8-08-270	V91NG92FNM701	270	7.5	10	1250	1.25	44.1	8	116	FS26	68	3/4"	288	1560x650x1550	318	1720x750x1760
PLUS 8-10-270	V91NH92FNM701	270	7.5	10	1000	1	35.3	10	145	FS26	68	3/4"	288	1560x650x1550	318	1720x750x1760
PLUS 8-13-270	V91NI92FNM701	270	7.5	10	750	0.75	26.5	13	189	FS26	68	3/4"	337	1560x650x1550	367	1720x750x1760
PLUS 8-15-270	V91NI92FNM901	270	7.5	10	670	0.67	23.7	15	218	FS26	68	3/4"	337	1560x650x1550	367	1720x750x1760
PLUS 8-08-270 ES	V91NG92FNM801	270	7.5	10	1250	1.25	44.1	8	116	FS26	68	1"	315	1550x650x1550	345	1720x750x1760
PLUS 8-10-270 ES	V91NH92FNM801	270	7.5	10	1000	1	35.3	10	145	FS26	68	1"	315	1550x650x1550	345	1720x750x1760
PLUS 8-13-270 ES	V91NI92FNM801	270	7.5	10	750	0.75	26.5	13	189	FS26	68	1"	364	1550x650x1550	394	1720x750x1760
PLUS 8-15-270 ES	V91NI92FNM001	270	7.5	10	670	0.67	23.7	15	218	FS26	68	1"	364	1550x650x1550	394	1720x750x1760
PLUS 8-08-500	V83NG92FNM701	500	7.5	10	1250	1.25	44.1	8	116	FS26	68	3/4"	334	2000x650x1640	374	2070x800x1850
PLUS 8-10-500	V83NH92FNM701	500	7.5	10	1000	1	35.3	10	145	FS26	68	3/4"	334	2000x650x1640	374	2070x800x1850
PLUS 8-13-500	V83NI92FNM701	500	7.5	10	750	0.75	26.5	13	189	FS26	68	3/4"	366	2000x650x1640	406	2070x800x1850
PLUS 8-08-500 ES	V83NG92FNM801	500	7.5	10	1250	1.25	44.1	8	116	FS26	68	1"	361	1980x650x1640	401	2070x800x1850
PLUS 8-10-500 ES	V83NH92FNM801	500	7.5	10	1000	1	35.3	10	145	FS26	68	1"	361	1980x650x1640	401	2070x800x1850
PLUS 8-13-500 ES	V83NI92FNM801	500	7.5	10	750	0.75	26.5	13	189	FS26	68	1"	393	1980x650x1640	433	2070x800x1850
PLUS 11-08	V60NL92FNM760	-	11	15	1650	1.65	58.2	8	116	FS26	69	3/4"	216	800x650x980	230	940x770x1150
PLUS 11-10	V60NM92FNM760	-	11	15	1500	1.5	53	10	145	FS26	69	3/4"	216	800x650x980	230	940x770x1150
PLUS 11-13	V60NN92FNM760	-	11	15	1100	1.1	38.8	13	189	FS26	69	3/4"	216	800x650x980	230	940x770x1150
PLUS 11-15	V60NN92FNM960	-	11	15	980	0.98	34.6	15	218	FS26	69	3/4"	216	800x650x980	230	940x770x1150
PLUS 11-08-270	V91NL92FNM701	270	11	15	1650	1.65	58.2	8	116	FS26	69	3/4"	302	1560x650x1550	332	1720x750x1760
PLUS 11-10-270	V91NM92FNM701	270	11	15	1500	1.5	53	10	145	FS26	69	3/4"	302	1560x650x1550	332	1720x750x1760
PLUS 11-13-270	V91NN92FNM701	270	11	15	1100	1.1	38.8	13	189	FS26	69	3/4"	351	1560x650x1550	381	1720x750x1760
PLUS 11-15-270	V91NN92FNM901	270	11	15	980	0.98	34.6	15	218	FS26	69	3/4"	351	1560x650x1550	381	1720x750x1760
PLUS 11-08-270 ES	V91NL92FNM801	270	11	15	1650	1.65	58.2	8	116	FS26	69	1"	329	1550x650x1550	359	1720x750x1760
PLUS 11-10-270 ES	V91NM92FNM801	270	11	15	1500	1.5	53	10	145	FS26	69	1"	329	1550x650x1550	359	1720x750x1760
PLUS 11-13-270 ES	V91NN92FNM801	270	11	15	1100	1.1	38.8	13	189	FS26	69	1"	378	1550x650x1550	408	1720x750x1760
PLUS 11-15-270 ES	V91NN92FNM001	270	11	15	980	0.98	34.6	15	218	FS26	69	1"	378	1550x650x1550	408	1720x750x1760
PLUS 11-08-500	V83NL92FNM701	500	11	15	1650	1.65	58.2	8	116	FS26	69	3/4"	353	2000x650x1640	393	2070x800x1850
PLUS 11-10-500	V83NM92FNM701	500	11	15	1500	1.5	53	10	145	FS26	69	3/4"	353	2000x650x1640	393	2070x800x1850
PLUS 11-13-500	V83NN92FNM701	500	11	15	1100	1.1	38.8	13	189	FS26	69	3/4"	385	2000x650x1640	425	2070x800x1850
PLUS 11-08-500 ES	V83NL92FNM801	500	11	15	1650	1.65	58.2	8	116	FS26	69	1"	380	2000x650x164	420	2070x800x1850
PLUS 11-10-500 ES	V83NM92FNM801	500	11	15	1500	1.5	53	10	145	FS26	69	1"	380	2000x650x164	420	2070x800x1850
PLUS 11-13-500 ES	V83NN92FNM801	500	11	15	1100	1.1	38.8	13	189	FS26	69	1"	412	2000x650x164	452	2070x800x1850









Free air delivery as per ISO 1217 Annex C, at 7.5 - 9.5 - 12.5 - 14.5 bar at the compressor outlet. ± 3 dB (A) as PNEUROP/CAGI PN-NTC 2.3.
ES = with dryer



Model	Code	l	Compressor		FREE AIR DELIVERED					MAX	Air-end	dB(A)	G	kg	L x W x H (mm)	kg	L x W x H (mm)
			kW	HP	l/min.	m ³ /min.	c.f.m.	bar	psi								
PLUS 15 kW																	
PLUS 15-08	V60NP92FNM760	-	15	20	2150	2.15	75.9	8	116	FS26	70	3/4"	220	800x650x980	234	940x770x1150	
PLUS 15-10	V60NQ92FNM760	-	15	20	1850	1.85	65.3	10	145	FS26	70	3/4"	220	800x650x980	234	940x770x1150	
PLUS 15-13	V60NR92FNM760	-	15	20	1500	1.5	53	13	189	FS26	70	3/4"	220	800x650x980	234	940x770x1150	
PLUS 15-15	V60NR92FNM960	-	15	20	1300	1.3	45.9	15	218	FS26	70	3/4"	220	800x650x980	234	940x770x1150	
PLUS 15-08-500	V83NP92FNM701	500	15	20	2150	2.15	75.9	8	116	FS26	70	3/4"	383	2000x650x1640	423	2070x800x1850	
PLUS 15-10-500	V83NQ92FNM701	500	15	20	1850	1.85	65.3	10	145	FS26	70	3/4"	383	2000x650x1640	423	2070x800x1850	
PLUS 15-13-500	V83NR92FNM701	500	15	20	1500	1.5	53	13	189	FS26	70	3/4"	415	2000x650x1640	455	2070x800x1850	
PLUS 15-15-500	V83NR92FNM901	500	15	20	1300	1.3	45.9	15	218	FS26	70	3/4"	415	2000x650x1640	455	2070x800x1850	
PLUS 15-08-500 ES	V83NP92FNM801	500	15	20	2150	2.15	75.9	8	116	FS26	70	1"	412	2000x650x1640	452	2070x800x1850	
PLUS 15-10-500 ES	V83NQ92FNM801	500	15	20	1850	1.85	65.3	10	145	FS26	70	1"	412	2000x650x1640	452	2070x800x1850	
PLUS 15-13-500 ES	V83NR92FNM801	500	15	20	1500	1.5	53	13	189	FS26	70	1"	444	2000x650x1640	484	2070x800x1850	
PLUS 15-15-500 ES	V83NR92FNM601	500	15	20	1300	1.3	45.9	15	218	FS26	70	1"	444	2000x650x1640	484	2070x800x1850	
PLUS 16-08	V60NB92FNM760	-	15	20	2350	2.35	83	8	116	FS50	68	3/4"	234	800x650x980	248	940x770x1150	
PLUS 16-10	V60NY92FNM760	-	15	20	2050	2.05	72.4	10	145	FS50	68	3/4"	234	800x650x980	248	940x770x1150	
PLUS 16-13	V60NW92FNM760	-	15	20	1750	1.75	61.8	13	189	FS50	68	3/4"	234	800x650x980	248	940x770x1150	
PLUS 16-08-500	V83NB92FNM701	500	15	20	2350	2.35	83	8	116	FS50	68	3/4"	410	2000x650x1640	450	2070x800x1850	
PLUS 16-10-500	V83NY92FNM701	500	15	20	2050	2.05	72.4	10	145	FS50	68	3/4"	362	2000x650x1640	402	2070x800x1850	
PLUS 16-13-500	V83NW92FNM701	500	15	20	1750	1.75	61.8	13	189	FS50	68	3/4"	442	2000x650x1640	482	2070x800x1850	
PLUS 16-08-500 ES	V83NB92FNM801	500	15	20	2350	2.35	83	8	116	FS50	68	1"	439	2000x650x1640	479	2070x800x1850	
PLUS 16-10-500 ES	V83NY92FNM801	500	15	20	2050	2.05	72.4	10	145	FS50	68	1"	439	2000x650x1640	479	2070x800x1850	
PLUS 16-13-500 ES	V83NW92FNM801	500	15	20	1750	1.75	61.8	13	189	FS50	68	1"	471	2000x650x1640	511	2070x800x1850	
PLUS 18,5 kW																	
PLUS 18.5-08	V60QA92FNM760	-	18.5	25	2800	2.8	99	8	116	FS50	66	1"	397	1350x800x1130	470	1530x1000x1380	
PLUS 18.5-10	V60QB92FNM760	-	18.5	25	2500	2.5	88	10	145	FS50	66	1"	397	1350x800x1130	470	1530x1000x1380	
PLUS 18.5-13	V60QC92FNM760	-	18.5	25	2150	2.15	76	13	189	FS50	66	1"	397	1350x800x1130	470	1530x1000x1380	
PLUS 18.5-15	V60QC92FNM960	-	18.5	25	1650	1.65	58	15	218	FS50	66	1"	397	1350x800x1130	470	1530x1000x1380	
PLUS 18.5-08 ES	V60QA92FNM860	-	18.5	25	2800	2.8	99	8	116	FS50	66	1" 1/4	447	1700x800x1130	537	2050x1140x1670	
PLUS 18.5-10 ES	V60QB92FNM860	-	18.5	25	2500	2.5	88	10	145	FS50	66	1" 1/4	447	1700x800x1130	537	2050x1140x1670	
PLUS 18.5-13 ES	V60QC92FNM860	-	18.5	25	2150	2.15	76	13	189	FS50	66	1" 1/4	447	1700x800x1130	537	2050x1140x1670	
PLUS 22 kW																	
PLUS 22-08	V60QD92FNM760	-	22	30	3350	3.35	118	8	116	FS50	68	1"	419	1350x800x1130	492	1530x1000x1380	
PLUS 22-10	V60QE92FNM760	-	22	30	3000	3	106	10	145	FS50	68	1"	419	1350x800x1130	492	1530x1000x1380	
PLUS 22-13	V60QF92FNM760	-	22	30	2400	2.4	85	13	189	FS50	68	1"	419	1350x800x1130	492	1530x1000x1380	
PLUS 22-15	V60QF92FNM960	-	22	30	1970	1.97	70	15	218	FS50	68	1"	419	1350x800x1130	492	1530x1000x1380	
PLUS 22-08 ES	V60QD92FNM860	-	22	30	3350	3.35	118	8	116	FS50	68	1" 1/4	469	1700x800x1130	559	2050x1140x1670	
PLUS 22-10 ES	V60QE92FNM860	-	22	30	3000	3	106	10	145	FS50	68	1" 1/4	469	1700x800x1130	559	2050x1140x1670	
PLUS 22-13 ES	V60QF92FNM860	-	22	30	2400	2.4	85	13	189	FS50	68	1" 1/4	469	1700x800x1130	559	2050x1140x1670	

Free air delivery as per ISO 1217 Annex C, at 7.5 - 9.5 - 12.5 - 14.5 bar at the compressor outlet. ± 3 dB (A) as PNEUROP/CAGI PN-NTC 2.3.
ES = with dryer

Model	Code			 FREE AIR DELIVERED			 MAX		Air-end						
		kW	HP	l/min.	m ³ /min.	c.f.m.	bar	psi							dB(A)
PLUS 30 kW															
PLUS 31-08	V60BU92FNM760	30	40	4700	4.7	166	8	116	FS100	70	1" 1/4	663	1530x850x1440	737	1690x1030x1730
PLUS 31-10	V60BV92FNM760	30	40	4200	4.2	148	10	145	FS100	70	1" 1/4	663	1530x850x1440	737	1690x1030x1730
PLUS 31-13	V60BW92FNM760	30	40	3400	3.4	120	13	189	FS100	70	1" 1/4	663	1530x850x1440	737	1690x1030x1730
PLUS 31-08 ES	V60BU92FNM860	30	40	4700	4.7	166	8	116	FS100	70	1" 1/2	728	1860x850x1440	818	2050x1140x1670
PLUS 31-10 ES	V60BV92FNM860	30	40	4200	4.2	148	10	145	FS100	70	1" 1/2	728	1860x850x1440	818	2050x1140x1670
PLUS 31-13 ES	V60BW92FNM860	30	40	3400	3.4	120	13	189	FS100	70	1" 1/2	728	1860x850x1440	818	2050x1140x1670
PLUS 37 kW															
PLUS 38-08	V60BK92FNM760	37	50	5900	5.9	208	8	116	FS130	68	1" 1/4	686	1530x850x1440	760	1690x1030x1730
PLUS 38-10	V60BJ92FNM760	37	50	5200	5.2	184	10	145	FS130	68	1" 1/4	686	1530x850x1440	760	1690x1030x1730
PLUS 38-13	V60BI92FNM760	37	50	4200	4.2	148	13	189	FS130	68	1" 1/4	686	1530x850x1440	760	1690x1030x1730
PLUS 38-08 ES	V60BK92FNM860	37	50	5900	5.9	208	8	116	FS130	68	1" 1/2	751	1860x850x1440	841	2050x1140x1670
PLUS 38-10 ES	V60BJ92FNM860	37	50	5200	5.2	184	10	145	FS130	68	1" 1/2	751	1860x850x1440	841	2050x1140x1670
PLUS 38-13 ES	V60BI92FNM860	37	50	4200	4.2	148	13	189	FS130	68	1" 1/2	751	1860x850x1440	841	2050x1140x1670
PLUS 45 kW															
PLUS 45-08	V60BM92FNM860	45	60	7200	7.2	254	7.5	109	FS130	72	1" 1/2	908	1590x950x1560	994	1800x1200x2110
PLUS 45-10	V60BN92FNM860	45	60	6500	6.5	229	10	145	FS130	72	1" 1/2	908	1590x950x1560	994	1800x1200x2110
PLUS 45-13	V60BQ92FNM860	45	60	5100	5.1	180	13	189	FS130	72	1" 1/2	908	1590x950x1560	994	1800x1200x2110
PLUS 55 kW															
PLUS 55-08	V60BR92FNM760	55	75	8600	8.6	304	7.5	109	FS130	74	1" 1/2	971	1590x950x1560	1057	1800x1200x2110
PLUS 55-10	V60BS92FNM760	55	75	7800	7.8	275	10	145	FS130	74	1" 1/2	971	1590x950x1560	1057	1800x1200x2110
PLUS 55-13	V60BT92FNM760	55	75	6400	6.4	226	13	189	FS130	74	1" 1/2	971	1590x950x1560	1057	1800x1200x2110
PLUS 56-08	V60BA92FNM760	55	75	9300	9.3	328	7.5	109	FS250	70	2"	1320	1800x1090x1860	1430	2000x1290x2270
PLUS 56-10	V60BB92FNM760	55	75	8300	8.3	293	10	145	FS250	70	2"	1320	1800x1090x1860	1430	2000x1290x2270
PLUS 56-13	V60BC92FNM760	55	75	7000	7	247	13	189	FS250	70	2"	1320	1800x1090x1860	1430	2000x1290x2270
PLUS 75 kW															
PLUS 75-08	V60BD92FNM760	75	100	12200	12.2	431	7.5	109	FS250	72	2"	1430	1800x1090x1860	1540	2000x1290x2270
PLUS 75-10	V60BE92FNM760	75	100	10500	10.5	371	10	145	FS250	72	2"	1430	1800x1090x1860	1540	2000x1290x2270
PLUS 75-13	V60BF92FNM760	75	100	8300	8.3	293	13	189	FS250	72	2"	1430	1800x1090x1860	1540	2000x1290x2270

Model	Code			 FREE AIR DELIVERED (max. / min.)			 MAX		Air-end						
		kW	HP	l/min.	m ³ /min.	c.f.m.	bar	psi							dB(A)
PLUS VARIABLE SPEED															
PLUS 22-08 VS	V60QD97FNM760	22	30	3350/1350	3.35/1.35	118/48	8	116	FS50	68	1"	437	1350x800x1130	510	1530x1000x1380
PLUS 22-10 VS	V60QE97FNM760	22	30	3050/1220	3.05/1.22	108/43	10	145	FS50	68	1"	437	1350x800x1130	510	1530x1000x1380
PLUS 22-08 ES VS	V60QD97FNM860	22	30	3350/1350	3.35/1.35	118/48	8	116	FS50	68	1" 1/4	487	1700x800x1130	577	2050x1140x1670
PLUS 22-10 ES VS	V60QE97FNM860	22	30	3050/1220	3.05/1.22	108/43	10	145	FS50	68	1" 1/4	487	1700x800x1130	577	2050x1140x1670
PLUS 31-08 VS	V60BU97FNM760	30	40	4700/1700	4.70/1.70	166/60	8	116	FS100	67	1" 1/4	682	1530x850x1440	756	1690x1030x1730
PLUS 31-10 VS	V60BV97FNM760	30	40	4200/1500	4.20/1.50	148/53	10	145	FS100	68	1" 1/4	682	1530x850x1440	756	1690x1030x1730
PLUS 31-13 VS	V60BW97FNM760	30	40	3400/1300	3.40/1.30	120/46	13	189	FS100	64	1" 1/4	682	1530x850x1440	756	1690x1030x1730
PLUS 38-08 VS	V60BK97FNM760	37	50	6000/2400	6.00/2.40	212/85	8	116	FS130	72	1" 1/4	705	1530x850x1440	779	1690x1030x1730
PLUS 38-10 VS	V60BJ97FNM760	37	50	5300/2100	5.30/2.10	187/74	10	145	FS130	72	1" 1/4	705	1530x850x1440	779	1690x1030x1730
PLUS 38-08 ES VS	V60BK97FNM860	37	50	6000/2400	6.00/2.40	212/85	8	116	FS130	72	1" 1/2	770	1860x850x1440	860	2050x1140x1670
PLUS 38-10 ES VS	V60BJ97FNM860	37	50	5300/2100	5.30/2.10	187/74	10	145	FS130	72	1" 1/2	770	1860x850x1440	860	2050x1140x1670
PLUS 56-08 VS	V60BA97FNM760	55	75	9300/3700	9.30/3.70	328/131	7.5	109	FS250	70	2"	1365	1800x1090x1860	1475	2000x1290x2270
PLUS 56-10 VS	V60BB97FNM760	55	75	8300/3300	8.30/3.30	293/116	10	145	FS250	70	2"	1365	1800x1090x1860	1475	2000x1290x2270
PLUS 75-08 VS	V60BD97FNM760	75	100	12200/4800	12.20/4.80	431/169	7.5	109	FS250	72	2"	1495	1800x1090x1860	1605	2000x1290x2270
PLUS 75-10 VS	V60BE97FNM760	75	100	10500/4200	10.50/4.20	371/148	10	145	FS250	72	2"	1495	1800x1090x1860	1605	2000x1290x2270

Free air delivery as per ISO 1217 Annex C, at 7 - 7.5 - 9.5 - 12.5 bar at the compressor outlet. ± 3 dB (A) as PNEUROP/CAGI PN-NTC 2.3.
ES = with dryer - VS = Variable Speed

A wide range of solutions for industrial applications



TERA
Oil-injected rotary screw compressors with direct transmission without gears, at fixed or variable speed and power range from 110 to 250 kW.



K-MAX
Oil-injected rotary screw compressors with direct transmission and power range from 5.5 to 90 kW, at fixed or variable speed with permanent magnet motors.



MiniCUBE
Oil-injected rotary screw compressors with direct transmission and power of 2.2 kW.



CUBE
Oil-injected rotary screw compressors, with direct transmission and power range from 4 to 7.5 kW.



OS Scroll
Single and multi-scroll fixed speed oil-free compressors with power range from 2.2 to 30 kW.



AIR TREATMENT
Air driers, filters, accessories and a wide range of products for compressed air treatment.



The "Trust" warranty can be easily extended online through EasyConnect, the new Fini service portal specially created to simplify customers' lives by providing them with quick, clear responses about product availability, order management and goods shipping times.

Protect your investment, extend the warranty up to **5** years!

When installing your new Fini screw compressor, join the "Trust" Warranty 3- to 5-year extension program to benefit from countless advantages by maximising the effectiveness, safety and duration over time of your investment. Thanks to scheduled maintenance programs exclusively performed by FINI Authorised Assistance Centres, you can rely on timely, highly professional service, as well as on the use of only original spare parts guaranteed by the FSN brand.



FNA S.p.A. Via Einaudi, 6 - 10070 Robassomero (TO) - ITALY
T: +39 011 92 33 000 - F: +39 011 92 41 138
info@fnacompressors.com - www.fnacompressors.com



a brand of



follow us on:



www.finicompressors.it