

COMPRESSORS
RotarScrew

GB

use & maintenance
MANUAL

Rotar Giga SD 75-100 STC



GENERAL INFORMATION 3
SAFETY INDICATIONS 4
INSTALLATION 6
CONTROLS AND SETTINGS 8
ALARMS 10
START-UP PROCEDURE AND DISPLAY INFORMATION 11
OPERATION 13
MAINTENANCE 14
TROUBLE-SHOOTING 19
TECHNICAL FEATURES 19
WIRING DIAGRAM 20

STANDARD EQUIPMENT

Check outfit carefully. Later claims for missing parts will not be accepted.
The following accessories are supplied with the compressor:
no. 1 oil drain tube
no. 1 door key
no. 1 user's guide
no. 1 air delivery kit

CONDITION OF THE MACHINE WHEN SUPPLIED

Every compressor is shop tested and delivered ready to be installed and to be set at work.
The oil used is: RotEnergy Plus

SAFETY INDICATIONS

GENERAL

- Rotary compressors are intended for heavy continuous industrial use. They are especially suitable for industrial applications requiring high air consumption for a long time.
- The compressor should be run and operated only in compliance with the indications given in this manual. Safely keep this manual in a known and easily reachable place for the whole working life of the compressor.
- A supervisor shall be appointed in the company, in which the compressor is installed. He/she shall be responsible for compressor inspections, adjustments and maintenance. Should a substitute be appointed for the supervisor, he/she shall carefully read the user's guide and all possible comment on service and maintenance carried out so far.

SYMBOLS USED IN THE MANUAL

Some symbols are used to highlight danger situations, give recommendations or information. These symbols are usually positioned next to the text, a figure or at the top of a page (in this case they refer to all subjects dealt with in that page).

Carefully read symbol meaning below.



CAUTION!

Important description on service, dangerous situation, safety, accident prevention recommendations and/or very important information.



All operations to be strictly carried out only after powering off the machine.



STOP MACHINE!

All operations to be strictly carried out only after stopping the machine.



SPECIALIZED PERSONNEL!

All operations to be strictly carried out only by specialized technician.

POWER OFF!

SYMBOLS ON THE COMPRESSOR

The compressor has several labels to highlight possible danger and give recommendations on what to do during machine operation or in special situations.

Please comply with these indications.

Warning symbols



Danger! Hot!



Danger! Electric shock!



Danger! Hot gas or harmful gas within working area



Danger! Pressurized container



Danger! Mechanical moving parts



Caution! Maintenance works in progress



Danger! Machine can restart automatically

Prohibition symbols



Prohibited! Do not open doors during compressor operation



Prohibited! Press emergency button for compressor immediate stop. Do not use line knife switch.



Prohibited! Do not use water on electric equipment to extinguish fire.

Obligation symbols



Compulsory! Read instructions for use carefully.

Read this page carefully before servicing the compressor.

SAFETY INDICATIONS

GB

WHAT TO DO:

Make sure that mains voltage corresponds to the voltage indicated on CE plate and that cable of suitable cross-section are used for electric connections.

Always check oil level before starting the compressor.

Be familiar with emergency stop control and all other controls.

Empty the air tank and/or oil separator and unplug the connector before any maintenance work, so to avoid accidental start.

Ensure that all parts have been correctly reassembled after any maintenance work.

Keep children and animals off the working area to avoid injuries caused by devices connected to the compressor.

nsure that temperature of the working environment ranges between +2 and + 45 °C. Compressor working temperature shall range between 70-85°C (>20-25°C room temperature). Lower temperatures may causes condensate accumulation inside the oil separator tank (inside the compressor). **Check for condensate and if necessary, drain it (see maintenance).**

The compressor should be installed and operated in a non-explosive environment.

Allow at least 50 cm between the compressor and the wall so to allow free air flow to the fan.

Press the emergency button on the control panel only in case of actual need so as to avoid possible damages to people or the very compressor.

When calling for technical assistance and/or advice, always mention model and serial number indicated on CE plate.

Always follow the maintenance schedule specified in the user's guide.

WHAT NOT TO DO:

Do not touch inner parts and pipes as they are very hot during compressor operation and stay hot for a certain time after compressor stop.

Do not position inflammable or nylon objects or cloths close to and onto the compressor.

Do not move the compressor when the tank is under pressure.

Do not operate the compressor if the power cable is damaged or defective or if connection is unstable.

Do not operate the compressor in explosive environment or in case of naked flames.

Do not operate the compressor in wet or dusty environments.

Never aim the air jet at people or animals.

Do not allow unauthorized people to operate the compressor and give them all required instructions.

Do not hit fans with blunt objects as they might break during compressor operation.

Never operate the compressor without air filter.

Do not tamper with safety and adjusting devices.

Never operate the compressor when doors/panels are open or removed.

PRODUCT IDENTIFICATION

The compressor You have purchased has its own CE plate showing the following data:

- 1) Manufacturer's data
- 2) CE mark – year of manufacture
- 3) TYPE = name of the compressor
CODE = compressor code
SERIAL NO. = serial number of the compressor You have purchased (to be always mentioned when calling for technical assistance)
- 4) air delivered by the compressor expressed in (l/min) and (cfm)
- 5) max. operating pressure (bar and PSI) – compressor noise level in dB(A)
- 6) electric data: voltage (V/ph), frequency (Hz), absorption (A) - power (HP and kW), rotations per minute (Rpm).
- 7) other approvals

1	CE 2
3	
4	5
6	7

Read this page carefully before servicing the compressor.

INSTALLATION



COMPRESSOR DESCRIPTION (fig.1-2)

The compressor essentially consists of:

- 1) Oil separator filters
- 2) Screw/motor support plate
- 3) Motor
- 4) Suction regulator
- 5) Air intake filter
- 6) Air-oil radiator
- 7) Electric box /control panel
- 8) Min. pressure valve
- 9) Oil separator tank/oil separator filter
- 10) Oil filter
- 11) Screw compressor
- 12) Electrical cabinet

UNPACKING AND HANDLING

The compressor is usually shipped to a Customer into a special packing so to protect the compressor against transport damages.

As the compressor is very heavy (see "technical features" table), it must be lifted only by means of suitable capacity driven by specialized personnel.

Compressor base has slots. The compressor is not pre-set to be lifted from above with a crane or a hoist.

Do not stand within fork lift truck working area and keep safety distance.

Perform the following after moving the compressor to the installation place:

- Unpack the compressor. Wear protective gloves and use suitable tools (follow instructions on the crate)
- Check the (outer) good condition of the machine.
- Open the access doors and check all inner parts (visual check)
- Dispose of the packaging in compliance with the current waste disposal regulations.

PLACEMENT (fig.3)

The room chosen for the installation of the compressor should meet the following requirements and comply with current safety and accident prevention regulations:

A) low percentage of dust suspended in air,

B) Proper room ventilation and size that allow room temperature (**5°C ÷ 50°C**) to be maintained - with the machine running.

Min. air intake opening: 2 sq. m

C) In the event of inadequate hot air discharge, fit three or more exhaust fans as high as possible.

• The condensate is a polluting mixture and should not be disposed of into the sewage system or wasted in the environment. The sump should be equipped either with a valve and a removable container or connected to a suitable piece of equipment oil-water separator.

Dimensions shown in fig. 2 are indicative. It is recommended to comply with given indications.

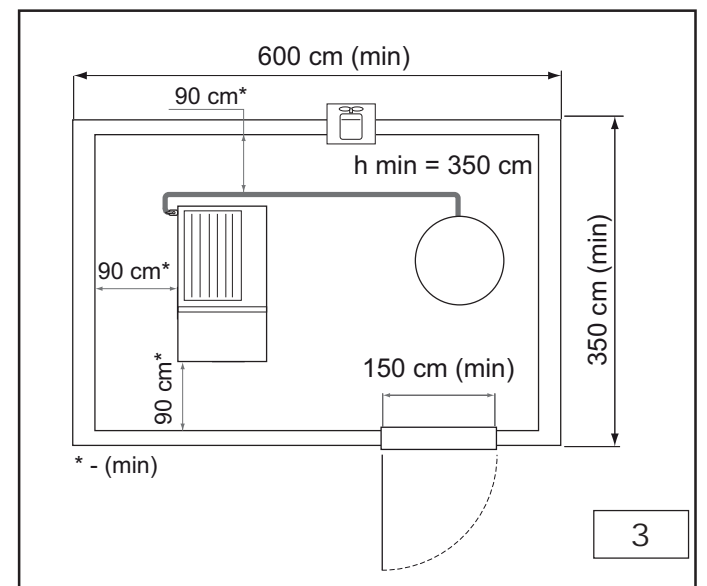
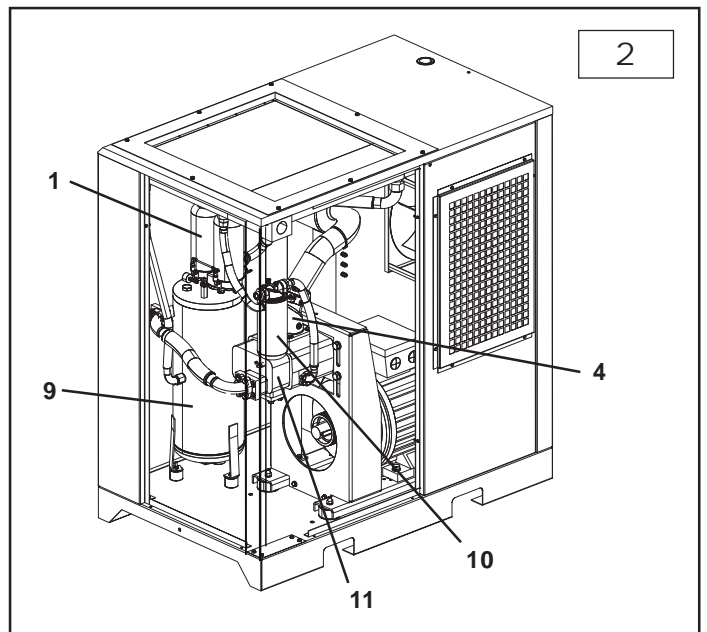
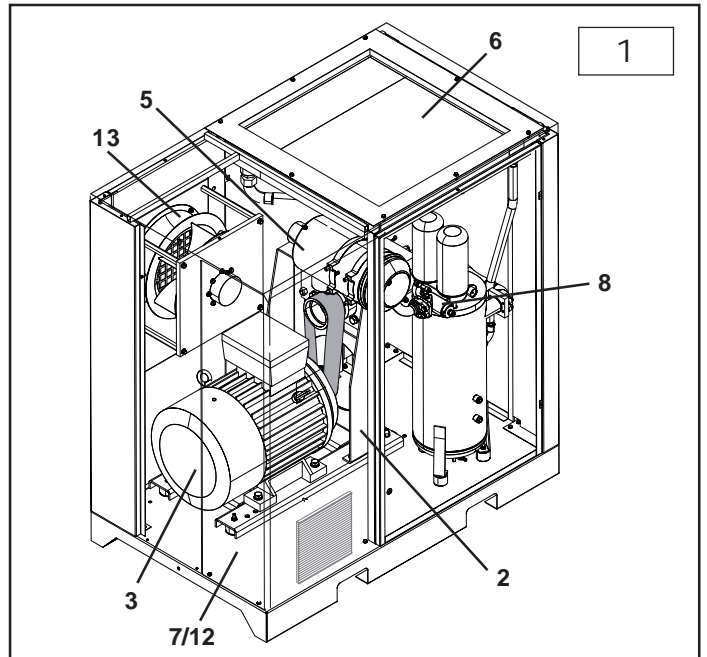

INSTALLATION

GB

INSTALLATION

- Position the machine at the final place of installation. Make sure it is stable and **leave at least 90 cm between the machine and the wall so as not to obstruct proper air flow to the fan.**

Position the air tank. Connect the compressor and tank using the supplied delivery hose.

Do not fit check valves between compressor and tank.



HOT AIR PIPING

- Hot air comes out from the upper side of the compressor at a temperature **15 ÷ 35°C** higher than the room temperature.
- If the room ventilation is not enough (door/window opening: under 2 sq. m), a pipe having at least the same cross-section as the radiator pipe is absolutely necessary. This pipe should be equipped with a valve conveying the hot air outside in summertime and inside in wintertime, thus using the compressor heat energy as auxiliary heating unit.

These pipes should not be longer than 4 m. Otherwise, an auxiliary fan should be installed on the outlet side.

ELECTRICAL HOOK-UP (fig. 3A)

- The mains cable should have a cross-section suitable for the machine power and should include **no. 3** phase wires, no. 1 neutral cable and **no. 1** earth wire.

- Between the mains cable and the compressor control panel a fused switch near the point where the cables go into the machine **is absolutely necessary**. The switch should be at least at 1.7 m from the ground.

- The switch (A) should be easily reached by the operator. The cables should be of the approved type and installed with the following grade of protection: minimum IP44

N.B. Follow the instructions in the table to select proper cable section. Sizing according to "VDE 0100, Part 430 and 523", star-delta starter, 30° C ambient temperature and cable length lower than 50 meters.

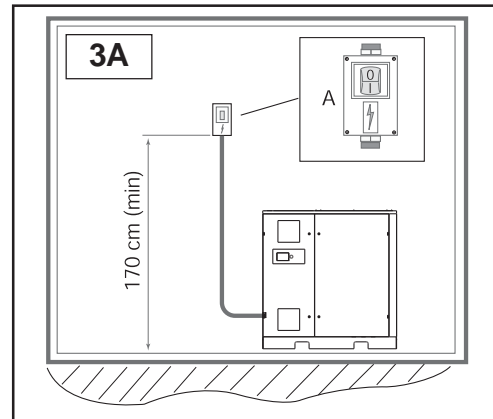

Electric connection	400 V		Giga SD 75 STC	Giga SD 100 STC
Conductor min. section	mm ²		4G50	4G70
Magnetic thermal switch	A		125	160
Fuses	AgI		125	160

CONTROLS AND SETTINGS

4

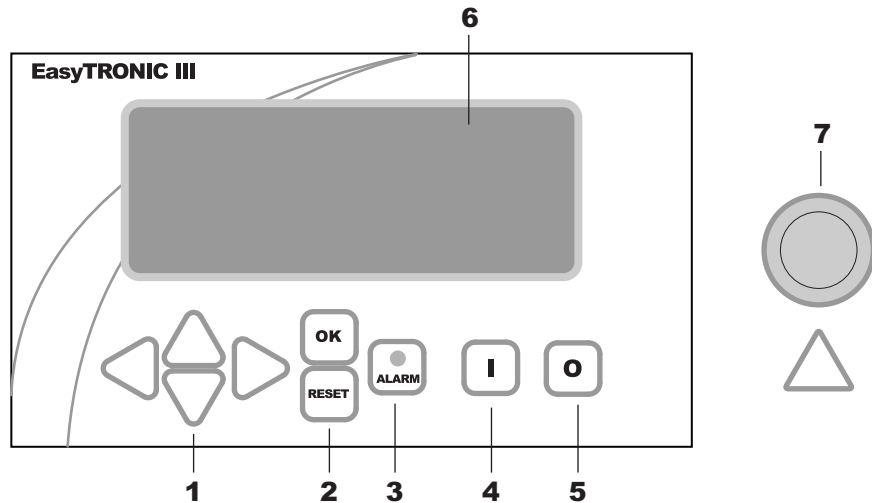

CONTROL PANEL

The main functions of the compressor are controlled by means of an electronic control unit installed in the control panel.

1. **Buttons for menu scrolling / modifying values**
2. **OK button** – for confirming settings
Reset button – for silencing alarms
3. **Alarm LED**
4. **I/ON Button** – switch-on
5. **O/ OFF Button** – switch-off.
6. **Display**

To adjust the contrast, press together (with machine in OFF status).

The contrast can be adjusted from 1 (darker) to 20 (lighter). Press OK to save the value.

7. **Emergency button** – to be used for stopping the compressor immediately only in the event of a real emergency.



TYPE OF SERVICE

Automatic operation

• In inverter-controlled operation, the compressor runs continuously based on a preset fixed pressure (factory setting) and automatically regulates motor rotation frequency to constantly meet the demand for compressed air. In other words, the compressor operates in such way to match air supply to actual plant requirement.

When there is no air demand, the compressor runs at the set minimum frequency.

Upon reaching “unloaded” pressure – which is calculated by the formula operating pressure + (start enable delta pressure/2) - the stop procedure begins, while message (STAND-BY) is displayed.

The compressor is started again at a pressure calculated by the formula: operating pressure - (start enable delta pressure/2).

MODIFIABLE PARAMETERS

Pressing the OK button with the machine OFF takes you to the menu of operating parameters. In certain cases a password is required in order to access the modifications. Use the buttons to scroll the menu.

0) Control unit ID (service password): selects the identification number of the control unit; if several compressors are connected to the same RS485 line, multiple IDs can be selected.

1) Maintenance – Pre-alarm hours (service password) : each working hour of the machine is counted down automatically; when the counter reaches 0, the control unit trips a Maintenance Alarm.

Use the XX buttons to scroll the items of the menu:

- | | |
|-------------------------|------------------------------------|
| 1. General maintenance: | hours remaining |
| 2. Air filter change: | hours remaining |
| 3. Oil filter change: | hours remaining |
| 4. Oil change: | hours remaining |
| 5. Bearing lubrication: | hours remaining |
| 6. Idle hours: | displays the hours of idle running |
| 7. Total working hours: | displays the total working hours |

The count preceded by the (-) sign indicates the number of hours that have elapsed since the last maintenance alarm.

The buttons can be used to set a new value (in this way overriding the previous alarm).

2) Alarm history (no password required): with this menu you can view the last 100 alarms.

3) Pre-alarm temperature (factory password): on this menu you can set the temperature differential (“delta”, expressed in °C) with respect to the maximum alarm temperature; the value can be set between 1 and 20.

Example: If the maximum temperature is 120°C and the differential value is 10°C, the maximum temperature pre-alarm is tripped at 110°C.

4) Maximum temperature (factory password): with this menu you can set the maximum temperature allowed; the setting range is from 0 to 150°C.

5) Minimum temperature (factory password): with this menu you can set the minimum temperature; the setting range is from 0 to -14°C.

6) Fan temperature (service password): with this menu you can adjust the temperature for activating the cooling fan; the setting range is from 0 to 150°C. At the preset temperature the fan starts; hysteresis is fixed at 10°C.

7) Duration of the idle running cycle (service password): with this menu you can change the duration of the machine idle cycle; the setting range is from 0 to 250 seconds.

8) Automatic start (service password): this parameter enables the automatic start; if it is activated, the compressor will restart automatically following an interruption of the electrical power supply.

9) Internal phase sequence (service password): this parameter enables the internal phase sequence control, or disables the internal control by activating the input without phases on the terminal block.

10) Language (no password required): this parameter allows you to change the language in which messages are displayed.

11) RS485 enable (no password required): this parameter is used to enable data transmission via RS485 and automatically disable transmission on RS232.

12) Set time and date (no password required): used for setting the current time and date.

13) PSI/BAR (no password required): for selecting the unit of measurement used to display the pressure.

14) Operating pressure set point (no password required): this parameter is used to set the pressure at which the compressor must shut down.

15) Operating differential set point (no password required): indicates the pressure at which the control unit enables compressor restart.

16) Maximum pressure (service password): this parameter sets the maximum pressure value that can be reached, i.e. the maximum value set in point 14.

17) Maximum pressure alarm (factory password): this parameter sets the maximum pressure value at which the control unit trips an alarm and blocks compressor operation.

18) Remote pressure (service password): when this parameter is enabled, the pressure and the related alarms continue to be displayed, but the compressor start is controlled by means of an external pressure switch contact.

19) Start programme (service password): this menu allows you to programme the starts and stops of the compressor. Use  to select one of the five programmes available and press OK to enter the desired data (start time, stop time, and day of the week).

To deactivate the programming, go to the menu and enter the same time of start and stop.

20) X1 progr. NC-NO (service password): allows you to invert the logic of the inputs of terminal block X1.

21) X7 progr. NC-NO (service password): allows you to invert the logic of the inputs of terminal block X7.

22) Motor therm. separate (service password): with the parameter ON, the thermal relays of the compressor and fan motors are separated on two different inputs.

23) Temp. unit of measurement (no password required): for selecting the unit of measurement of the temperature (°C-°F).

24) Maximum starts per hour (service password): for selecting the maximum number of restarts per hour allowed. If this value is exceeded, a signal is given.

25) Inverter (service password): inverter enable.

26) Minimum operation % (service password): minimum operation rate at which inverter must operate (max. rate is 100%).

27) Load delay (service password): this parameter is a time delay in seconds before load solenoid valve is energized to bring compressor from minimum to maximum frequency.

28) Inverter integration (service password): this parameter modifies the time constant of the integrative component of inverter rate calculation.

29) Inverter parameters (service password): allowed to only visualize inverter parameters.

1. max frequency
2. acceleration time
3. deceleration time
4. S-curve acceleration
5. rated frequency
6. boost at start
7. max tension
8. switch frequency
9. analogic control

CONTROLS AND SETTINGS

TABLE OF ADJUSTABLE PARAMETERS

	Parameter		min.	max.	Def.
0	ID		000	009	000
1	General maintenance:	hours	0	50000	4000
	Air filter change:	hours	0	50000	2000
	Oil filter change:	hours	0	50000	4000
	Oil change:	hours	0	50000	8000
	Bearing lubrication:	hours	0	50000	4000
	Idle hours:	hours	0	50000	0
	Total working hours:	hours	0	50000	0
3	Pre-alarm temperature	°C	0	20	5
4	Maximum temperature	°C	0	110	110
5	Minimum temperature	°C	-14	0	-7
6	Fan temperature	°C	0	150	80
7	Idle running cycle	sec.	0	250	180
8	Idle running cycle Stop	sec.	30	240	60
9	Automatic start				NO
10	Internal phase sequence				NO
11	Language				ITA
12	RS485 enable				YES
13	Time and date				
14	PSI/BAR	Bar			BAR
15	Idle	Bar	0	P.Max.	10
16	Load	Bar	0	2	0,5
17	Maximum pressure	Bar	0	P.all.-0,5	11
18	Maximum pressure alarm	Bar	0	16	14
19	Remote pressure	Bar			NO
20	Start programme				OFF
21	X01 progr. NC-NO				01010110
22	X07 progr. NC-NO				111111
23	Motor therm. separate				NO
24	Temp. unit				°C
25	Starts per hour	n°	1	200	10
26	Inverter				YES
27	Minimum operation %	%	0	100	50
28	Load delay	sec.	0	250	10
29	Inverter integration		001	250	001
30	Inverter parameters				
	Max.Frequence	Hz	0	400	0
	Accelerat. time	sec.	0	300	0
	Decelaration time	sec.	0	300	0
	Aceleration S-curve	sec.	0	5	0
	Rated frequence	Hz	0	400	0
	Start Boost	%	0	53,5	0
	Switch frequence	KHz			2
	Analogic control	mA			4-20

ALARM MESSAGES

When a fault occurs or the safety limits set are exceeded, the red alarm light comes on and the alarm in progress is shown on the display.

In the case of multiple alarms, use  to scroll through the items.

To silence an alarm, press the RESET button.

To delete all the non-active alarms, press RESET and hold it down for at least 2 seconds.

- **rot.dir.error**

Alarm tripped in the event of an incorrect phase sequence. The alarm blocks compressor operation; to restart operation, the correct phase sequence must be re-established.

N.B.: To completely reset the alarm you have to switch off the electrical power supply.

- **air.temp.sens. fault**

Alarm tripped in the event of a temperature sensor fault (sensor open or short circuit). The alarm blocks compressor operation; to restore operation, check the connection and/or replace the sensor, then press the RESET button XX.

- **screw.temp.sens. fault**

Alarm tripped in the event of a temperature sensor fault (sensor open or short circuit). The alarm blocks compressor operation; to restore operation, check the connection and/or replace the sensor, then press the RESET button XX.

- **max.oil.temp.**

Alarm tripped when the maximum oil temperature is reached. The alarm blocks compressor operation; to restore operation, wait for the temperature to fall below the programmed value, then press the RESET button XX.

- **min.oil.temp.**

Alarm tripped when the minimum oil temperature is reached. The alarm blocks compressor operation; to restore operation, wait for the temperature to rise above the programmed value, then press the RESET button XX.

- **oil.temp.pre-alarm**

Alarm tripped when the pre-alarm oil temperature is reached. The alarm does not block compressor operation. To silence the alarm, press the RESET button XX.

- **Motor thermal overload**

Alarm tripped when the motor PTC thermal relay + fan motor thermal relay is tripped. The alarm blocks compressor operation. To silence the alarm, first verify the cause and then press the RESET button XX.

- **Emergency button**

Alarm tripped when the emergency button is pressed, which blocks compressor operation. To silence the alarm, first reset the emergency button, then press the RESET button XX.

- **Maintenance**

This alarm signals the user that the machine is due for routine maintenance (oil change, filters, etc.).

The alarm must be silenced by the service technician who performs the maintenance, as described in the section "Modifiable Parameters".

- **max.press.alarm**

Alarm tripped when the maximum pressure set is exceeded. The alarm blocks compressor operation.

To silence the alarm, first restore the correct pressure, then press the RESET button XX.

- **press.sens.fault**

Alarm tripped when the pressure sensor connected to the 4-20mA input is not working correctly. The alarm blocks compressor operation.

To silence the alarm, first restore the normal status of the pressure sensor, then press the RESET button XX.

- **comm.error**

Alarm tripped when communication between the control unit and the display is interrupted. The alarm blocks compressor operation. Check the connections and press RESET XX.

- **screw.motor.therm.** (only if parameter 22 is activated)

Alarm tripped in the event that the screw motor thermal relay is tripped. The alarm blocks compressor operation.

To silence the alarm, first verify the cause, then press the RESET button XX.

- **fan.motor.therm.** (only if parameter 22 is activated)

Alarm tripped in the event that the fan motor thermal relay is tripped. The alarm blocks compressor operation.

To silence the alarm, first verify the cause, then press the RESET button XX.

- **Max.starts.hour**

Indicates that the number of starts per hour is greater than the value set. The alarm does not block compressor operation.

If this alarm is tripped frequently, check and if necessary increase the idle running time.

- **Inverter error**

The alarm blocks compressor operation. Press the key RESET to silence the alarm. If problem persists, contact a service center without delay.

START-UP PROCEDURE AND DISPLAY INFORMATION

FIRST START-UP

Before starting the machine for the first time, **make sure that:**

- the power supply voltage corresponds to the voltage indicated on the CE plate
- the electrical connections have been made using adequately sized cables
- the master switch (on the wall) has suitable fuses
- the oil level is higher than the minimum (where necessary, fill using oil of the same type)
- the air outlet cock is completely open.

The first start-up of the compressor must only be carried out by a specialised technician.

Press the  button:

If the machine does not start and the message “rot.dir.error” appears on the display:

switch off the electrical power using the wall switch, open the electrical cabinet door and invert the position of two phases in the terminal block, close the door, restore voltage and restart the machine.

If the machine starts on the first try:

display status at start-up (remains for 5 seconds)

software
release

```
Easy Tronic III
V. 0. 0. 0 dd/mm/yy
Easy Tronic III
```

date

display status during normal operation

```
--screw. temp: 065° C
06. 5Bar 000% 000%
STATUS=OFF
time. .... date. ....
```

Line 1

Default display “—screw.temp.” = temperature of the screw.

Using   you can view the following information:

Inside temp.	indicates the temperature inside the electrical compartment
—air.temp.	indicates the temperature of the air at outlet
—total hours	indicates the total working hours
—load hours	indicates the working hours with load
—idle hours	indicates the idle running hours
maint.hours	indicates the hours remaining until maintenance is required
air filter h.	indicates the hours remaining until air filter replacement is required
bearing.lubric.	indicates the hours remaining until lubrication of the bearings is required
oil filter h.	indicates the hours remaining until oil filter replacement is required
starts/hour	indicates the number of starts recorded in the last hour

After 25 seconds without any buttons being pressed, the default display returns.

Line 2

Indicates the pressure inside the screw compressor.

Indicates the inverter pilotage value.

Indicates the inverter operation rate.

Line 3

Compressor status:

IDLE	idle running
LOAD	the compressor is loading
STAND-BY	waiting for start command
REMOTE-OFF	waiting for remote start command
OFF	the compressor is powered but not operating

Line 4

DATE AND TIME if a start-up has been programmed, a blinking clock appears in the lower right-hand corner.

START/STOP CYCLE

- Pressing the  button

Stand-by: a (STAND-BY) message is displayed. If the compressor had been switched off, it will take 15 seconds before cycle starts; otherwise the compressor remains in the stand-by mode until the pressure switch signals a demand for compressed air.

Starting: the compressor “ramps up” to 50% of set maximum frequency and the message (UNLOADED) is displayed

Full-load starting: when the set “load delay” time times out, the compressor reaches maximum frequency and the message (LOADED) is displayed.

- Pressing the  button

The load solenoid valve is disabled, the unload cycle is started and a flashing (UNLOADED) message is displayed (during this time, the compressor operates at the set minimum frequency). When the unload cycle is over, the compressor shuts down and the message “OFF” is displayed.

TECHNICAL DIAGRAM

- A**
Motor
- B**
Compressor
- C**
Suction regulator
- D**
Oil separator tank
- VO**
Fast exhaust valve
- S(NG)**
Solenoid valve N.C
- DS**
Pressure transducer
- MAX**
Selector valve
- PR MIN**
Min. pressure switch
- PR MAX**
Max. pressure switch
- MPVL**
Min. pressure valve

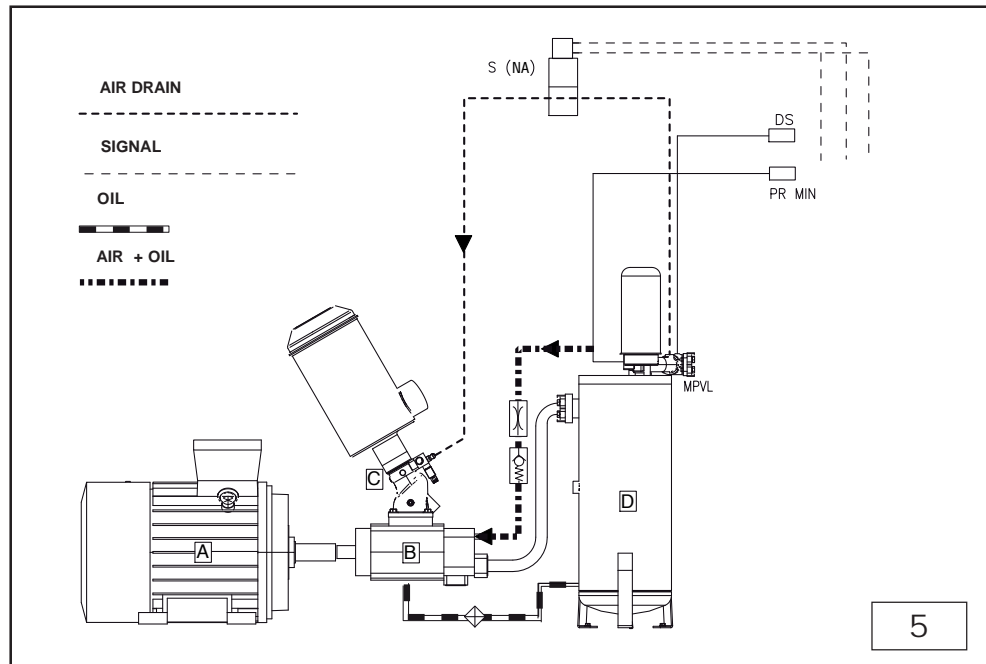

OPERATING MODE

- At the end of the starting cycle, the compressor reaches maximum operating speed and starts to compress air in the tank (5).
- When close to reaching desired operating pressure, the compressor begins to vary motor rotation frequency (max.100%, min. 50%) so as to keep air delivery steady depending on operating pressure.
- Compressed air escapes through the min. pressure valve (7), when pressure of oil separator tank is higher than 4 bar.
- Compressed air compresses oil inside tank (5) and causes it to flow through tube (8) to the radiator (9).
- Cooled oil is returned to filter (11) through tube (10).
- From filter (11), oil reaches compressor (3) through tube (12). Oil is mixed with sucked air to form an air/oil mixture that provides sealing and lubrication of compressor moving parts.
- The air/oil mixture goes back to tank (5), where air and oil are first separated by centrifugation and then by the oil separator filter (6).
- As a result, tank (5) will deliver air only to air radiator (9) through tube (13). Air is then conveyed to mains through a cut-off cock.
- Min. pressure valve (7) serves also as a check valve.
- Compressor delivers compressed air to outer air tank.
- Tank inner pressure increases until reaching max. calibration value.
- Once max. value is reached, pressure gauge starts timer and powers off solenoid valve of regulator (2).
- Regulator (2) closes and compressor stops compressing and starts idling.
- Timer continues counting until reaching set value and, if pressure is unchanged, stops the electric motor. If pressure drops to minimum value set on controller, solenoid valve is powered and opens before timer counting is over.
- Regulator (2) opens and compressor operates under normal load; timer is reset.
- This cycle is automatically repeated.

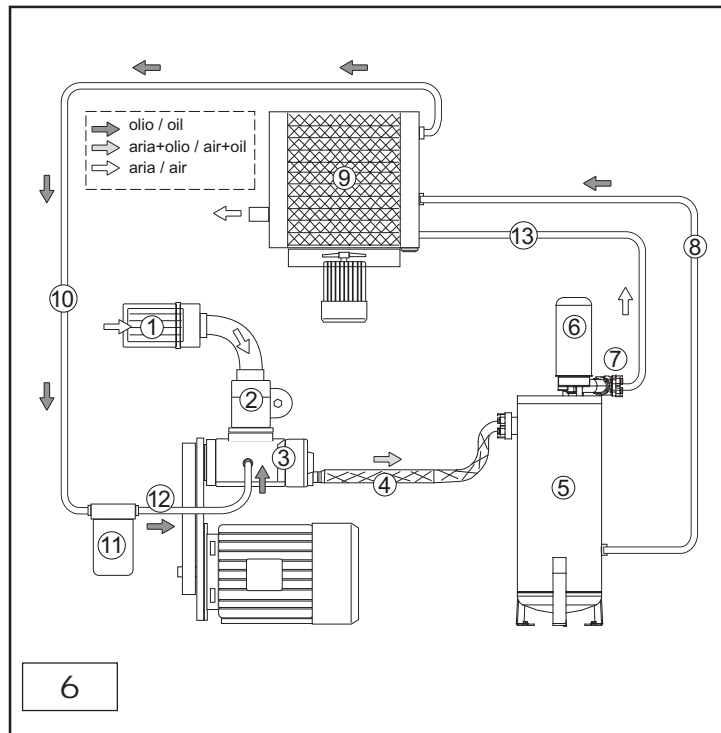

OPERATION



CAUTION! Before carrying out any maintenance operation:

- Activate automatic motor stop.
- Turn off the external wall-mounted switch (**do not use the emergency button**).
- Close line cock.
- Make sure that no air is present inside the oil separator tank.
- Wait at least 3 min. for the radial fan to stop.

Legend to to figure 7

- A)** right side panel (oil filter – intake)
- B)** rear door (oil filter - belt - pulleys)
- C)** rear panel (fan - prefilter)
- D)** left side panel (motor)
- E)** front door (electrical compartment)
- F)** front door (oil separator air filter)

AFTER THE FIRST 100 OPERATING HOURS

- Check **oil level** and top-up with same oil, if needed
- Check **screw tightening**: pay special attention to power electric contact screws.
- Visually check **sealing of all connectors**.
- Check **drive belt tension** and tension up, if needed
- Check **operating hours** and **type of duty cycle** chosen
- Check **room temperature**.
- Change **oil filter**.

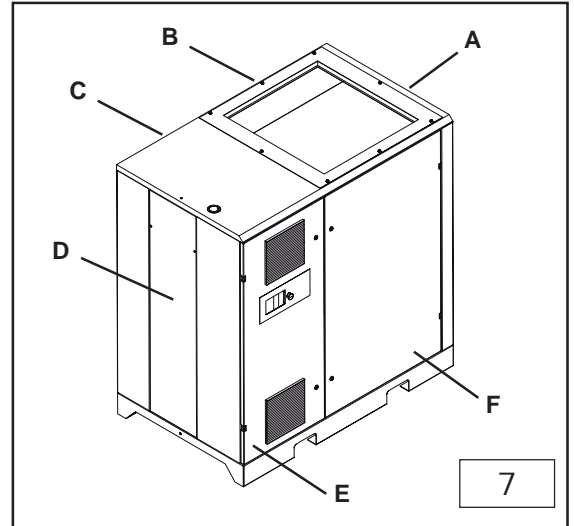

EVERY 500 OPERATING HOURS

Carefully clean AIR FILTER (fig. 8)

- Open the door **F** using the provided key
- Open door **B** with supplied key.
- Manually undo the knob (1) and remove filter cover.
- Manually undo the knob (2) and remove filtering element.
- Clean filtering element (3) with compressed air from the inside to the outside. Check against the light for possible cuts: replace element, if any.

Carefully clean AIR PREFILTER (fig. 8)

- Remove prefilter (4).
- Wash with water and soapy solution. Fully dry before refitting the prefilter and then restart the compressor.

Check oil level (fig.9)

- Open door **F** with supplied key.
- Bleed air off the tank through the cock (1).
- Check the oil level on lights 5 and 7. If the level is below or barely visible from the lower light, top it up, using the same type of oil.

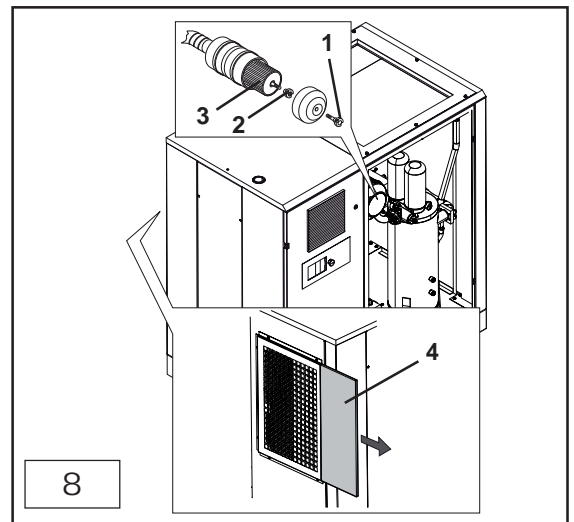

EVERY 2000 HOURS

DRIVE BELT tension (fig.12)

To perform this check you need a special measurement instrument that provides a precise indication of the level of tension of the belt by means of a frequency measurement.

Proceed as follows:

- Open the door (**B**) (see fig.7).
- Bring the microphone of the measurement instrument up to the belt at the point indicated with "test" (about halfway) and strike the belt with a spanner.
- Read the value detected by the instrument and if it is different from the values indicated on the table, adjust the tension:

Higher value = belt too tight

Lower value = belt too loose

- Loosen screws **A** to allow the attachment plate on which the screw unit is fixed to slide, and use adjusting nut **B** to adjust the tension.

Turn the nut clockwise to increase tension and anti-clockwise to reduce tension.

Re-tighten screws **A** and check the frequency value; if necessary, repeat the operation until the desired value has been reached.

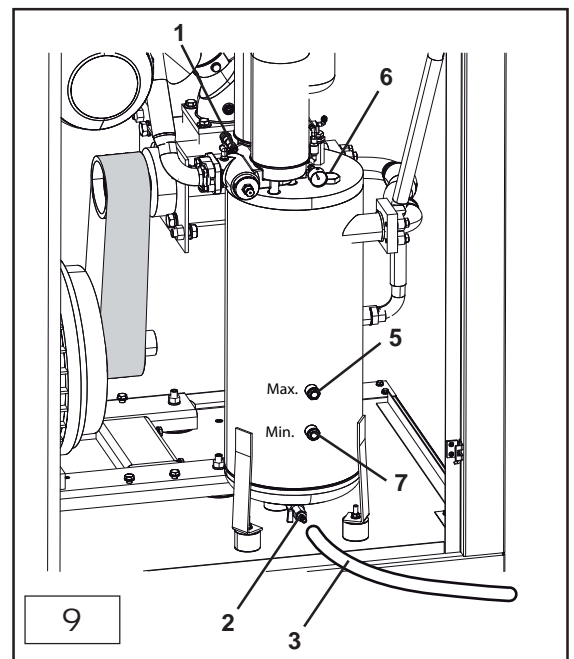

EVERY 4000 HOURS

Grease the bearings of the electric motor by means of the appropriate grease nipples. Open panel D and door B and use the 5-mm hex key.

Follow the instructions on the electric motor manual. Required grease quantity: 20g.

Use soapy lithium grease.

Replace the air prefilter.

EVERY 8000 HOURS

Change OIL (fig.9)

- Open door F with supplied key.
- Bleed air off the tank through cock (1).
- Connect drain tube (3) to cock (2).
- Unscrew the filling cap (6), open the tap (2) and let the oil flow out completely.
- Close the tap (2) and remove the tube (3) before pouring new oil (complete filling amount: 36 lt.).
- Start the machine and let it run for 5 minutes.
- Allow some minutes and then bleed off all air. Check oil level and top up, if necessary.

NEVER MIX DIFFERENT TYPES OF OIL TOGETHER, OTHERWISE COMPRESSOR MIGHT DAMAGE. Refer to the table for oil selection.

AFTER THE FIRST 2,000 OPERATING HOURS AND THEN EVERY 4,000 OPERATING HOURS

Change OIL FILTER (fig.10)

- Change the filter **at any oil change** with the oil separator tank **not** under pressure. Always bleed all air off the cock (1) (see fig. 11).
- Open door (A) (see fig.7). The oil filter is inside the middle stand, as shown in the figure.
- Undo the filter with the proper tool. Replace with a new filter. Always apply a film of oil on filter edge and gasket before tightening.

Change OIL SEPARATOR FILTER (fig.11)

- Open door (F) (see fig.7) and bleed all air off the tank through cock (1).
- Unscrew the two filters (7 and 8) (fig.11) and replace them with two new ones. Spread a light layer of oil on the gasket before mounting it.

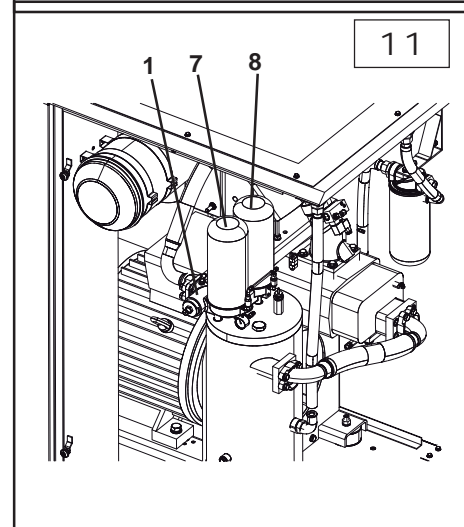
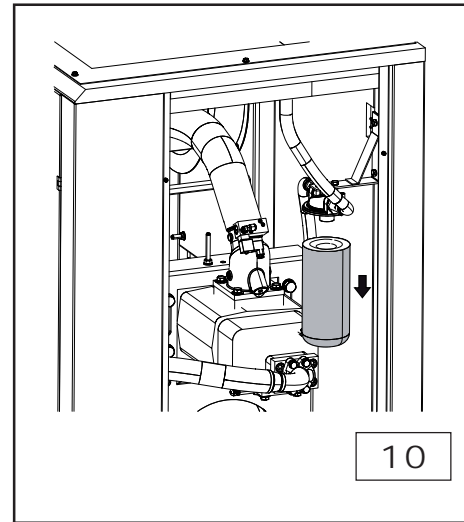

EVERY 16000 HOURS

Replace the DRIVE BELT (fig.12)

Proceed as follows:

- Open the door (B) (see fig.7) and remove the protective panel of the belt/pulley compartment.
- Loosen screws **A** to allow the attachment plate on which the screw unit is fixed to slide.
- Loosen nut **B** until the belt is completely relaxed and remove it.
- Fit the new belt **C** and tighten it as described in the

previous section.

Also replace

- Compressor seal ring
- Tank safety valve

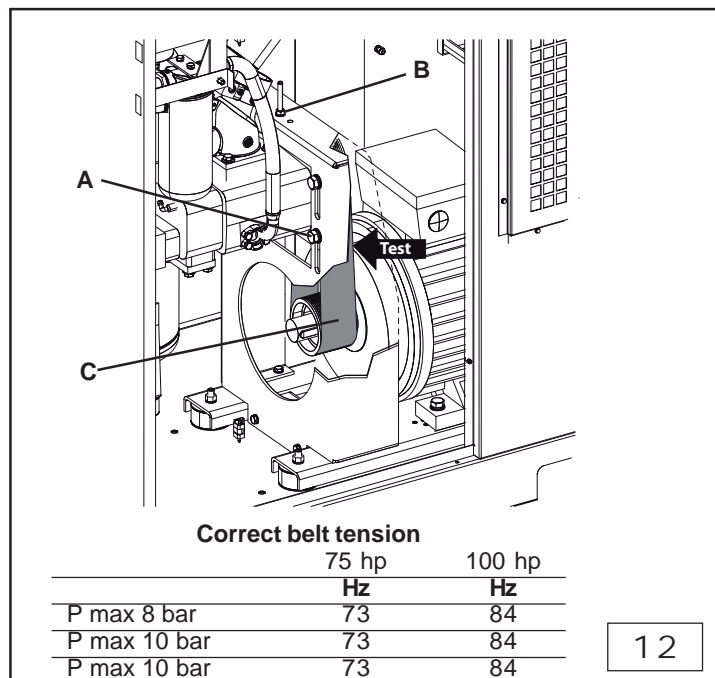

MAINTENANCE



EVERY 8,000 OPERATING HOURS

MIN. PRESSURE valve (fig.13)

Replace gaskets (2) and (3)

Replacing the drain unidirectional valve

- Open door (F) (see fig.7) and bleed all air off the tank through the cock (1) (fig. 11).
- Unscrew the unidirectional valve (1) and replace it by restoring the hydraulic connections.

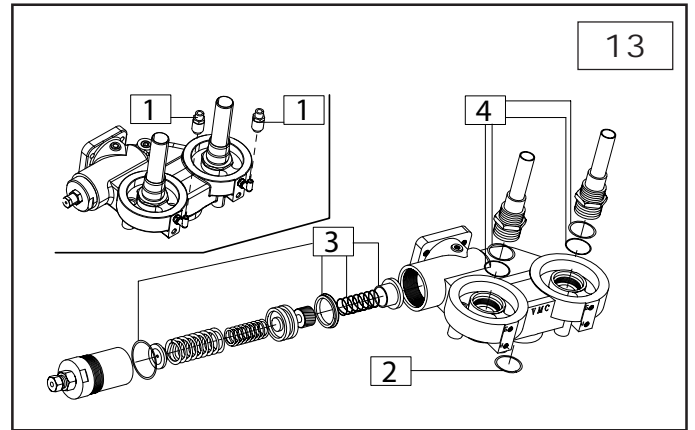

CLEANING THE RADIATOR

Open the front panel of the compressor cabin and position a sheet of protective plastic underneath the radiator pack;

- Spray (with washing gun + solvent) from the outside towards the inside;
- Control the perfect passage of the air through the radiator.

SERVICE TABLE - WARNING

Oil is an essential factor. When using an oil type which is different from the recommended one - RotEnergy Plus - some service intervals must be changed. Please refer to table.

In any case, a different oil MUST be used ONLY when oil is fully changed. NEVER MIX DIFFERENT TYPES OF OIL TOGETHER. Never top up with a different type of oil.

EXHAUSTED OIL IS HIGHLY POLLUTANT! Dispose of exhausted oil in compliance with current laws.

Type of maintenance	Maintenance schedule		
	Work hours	O	At least
<i>ORDINARY MAINTENANCE</i>			
Condensation release	-		Twice per month
Cleaning the radiator			Once per year
Oil level check and refill	500		
Clean the air prefilter	500		
Clean the air filter	500		
Check for clogging and clean the radiator	1000		
Check the transmission belt	2000		
Greasing the electric motor bearings	4000		
Air filter substitution	2000		Once per year
Oil filter substitution	4000		Once per year
Discharge oil filter substitution	4000		Once per year
Air prefilter substitution	4000		Once per year
Total oil change	8000		Once per year
<i>EXTRAORDINARY MAINTENANCE</i>			
One-way draining valve substitution	4000		Once per year
Suction valve overhaul	12000		-
Thermostatic valve overhaul	12000		-
Minimum pressure valve overhaul	12000		-
Solenoid-valve substitution	12000		-
Substitute the flexible tube	12000		-
Substitute the transmission belt	12000		-
Substitute the electric motor bearings	24000		-
Screw compressor overhaul	24000		-

TROUBLE-SHOOTING



When a fault occurs or the safety limits set are exceeded, the red alarm light comes on and the alarm in progress is shown on the display.

In the case of multiple alarms, use to scroll through the items.

To silence an alarm, press the RESET button.

Fault/Alarm message	Cause	Solution
rot.dir.error	Power supply phases inverted	Open the electrical cabinet and invert the phases.
screw.temp.sensor fault	Fault of the temperature sensor	Replace the screw temperature sensor
max.oil.temp.	Radiator clogged	Clean the radiator
	Low oil level	Fill the oil
	Oil mist separator filter clogged	Replace the filter
	Air pre- filter clogged	Clean the filter
	Fan not working	Check connections
min.oil.temp.	Low room temperature	Heat the room. Wait
Motor thermal overload	Low line voltage	Check the voltage.
	Motor temperature overload	Check the operation of the cooling fan; if necessary activate it in "manual" or with the switch inside the electrical compartment.
	High room temperature	Increase the ventilation in the room. Wait
max.press.alarm	The intake regulator did not close at the end of the cycle.	Check that current to the solenoid valve is switched off and that the shutter opens normally. If necessary, remove and clean the intake regulator.
	Oil mist separator filter clogged.	Replace the oil mist separator filter.
	Line cock closed.	Open the cock.
	Minimum pressure valve blocked.	Check and clean the valve, if necessary replace the gaskets.
press.sensor fault	The pressure sensor is faulty.	Replace the pressure sensor.
High oil consumption	Defective draining	Check the drain hose.
	Oil level too high	Check the oil level and if necessary remove some.
	Oil mist separator filter faulty	Replace the oil mist separator filter.
	Poor seal of the oil mist separator filter gaskets	Replace the gaskets.
Oil leakage from the intake filter	The intake regulator does not close	Check the intake regulator and the solenoid valve.
The compressor performs poorly	Belt loose	Tighten the belt.
The compressor does not compress air	The intake regulator is closed and does not open because it is soiled.	Remove the filter and check the opening; if necessary disassemble and clean it.
	The intake regulator is closed and does not open due to lack of control.	Check the operation of the solenoid valve; replace if necessary.
The compressor does not restart	The minimum pressure valve does not close perfectly.	Disassemble the valve and clean it; if necessary replace the gaskets.
Difficult start-up	Low line voltage	Check the mains voltage.
	Cold room	Heat the room.
Oil in the cabin	Leakage from hoses	Tighten the unions.

TECHNICAL FEATURES

Technical features		Giga SD 75 STC			Giga SD 100 STC		
Pressure	bar g	7,5	10	13	7,5	10	13
Compressor type	type	END 25			END 25		
Air volume supplied (ISO 1217 annex C)	l/min	9300/4600	8300/4100	7000/3400	12200/6000	10500/5100	8300/4000
Oil quantity	l	36			36		
Oil quantity for topping-up	l	7			7		
Max. final over temperature	°C	11			15		
Removed heat	kJ/h	188000			276000		
Fan flow rate	m3/h	7800			10000		
Oil residues in the air	mg/m3	2-4			2-4		
Electric motor	type	250 B3			280 B3		
Motor power	kW	55			75		
Max. power absorbed	kW	60			78		
Electrical box protection class	IP	44			44		
Max. Start-up per hour	n°	10			10		
Ambient limit temperature	°C	+2/+45			+2/+45		
Noise level (Pneurop/Cagi PN2CPTC2)	dB(A)	70			72		

Electrical data		Giga SD 75 STC		Giga SD 100 STC	
Voltage	V/Hz	400-3/50		400-3/50	
Auxiliary voltage	V/Hz	24/50		24/50	
Start-up Absorbed current	Amp	135		175	
Max. Absorbed current	Amp	97		133	
Max. Absorbed current (vacuum)	kW	15,5		18	
Electrical motor protection class	IP	55		55	
Motor insulation class		F		F	
Service factor		1,1		1,1	

Protection devices		Giga SD 75 STC		Giga SD 100 STC	
Max oil temperature	°C	110		110	
Pre-alarm Oil temperature	°C	105		105	
Motor thermal relay setting	Amp	PTC		PTC	
Safety valve setting	bar	14		14	

Dimensions		Giga SD 75 STC		Giga SD 100 STC	
Length	mm	1800		1800	
Width	mm	1090		1090	
Height	mm	1860		1860	
Weight	kg	1725		1795	
Air fitting	Rp	2"		2"	

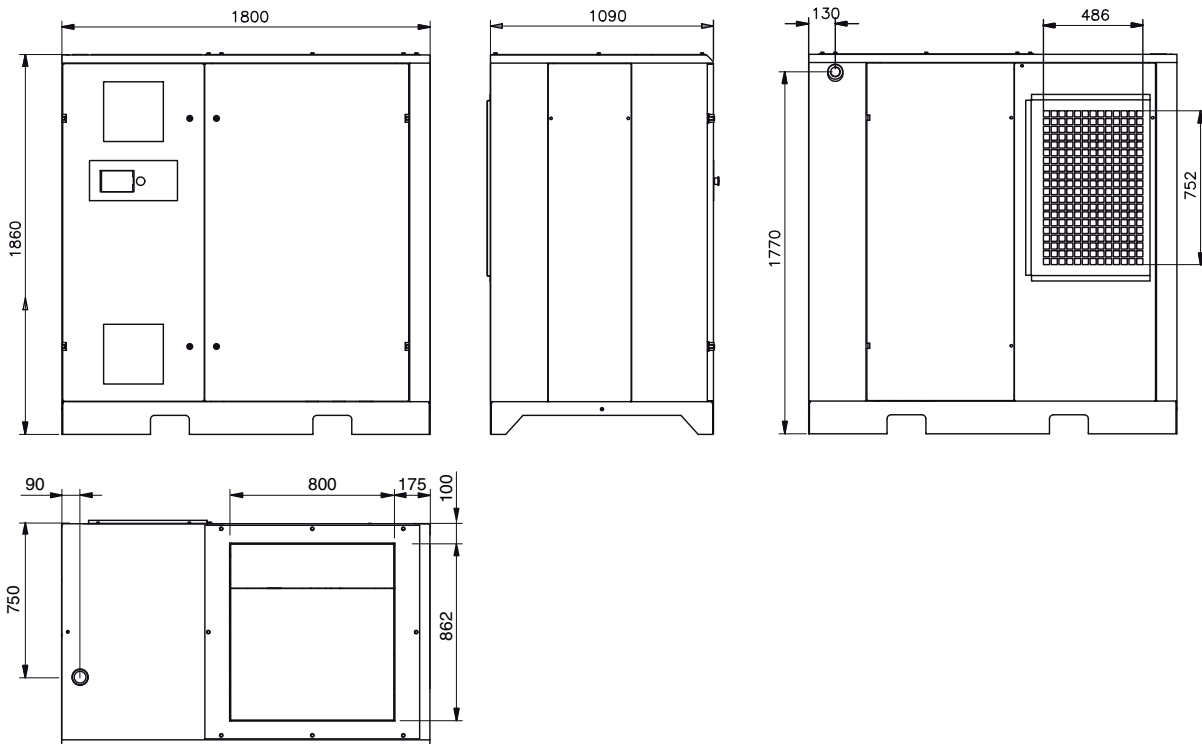

WIRING DIAGRAM

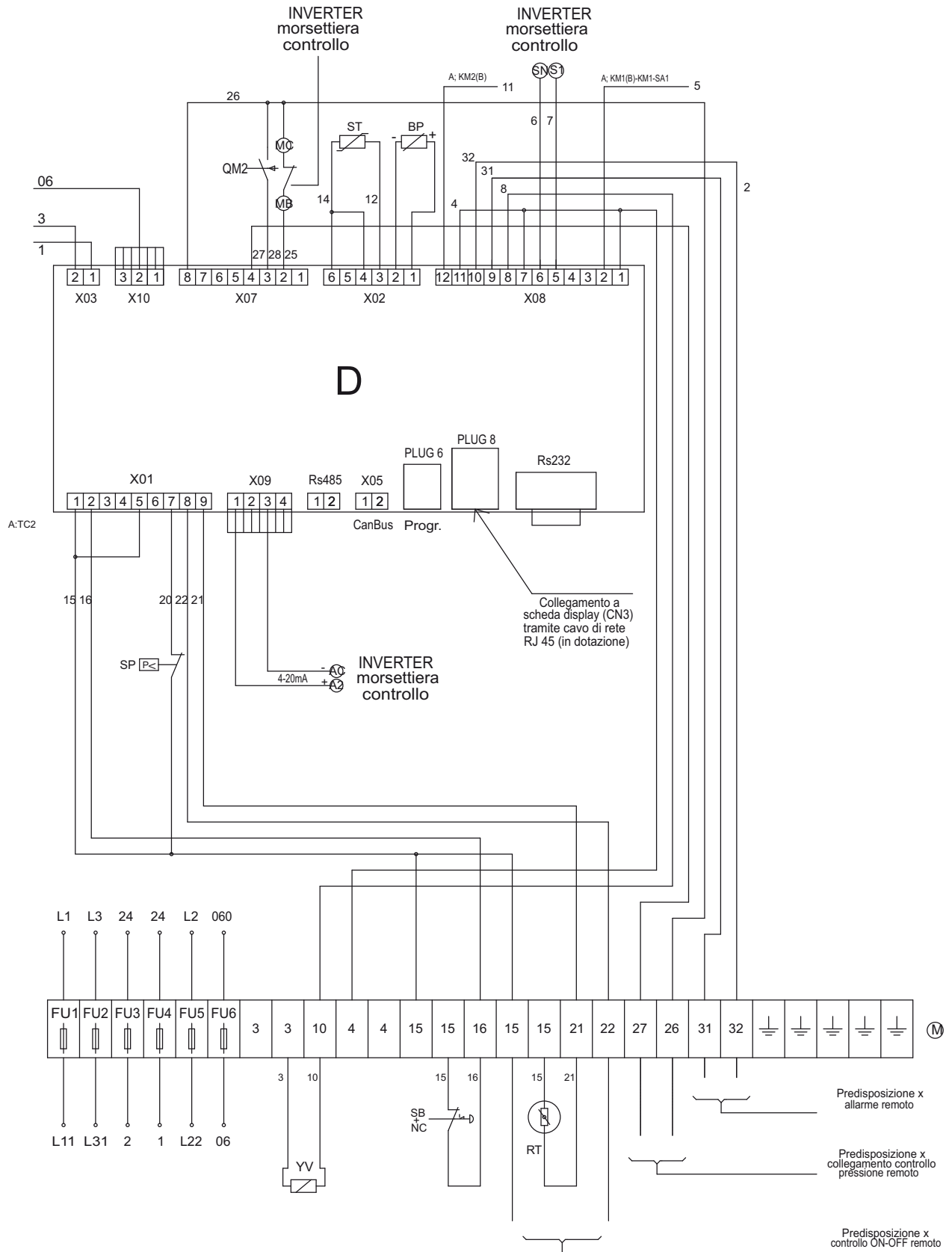

WIRING DIAGRAM

GB

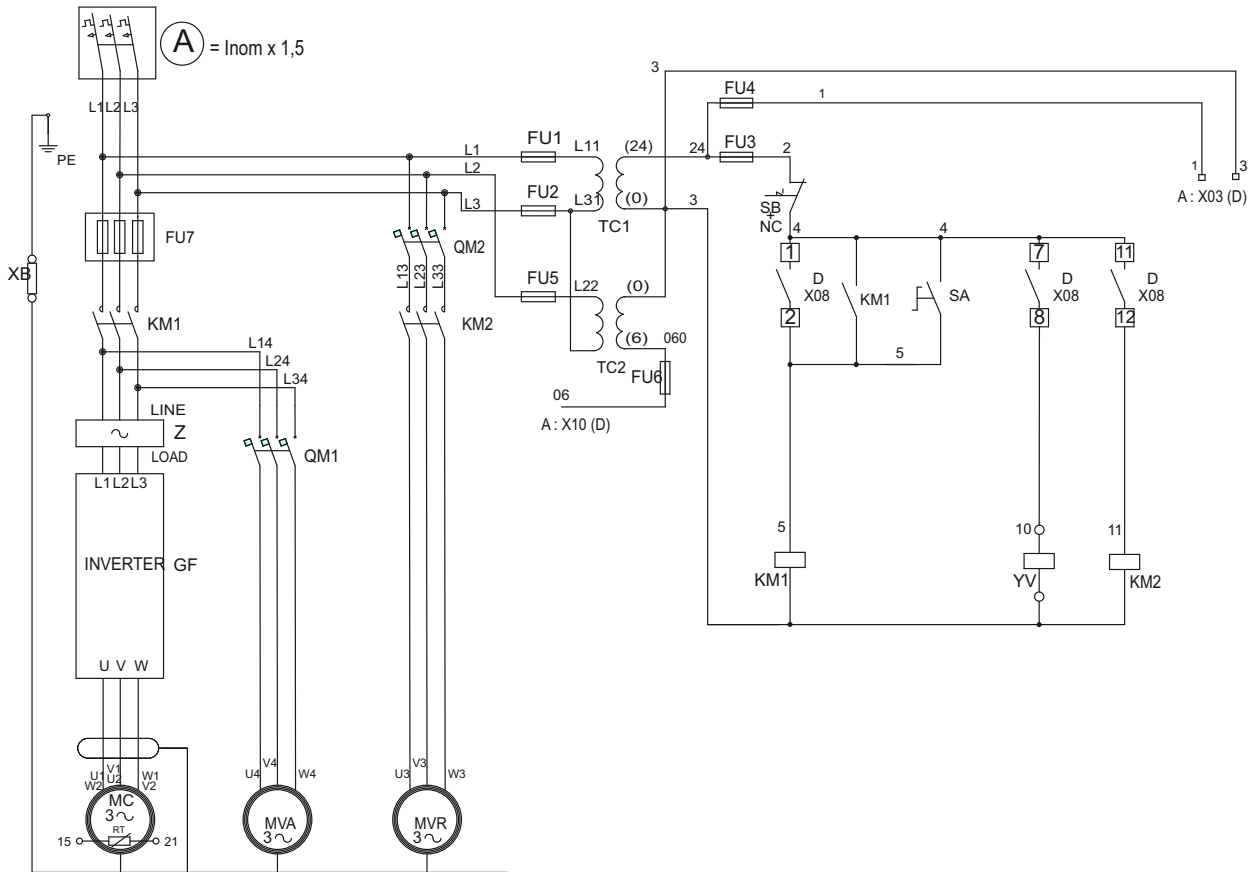

		75 STC	100 STC
FU7	N.1 Three-phase fuses holder base	NH00-160 A	NH1-200 A
FU1-FU2	Ceramic fuses 6.3x32 4A 500V		
FU4-FU5	Ceramic fuses 6.3x32 1A 500V		
FU3	Ceramic fuses 6.3 x 32 8 A 500V		
FU6	Ceramic fuses 6.3 x 32 500mA 500V		
GF	Inverter	55 KW	75 KW
Z	Three-phase filter 3 x 170 A		
KM1	Compressor motor-inverter line contactor 24V 50/60HZ	92 KW (**)	181 KW (**)
KM2	Radiator fan-motor contactor 24V 50/60Hz	4 kW *	4 kW *
QM1	Inlet fan-motor protection switch	$(0,22-0,32)/(0,28-0,4)$	$(0,22-0,32)/(0,28-0,4)$
QM2	Radiator fan-motor protection switch	(1,8-2,5)	(2,2-3,2)
RT	Compressor motor thermistors		
TC1	Transformer Pr. 230-400 V Sec.24V	220 VA	220 VA
TC2	Transformer Pr.400 V Sec.0-6 V		
SA	Inverter setting selector		
SB	Emergency button + 2 NC 230V 10A		
SP	Min. pressure - pressure switch 1NC 250VAC		
BP	Line pressure transducer 4-20 mA 0-16 bar		
ST	Screw delivery temperature probe TD4A		
D	Electronic controller Easy-tronic III		
YV	Solenoid valve 24VAC 50/60 Hz		
●	Terminal board		
MC	Compressor motor	55 kW	75 kW
MVR	Radiator fan motor		
MVA	Inlet fan motor	148/205 W	148/205 W
	Compressor motor cable cross-section (sq. mm)	3x50 + 1x25GV	3x70 + 1x35GV
	Radiator motor cable cross-section (sq. mm)	4G1.5	4G1.5